



USER'S GUIDE

RF Test Guidance for Apollo Based Equipment

Ultra-Low Power Apollo SoC Family

A-SOCAPG-UGGA01EN v2.1



Legal Information and Disclaimers

AMBIQ MICRO INTENDS FOR THE CONTENT CONTAINED IN THE DOCUMENT TO BE ACCURATE AND RELIABLE. THIS CONTENT MAY, HOWEVER, CONTAIN TECHNICAL INACCURACIES, TYPOGRAPHICAL ERRORS OR OTHER MISTAKES. AMBIQ MICRO MAY MAKE CORRECTIONS OR OTHER CHANGES TO THIS CONTENT AT ANY TIME. AMBIQ MICRO AND ITS SUPPLIERS RESERVE THE RIGHT TO MAKE CORRECTIONS, MODIFICATIONS, ENHANCEMENTS, IMPROVEMENTS AND OTHER CHANGES TO ITS PRODUCTS, PROGRAMS AND SERVICES AT ANY TIME OR TO DISCONTINUE ANY PRODUCTS, PROGRAMS, OR SERVICES WITHOUT NOTICE.

THE CONTENT IN THIS DOCUMENT IS PROVIDED "AS IS". AMBIQ MICRO AND ITS RESPECTIVE SUPPLIERS MAKE NO REPRESENTATIONS ABOUT THE SUITABILITY OF THIS CONTENT FOR ANY PURPOSE AND DISCLAIM ALL WARRANTIES AND CONDITIONS WITH REGARD TO THIS CONTENT, INCLUDING BUT NOT LIMITED TO, ALL IMPLIED WARRANTIES AND CONDITIONS OF MERCHANTABILITY, FITNESS FOR A PARTICULAR PURPOSE, TITLE AND NON-INFRINGEMENT OF ANY THIRD PARTY INTELLECTUAL PROPERTY RIGHT.

AMBIQ MICRO DOES NOT WARRANT OR REPRESENT THAT ANY LICENSE, EITHER EXPRESS OR IMPLIED, IS GRANTED UNDER ANY PATENT RIGHT, COPYRIGHT, MASK WORK RIGHT, OR OTHER INTELLECTUAL PROPERTY RIGHT OF AMBIQ MICRO COVERING OR RELATING TO THIS CONTENT OR ANY COMBINATION, MACHINE, OR PROCESS TO WHICH THIS CONTENT RELATE OR WITH WHICH THIS CONTENT MAY BE USED.

USE OF THE INFORMATION IN THIS DOCUMENT MAY REQUIRE A LICENSE FROM A THIRD PARTY UNDER THE PATENTS OR OTHER INTELLECTUAL PROPERTY OF THAT THIRD PARTY, OR A LICENSE FROM AMBIQ MICRO UNDER THE PATENTS OR OTHER INTELLECTUAL PROPERTY OF AMBIQ MICRO.

INFORMATION IN THIS DOCUMENT IS PROVIDED SOLELY TO ENABLE SYSTEM AND SOFTWARE IMPLEMENTERS TO USE AMBIQ MICRO PRODUCTS. THERE ARE NO EXPRESS OR IMPLIED COPYRIGHT LICENSES GRANTED HEREUNDER TO DESIGN OR FABRICATE ANY INTEGRATED CIRCUITS OR INTEGRATED CIRCUITS BASED ON THE INFORMATION IN THIS DOCUMENT. AMBIQ MICRO RESERVES THE RIGHT TO MAKE CHANGES WITHOUT FURTHER NOTICE TO ANY PRODUCTS HEREIN. AMBIQ MICRO MAKES NO WARRANTY, REPRESENTATION OR GUARANTEE REGARDING THE SUITABILITY OF ITS PRODUCTS FOR ANY PARTICULAR PURPOSE, NOR DOES AMBIQ MICRO ASSUME ANY LIABILITY ARISING OUT OF THE APPLICATION OR USE OF ANY PRODUCT OR CIRCUIT, AND SPECIFICALLY DISCLAIMS ANY AND ALL LIABILITY, INCLUDING WITHOUT LIMITATION CONSEQUENTIAL OR INCIDENTAL DAMAGES. "TYPICAL" PARAMETERS WHICH MAY BE PROVIDED IN AMBIQ MICRO DATA SHEETS AND/OR SPECIFICATIONS CAN AND DO VARY IN DIFFERENT APPLICATIONS AND ACTUAL PERFORMANCE MAY VARY OVER TIME. ALL OPERATING PARAMETERS, INCLUDING "TYPICALS" MUST BE VALIDATED FOR EACH CUSTOMER APPLICATION BY CUSTOMER'S TECHNICAL EXPERTS. AMBIQ MICRO DOES NOT CONVEY ANY LICENSE UNDER NEITHER ITS PATENT RIGHTS NOR THE RIGHTS OF OTHERS. AMBIQ MICRO PRODUCTS ARE NOT DESIGNED, INTENDED, OR AUTHORIZED FOR USE AS COMPONENTS IN SYSTEMS INTENDED FOR SURGICAL IMPLANT INTO THE BODY, OR OTHER APPLICATIONS INTENDED TO SUPPORT OR SUSTAIN LIFE, OR FOR ANY OTHER APPLICATION IN WHICH THE FAILURE OF THE AMBIQ MICRO PRODUCT COULD CREATE A SITUATION WHERE PERSONAL INJURY OR DEATH MAY OCCUR. SHOULD BUYER PURCHASE OR USE AMBIQ MICRO PRODUCTS FOR ANY SUCH UNINTENDED OR UNAUTHORIZED APPLICATION, BUYER SHALL INDEMNIFY AND HOLD AMBIQ MICRO AND ITS OFFICERS, EMPLOYEES, SUBSIDIARIES, AFFILIATES, AND DISTRIBUTORS HARMLESS AGAINST ALL CLAIMS, COSTS, DAMAGES, AND EXPENSES, AND REASONABLE ATTORNEY FEES ARISING OUT OF, DIRECTLY OR INDIRECTLY, ANY CLAIM OF PERSONAL INJURY OR DEATH ASSOCIATED WITH SUCH UNINTENDED OR UNAUTHORIZED USE, EVEN IF SUCH CLAIM ALLEGES THAT AMBIQ MICRO WAS NEGLIGENT REGARDING THE DESIGN OR MANUFACTURE OF THE PART.

Revision History

Revision	Date	Description
1.0	December 25, 2018	Initial Issue
2.0	July 12, 2022	Added Apollo4 Blue series details
2.1	July 25, 2022	Updated document template

Reference Documents

Document ID	Description

Table of Contents

1. Overview	10
2. References	11
3. Definitions and Abbreviations	12
3.1 Definitions	12
3.2 Abbreviations	13
4. RF Test System	15
4.1 Conducted Test Configuration	15
4.2 Radiated Test Configuration	16
4.3 EUT Description	16
4.4 Test Command Summary	17
4.5 Environmental Condition	18
4.6 Measurement Uncertainty	19
5. Bluetooth Low Energy RF-PHY Test Guidance	20
5.1 Test Setup and Method	20
5.1.1 Signaling Test Method	21
5.1.2 Non-Signaling Test Method	22
5.1.3 UART Interface Characteristics	23
5.1.4 HCI RF Testing Command	23
5.2 Transmitter Test Cases	24
5.3 Receiver Test Cases	25
5.4 Special Declaration	27
6. SRRC Compliance Test Guidance	28
6.1 Test Items and Requirements	28
6.2 Peak Output Power	29
6.2.1 Measuring Parameter Settings	29
6.2.2 Explanation of Test Result	30
6.3 Frequency Tolerance	30
6.3.1 Measuring Parameter Settings	30
6.3.2 Explanation of Test Result	31

6.4 Frequency Range	32
6.4.1 Measuring Parameter Settings	32
6.4.2 Explanation of Test Result	32
6.5 Collateral Emissions of Transmitter	33
6.5.1 Measuring Parameter Settings	33
6.5.2 Explanation of Test Result	35
6.6 Collateral Emissions of Receiver	35
6.6.1 Measuring Parameter Settings	35
6.6.2 Explanation of Test Result	36
7. FCC Compliance Test Guidance	37
7.1 Test Items and Requirements	37
7.2 EUT Configuration	38
7.3 Output Power	39
7.3.1 Limit Requirement	39
7.3.2 Test Equipment Settings	39
7.3.3 Explanation of Test Result	39
7.4 Occupied Bandwidth	40
7.4.1 Limit Requirement	40
7.4.2 Test Equipment Settings	40
7.4.3 Explanation of Test Result	41
7.5 Conducted Spurious Emission	42
7.5.1 Limit Requirement	42
7.5.2 Test Procedure	42
7.5.2.1 Fundamental Emission Level Measurement	42
7.5.2.2 Spurious Emission Level Measurement	43
7.5.3 Test Equipment Settings	43
7.5.4 Explanation of Test Result	44
7.6 Radiated Spurious Emission	46
7.6.1 Limit Requirement	46
7.6.2 Test Setup	47
7.6.3 Test Procedure	48
7.6.4 Test Equipment Settings	49
7.6.5 Explanation of Test Result	50
7.7 Band Edge	51
7.7.1 Limit Requirement	51
7.7.2 Test Procedure	52
7.7.3 Test Equipment Settings	52
7.7.4 Explanation of Test Result	53
7.8 Power Spectral Density	54
7.8.1 Limit Requirement	54
7.8.2 Test Procedure	54

7.8.3 Test Equipment Settings	55
7.8.4 Explanation of Test Result	55
8. CE Conformance Test Guidance	56
8.1 Test Items and Requirements	56
8.2 EUT Configuration	57
8.3 RF Output Power	58
8.3.1 Definition and Limit	58
8.3.2 Test Equipment Settings	58
8.3.3 Explanation of Test Result	59
8.4 Power Spectral Density	59
8.4.1 Definition and Limit	59
8.4.2 Test Equipment Settings	60
8.5 Occupied Channel Bandwidth	60
8.5.1 Definition and Limit	60
8.5.2 Test Procedure	60
8.5.3 Explanation of Test Result	61
8.6 Transmitter Unwanted Emissions in the Out-of-Band Domain	62
8.6.1 Definition and Limit	62
8.6.2 Test Equipment Settings	62
8.6.3 Explanation of Test Result	63
8.7 Transmitter Unwanted Emissions in the Spurious Domain	64
8.7.1 Definition and Limit	64
8.7.2 Test Equipment Settings	65
8.8 Receiver Spurious Emissions	66
8.8.1 Definition and Limit	66
8.8.2 Test Equipment Settings	66
8.9 Receiver Blocking	67
8.9.1 Definition and Limit	67
8.9.2 Test Set-up	67
8.9.3 Test Procedure	68

List of Tables

Table 3-1 Abbreviation and Meaning	13
Table 4-1 Technical Information of the EUT Integrated with Apollo Series Bluetooth Low Energy SoCs	16
Table 4-2 Overall HCI Test Commands and SSCOM32 Strings	17
Table 4-3 Maximum Measurement Uncertainty	19
Table 5-1 Flash Programming Settings for Apollo SoC Family	21
Table 5-2 Definition of HCI Test Commands and SSCOM32 Strings	23
Table 5-3 Transmitter Test Cases and Requirements	24
Table 5-4 Receiver Test Cases and Requirements	25
Table 5-5 C/I and Receiver Selectivity Test Parameter Settings	26
Table 5-6 Out-of-Band Blocking Performance and Measurement Parameters	27
Table 5-7 Intermodulation Test Signal Allocation Alternatives in the Frequency Domain	27
Table 5-8 Special Declaration for Image Frequency and Value n	27
Table 6-1 SRRC Regulation Test Items and Requirements	28
Table 6-2 Frequency Range, Bandwidth and Limit Requirement of Collateral Emission Tests	29
Table 6-3 Spectrum Analyzer Settings of Peak Output Power Test	29
Table 6-4 Spectrum Analyzer Settings of Frequency Tolerance Test	31
Table 6-5 Spectrum Analyzer Settings of Frequency Range Test	32
Table 6-6 Spectrum Analyzer Settings While Transmitting at 2402 MHz	34
Table 6-7 Spectrum Analyzer Settings While Transmitting at 2440 MHz	34
Table 6-8 Spectrum Analyzer Settings While Transmitting at 2480 MHz	34
Table 7-1 Applicable Standards for FCC Compliance Test	37
Table 7-2 FCC Compliance Test Items and Requirements	37
Table 7-3 Transmitter Test Commands to Achieve 100% Duty Cycle	38
Table 7-4 Spectrum Analyzer Settings of Output Power Measurement	39
Table 7-5 Spectrum Analyzer Settings of Occupied Bandwidth Measurement	40
Table 7-6 Limit Requirement of Conducted Spurious Emission	42
Table 7-7 Spectrum Analyzer Settings of Reference Level Measurement	43
Table 7-8 Spectrum Analyzer Settings of Emission Level Measurement	44
Table 7-9 The Requirements for Radiated Emission	46
Table 7-10 The Requirements for Radiated Emission Above 1 GHz	46
Table 7-11 Spectrum Analyzer Settings of Occupied Bandwidth Measurement	49
Table 7-12 Limit Requirement of Band Edge Testing	51

Table 7-13 Spectrum Analyzer Settings of Reference Level Measurement	52
Table 7-14 Spectrum Analyzer Settings of Band Edge Measurement	53
Table 7-15 Spectrum Analyzer Settings of PSD Measurement	55
Table 8-1 Applicable Standards for CE Conformance Test	56
Table 8-2 Test Items and Requirements	56
Table 8-3 HCI Test Commands for Transmission to Achieve 100% Duty Cycle	57
Table 8-4 HCI Test Command for Receiver Parametric Test	57
Table 8-5 Spectrum Analyzer Settings for RF Output Power	58
Table 8-6 Spectrum Analyzer Settings for Power Spectral Density	60
Table 8-7 Spectrum Analyzer Settings for Occupied Channel Bandwidth	61
Table 8-8 Spectrum Analyzer Settings for Lower OOB Emissions	63
Table 8-9 Spectrum Analyzer Settings for Upper OOB Emissions	63
Table 8-10 Transmission Limits for Spurious Emissions	64
Table 8-11 Spectrum Analyzer Settings for 30 MHz to 1 GHz Band	65
Table 8-12 Spectrum Analyzer Settings for 1 GHz to 12.75 GHz Band	65
Table 8-13 Spurious Emission Limit for Receiver	66
Table 8-14 Receiver Blocking Parameters for Bluetooth Low Energy Equipments	67

List of Figures

Figure 3-1 Adjacent and Alternate Channel Definitions	12
Figure 4-1 Brief Block Diagram of Conducted Test System	15
Figure 4-2 Brief Block Diagram of Typical Radiated Test System	16
Figure 5-1 The Test Setup for Bluetooth Low Energy Signaling Test Method	21
Figure 5-2 The Test Setup for Bluetooth Low Energy Non-Signaling Test Method	22
Figure 6-1 Example Test Plot of Peak Output Power Testing	30
Figure 6-2 Example Test Plot of Frequency Tolerance Testing	31
Figure 6-3 Example Test Plot of Frequency Range Testing	33
Figure 6-4 Example Test Plot of Collateral Emissions of Transmitter	35
Figure 6-5 Example Test Plot of Collateral Emissions of Receiver	36
Figure 7-1 Example Test Plot of Maximum Conducted Output Power	40
Figure 7-2 Example Test Plot of Occupied Bandwidth in Low Channel	41
Figure 7-3 Example Test Plot of Fundamental Emission in High Channel	44
Figure 7-4 Example of Conducted Spurious Emission Test for 30 MHz to 3 GHz	45
Figure 7-5 Example of Conducted Spurious Emission Test for 2 to 25 GHz	45
Figure 7-6 Test Configuration of Radiated Emission Below 1 GHz	47
Figure 7-7 Test Configuration of Radiated Emissions Above 1 GHz	48
Figure 7-8 Radiated Emission Test Plot for 30 MHz to 1 GHz	50
Figure 7-9 Radiated Emission Test Plot for Above 1 GHz	50
Figure 7-10 Reference Level of Fundamental Emission Testing in Low Channel	53
Figure 7-11 Band Power Integral Over 1 MHz Relative to Emission Frequency	54
Figure 7-12 Example Test Plot of Power Spectral Density in Mid Channel	55
Figure 8-1 Example Declaration of Special Software Used in Test Report	57
Figure 8-2 Example Test Plot of RF Output Power at Middle Channel	59
Figure 8-3 Example Test Plot of Occupied Channel Bandwidth of 2402 MHz	61
Figure 8-4 Transmit Mask	62
Figure 8-5 Example Test Plot of OOB Emissions While Operating at Highest Frequency ..	64
Figure 8-6 Test Setup for Receiver Blocking Measurements	68

SECTION

1

Overview

The present document provides generally applicable procedures for testing and verifying the RF performance of wireless equipments employing Apollo series Bluetooth¹® Low Energy system on chips (SoCs), including but not limited to: guidance for regional regulation tests compliance with SRRC/FCC/CE regulatory standards, guidance for Bluetooth qualification tests conforming to Bluetooth RF-PHY test specification, and guidance for other common RF tests for the purpose of optimization and improvement during R&D process. Customers shall follow these procedures defined in the present document to perform pre-tests for radio type approval, conformance test and shorten time-to-market of products based on Apollo series Bluetooth Low Energy SoCs in-house.

¹The Bluetooth word mark and logos are registered trademarks owned by Bluetooth SIG, Inc. and any use of such marks by Ambiq Micro, Inc. is under license.

SECTION

2

References

1. ANSI C63.10-2013, American National Standard of Procedures for Compliance Testing of Unlicensed Wireless Devices
2. U.S. Code of Federal Regulations Title 47—Telecommunication, Chapter I—Federal Communications Commission, Part 15—Radio Frequency Devices, Subpart C—Intentional Radiators (47 CFR Part 15 Subpart C)
3. ETSI EN 300 328 V2.1.1, Wideband transmission systems; Data transmission equipment operating in the 2.4 GHz ISM band and using wide band modulation techniques; Harmonised Standard covering the essential requirements of article 3.2 of Directive 2014/53/EU
4. ETSI EN 300 440 V2.1.1, Short Range Devices (SRD); Radio equipment to be used in the 1 GHz to 40 GHz frequency range; Harmonised Standard covering the essential requirements of article 3.2 of Directive 2014/53/EU
5. Bluetooth RF-PHY.TS V4.2.2, Bluetooth® Test Specification, test structures and procedures for qualification testing of Bluetooth implementations of the Bluetooth Low Energy RF PHY

Definitions and Abbreviations

3.1 Definitions

For the purposes of this document, the following terms and definitions apply.

- **adjacent channels:** two channels on either side of the nominal channel separated by the nominal channel bandwidth.
- **alternate channels:** two channels on either side of the nominal channel separated by double the nominal channel bandwidth.

Figure 3-1: Adjacent and Alternate Channel Definitions

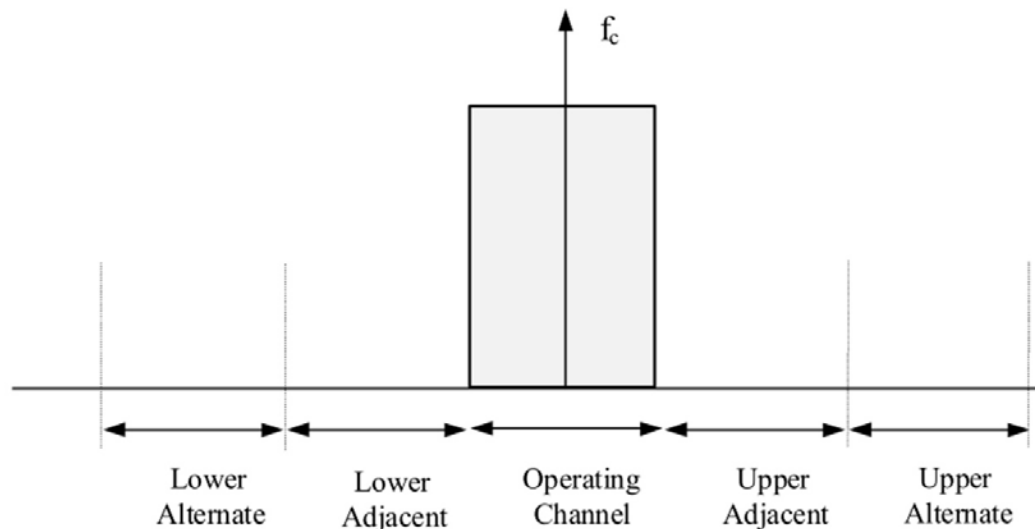

- **continuous transmit mode:** a mode in which the unlicensed wireless device is continuously transmitting at a 100% duty cycle.
- **conducted measurements:** measurements which are made using a direct connection to the EUT.

- **DTS bandwidth:** the minimum required 6 dB bandwidth for a DTS transmission.
- **emission bandwidth (EBW):** An unlicensed wireless device parameter determined by measuring the width of the signal between two points, one below the carrier center frequency and one above the carrier center frequency, which are 26 dB down relative to the maximum level of the modulated carrier based on the use of measurement instrumentation employing a peak detector function with an instrument resolution bandwidth approximately equal to 1.0% of the emission bandwidth of the device under measurement.
- **equipment under test (EUT):** A device or system being evaluated for compliance that is representative of a product to be marketed.
- **nominal channel bandwidth:** band of frequencies assigned to a single channel.
- **occupied bandwidth (OBW):** width of a frequency band such that, above the lower and below the upper frequency limits.
- **out-of-band emissions:** emission on a frequency or frequencies immediately outside the occupied bandwidth which results from the modulation process, but excluding spurious emissions.
- **power spectral density:** mean power in a given reference bandwidth.
- **radiated measurements:** measurements which involve the absolute measurement of a radiated field.
- **spurious emissions:** emissions on a frequency or frequencies which are outside the necessary bandwidth and the level of which may be reduced without affecting the corresponding transmission of information.

NOTE: Spurious emissions include harmonic emissions, parasitic emissions, intermodulation products and frequency conversion products, but exclude out-of-band emissions.

3.2 Abbreviations

For the purpose of this document, the following acronyms apply.

Table 3-1: Abbreviation and Meaning

Acronym	Meaning
DTM	Direct Test Mode
DTS	Digital Transmission System

Table 3-1: Abbreviation and Meaning (*Continued*)

Acronym	Meaning
EBW	Emission Bandwidth
EIRP	Equivalent Isotropically Raditated Power
ERP	Effective Radiated Power
EMC	Electromagnetic Compatibility
EMI	Electromagnetic Interference (Disturbance)
EUT	Equipment Under Test
GFSK	Gaussian Frequency Shift Keying
HCI	Host Controller Interface
LBT	Listen Before Talk
NSA	Normalized Site Attenuation
OBW	Occupied Bandwidth
PSD	Power Spectral Density
PER	Packet Error Rate
RBW	Resolution Bandwidth
RMS	Root Mean Square
VBW	Video Bandwidth
VSWR	Voltage Standing Wave Ratio

SECTION

4

RF Test System

4.1 Conducted Test Configuration

The general RF conducted test system shall be configured as Figure 4-1 below, composed of EUT, host computer, test instruments such as spectrum analyzer, signal generator, additional accessories, and so on, with physical connections among them. The EUT can be placed in a shield box (not shown in Figure 4-1) in order to improve measurement accuracy with elimination of some uncertain radio interference over the free space.

Figure 4-1: Brief Block Diagram of Conducted Test System

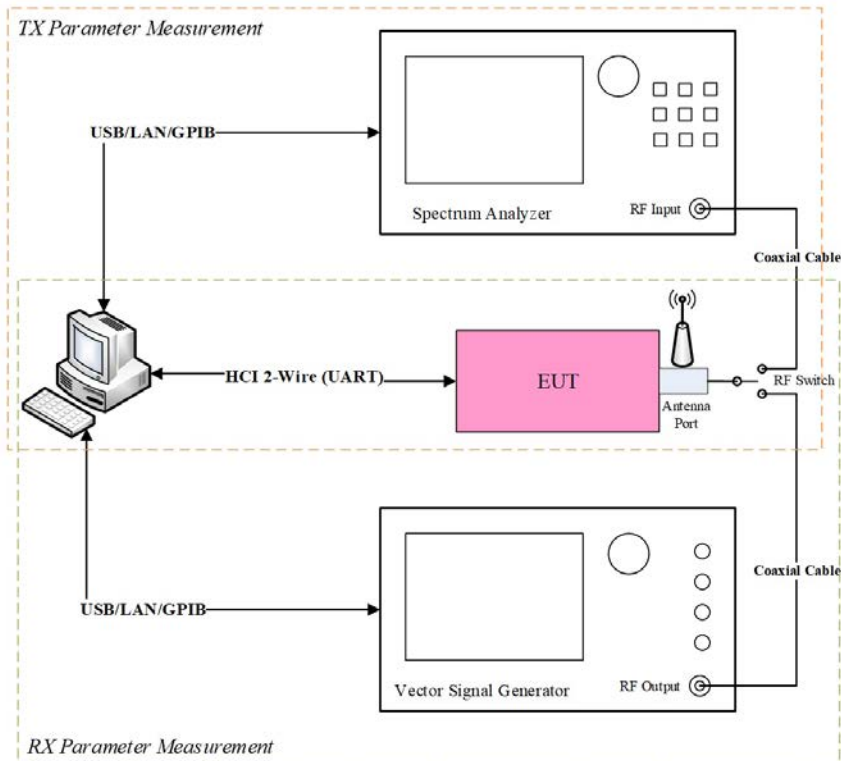

4.2 Radiated Test Configuration

The general RF radiated test system shall be configured as Figure 4-2 below, composed of EUT, standard receiving antenna that need to be placed in anechoic chamber, preamplifier, spectrum analyzer or EMI receiver, and so on. The semi-anechoic chamber has met the requirement of NSA tolerance 4dB and applied for frequency below 1 GHz. The full-anechoic chamber has met the requirement of VSWR tolerance 6 dB and applied for frequency above 1 GHz. The test distance was 3m for 30 MHz ~ 18 GHz.

Figure 4-2: Brief Block Diagram of Typical Radiated Test System

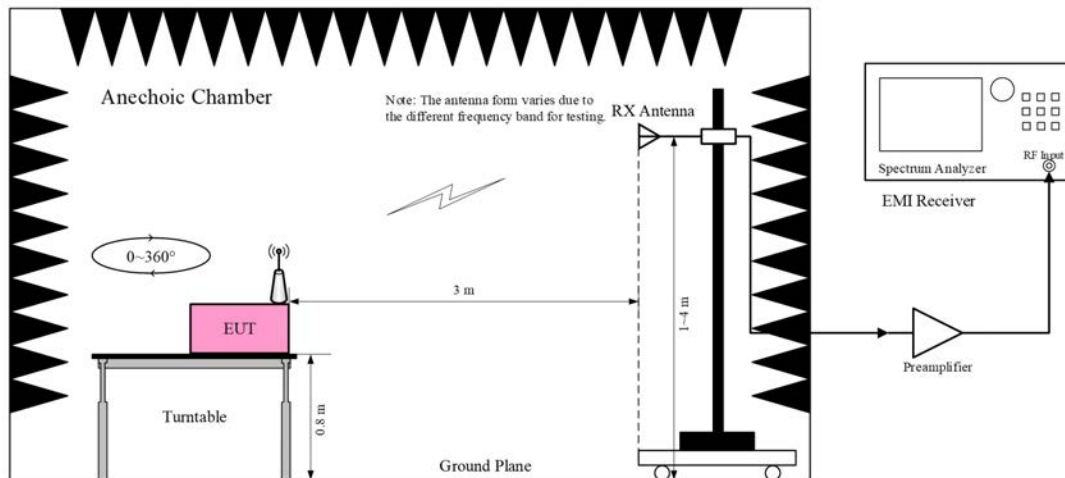

4.3 EUT Description

Since most of regulation tests, such as FCC and CE, have different requirements for different type of wireless product, please refer to the following technical information of EUTs based on Apollo series Bluetooth Low Energy SoCs listed in Table 4-1 below. The information shall be provided to third authorized test facility as an initial condition for testing and reflected in the final test report.

Table 4-1: Technical Information of the EUT Integrated with Apollo Series Bluetooth Low Energy SoCs

Item	Content
EUT type	Stand-alone equipment
Wireless connectivity	Bluetooth Low Energy 4.2 (Apollo2 Blue series) Bluetooth Low Energy 5.0 (Apollo3 Blue series) Bluetooth Low Energy 5.1 (Apollo4 Blue series)
Modulation types	DTS for FCC regulatory requirement Wide band modulation for CE regulatory requirement
Modulation technology	GFSK

Table 4-1: Technical Information of the EUT Integrated with Apollo Series Bluetooth Low Energy SoCs (*Continued*)

Item	Content
Data transfer rate	1Mbps (for Apollo3/2 Blue series) 1Mbps/2Mbps (for Apollo4 Blue series)
Operating frequency range	2400 ~ 2483.5 MHz ISM band
Number of channels	40 with intervals of 2 MHz
Channel under test	Low (2402 MHz), Middle (2440 MHz), High (2480 MHz)
Antenna type	Declared by the manufacturer
Antenna gain	Declared by the manufacturer
Smart Antenna System	N/A (FCC regulatory requirement only)
Beamforming Gain	N/A (CE regulatory requirement only)
Adaptive or non-adaptive	Adaptive (CE regulatory requirement only)
LBT or non-LBT based	LBT based (CE regulatory requirement only)
Receiver categories	Category 2 (CE regulatory requirement only)

4.4 Test Command Summary

For no matter Bluetooth Low Energy qualification test or regulatory test of EUT embedded with Apollo series Bluetooth Low Energy SoCs, the test commands defined in Table 4-2 below shall be used during each test process to configure EUT in correct test mode.

Table 4-2: Overall HCI Test Commands and SSCOM32 Strings

Packaged HCI Commands	Hexadecimal Strings	Description
HCI_RESET (Applicable for all)	01 03 0c 00	Reset EUT before each of tests.
HCI_LE_TRANSMITTER_TEST (Applicable for Apollo4/3/2 Blue LE1M mode)	01 1e 20 03 xx 25 00	'00' indicates normal test mode with PRBS9 sequence in payload.
	01 1e 20 03 xx 25 01	'01' indicates normal test mode with repeated 0x0F sequence.
	01 1e 20 03 xx 25 02	'02' indicates normal test mode with repeated 0x55 sequence.
HCI_LE_TRANSMITTER_TEST (Applicable for Apollo4 Blue LE2M mode)	01 34 20 04 xx 25 00 02	The same definition as above.
	01 34 20 04 xx 25 01 02	
	01 34 20 04 xx 25 02 02	
HCI_LE_TRANSMITTER_TEST (Vendor specific commands for Apollo4 Blue)	01 1e 20 03 xx 25 10	'10' indicates sending continuous carrier wave at center frequency
	01 1e 20 03 xx 25 11	'11' indicates continuous transmit mode with duty cycle = 100%
HCI_LE_TRANSMITTER_TEST (Vendor specific commands for Apollo3 Blue)	01 1e 20 03 xx 25 08	'08' indicates sending continuous carrier wave at center frequency.
	01 1e 20 03 xx 25 09	'09' indicates continuous transmit mode with duty cycle = 100%.

Table 4-2: Overall HCI Test Commands and SSCOM32 Strings

Packaged HCI Commands	Hexadecimal Strings	Description
HCI_EM_9304_TRANSMITTER_TEST (Vendor specific commands for Apollo2 Blue)	01 11 fc 04 01 xx 25 00	'01' indicates continuous transmit mode (PRBS9, duty cycle = 100%).
	01 11 fc 04 04 xx 25 00	'04' indicates continuous carrier wave at center frequency.
HCI_LE_RECEIVER_TEST (Applicable for Apollo4/3/2 in LE1M mode)	01 1d 20 01 xx	Set EUT in LE1M RX test mode.
HCI_LE_RECEIVER_TEST (Applicable for Apollo4 Blue in LE2M mode)	01 33 20 03 xx 02 00	Set EUT in LE2M RX test mode.
HCI_LE_TEST_END (Applicable for all)	01 1f 20 00	Stop the current test and be ready for the next one.

NOTES:

- Normal test mode means Direct Test Mode (DTM) for Bluetooth Low Energy RF-PHY qualification test specified in Bluetooth Core Specification and Test Specification.
- 'xx' in all hexadecimal strings above indicates the frequency of channel to be tested, which can be assigned with a range of 0x00~0x27.
- '0x25' in transmitter test commands above means typical payload length in a test packet = 37 octets, and which can be customized under the maximum limit of 255 octets.
- In Direct Test Mode, the longer test packet length is used, the higher duty cycle can test reach. When setting payload length to the maximization of 255 octets, the duty cycle \approx 90%.

4.5 Environmental Condition

Unless otherwise specified, the normal test environmental conditions shall be set as below:

1. Ambient Temperature: 15°C ~ 35°C;
2. Relative humidity: 25% ~ 75%;
3. Atmospheric Pressure: 86 kPa ~ 106 kPa.

Some tests in the present document need to be repeated at extreme temperatures. In this case, extreme test conditions of the operating temperature range for EUTs embedded with Apollo series Bluetooth Low Energy SoCs shall be set as below:

1. Low Temperature: -40°C
2. High Temperature: +85°C

4.6 Measurement Uncertainty

The results of measurements of emissions from transmitters should reference the measurement instrumentation uncertainty considerations. Determining compliance should be based on the results of the compliance measurement, not taking into account measurement instrumentation uncertainty. Hence, the measurement uncertainty of the measurement instrumentation and its associated connections between the various instruments in the measurement chain should be calculated, and both the measurement results and the calculated uncertainty should be given in the test report.

For the test methods, according to the present document, the measurement uncertainty figures shall be calculated and shall correspond to an expansion factor (coverage factor) $k = 1.96$ or $k = 2$ (which provide confidence levels of respectively 95% and 95.45% in the case where the distributions characterizing the actual measurement uncertainties are normal (Gaussian)). The calculated value of the measurement uncertainty shall be equal to or less than the figures in Table 4-3 below for each measurement.

Table 4-3: Maximum Measurement Uncertainty

Measuring Parameter	Uncertainty Value
Occupied Channel Bandwidth	±5%
RF Output Power, conducted	±1.5 dB
Power Spectral Density, conducted	±3 dB
Unwanted Emissions, conducted	±3 dB
All emissions, radiated	±6 dB
Supply Voltages	±3%
Time	±5%
Temperature	±3°C
Humidity	±5%

SECTION

5

Bluetooth Low Energy RF-PHY Test Guidance

Bluetooth Low Energy devices operate in the unlicensed 2.4GHz ISM frequency band at 2400-2483.5 MHz. The Bluetooth Low Energy system uses 40 RF channels that have center frequencies $2402 + n \times 2$ MHz, where $n = 0, 1, 2, \dots, 39$.

The Bluetooth Low Energy RF-PHY is the lowest layer of the Bluetooth Low Energy protocol stack. For simplicity and intuitive, this chapter lists all test cases and requirements for Bluetooth qualification testing of equipments employing Apollo series Bluetooth Low Energy SoCs only, while regarding test procedures and definition for each test case, refer to Bluetooth® Test Specification RF-PHY.TS V4.2.2 for details. The two primary objectives of the Bluetooth Low Energy RF-PHY qualification tests are: 1) to ensure interoperability between all Bluetooth Low Energy devices in the marketplace; 2) to verify that a basic level of system performance is guaranteed for all Bluetooth Low Energy products.

The Bluetooth Low Energy RF-PHY qualified test cases may be divided into two categories: transmitter tests and receiver tests. Under RF-PHY test mode, hopping is disabled and the EUT's transmit and receive frequencies are set fixedly according to specific test cases.

5.1 Test Setup and Method

For Bluetooth Low Energy RF-PHY test, EUT shall be configured as Direct Test Mode (DTM) through burning test program at first. This test program is called test bridge for Apollo Bluetooth Low Energy SoC family. Follow the settings given in Table 5-1 when using J-Flash tool to download test program.

Table 5-1: Flash Programming Settings for Apollo SoC Family

Chip Model	Target Device Type	Interface	Speed	Programming Start Address
Apollo2 Blue	AMAPH1KK-KBR	SWD	4000 kHz	0x00000000
Apollo3 Blue	AMA3B1KK-KBR			0x0000C000
Apollo3 Blue Plus	AMA3B2KK-KBR			0x0000C000
Apollo4 Blue Series	AMAP42KK-KBR AMA4B2KK-KBR			0x00018000

Direct Test Mode (DTM) is used to control the EUT and provides a report back to the Bluetooth tester. It shall be set up using one of two alternate methods: over HCI or through a 2-wire UART interface. Due to non-accessible HCI design for Apollo Bluetooth Low Energy SoC family, a 2-wire UART interface is routed out for transferring RF testing commands. However, no matter Bluetooth testers or computers, they do not have any built-in UART interface but plenty of USB interface resources, hence one USB-to-UART adapter is needed for protocol translation use.

5.1.1 Signaling Test Method

One typical test setup connection between EUT, Bluetooth tester, and/or host computer is shown in Figure 5-1, which RF testing commands are automatically generated by tester and this may be called Bluetooth signaling test method. Note that the host computer is optional since when only running test scripts and generating test report automatically can it be needed.

Figure 5-1: The Test Setup for Bluetooth Low Energy Signaling Test Method

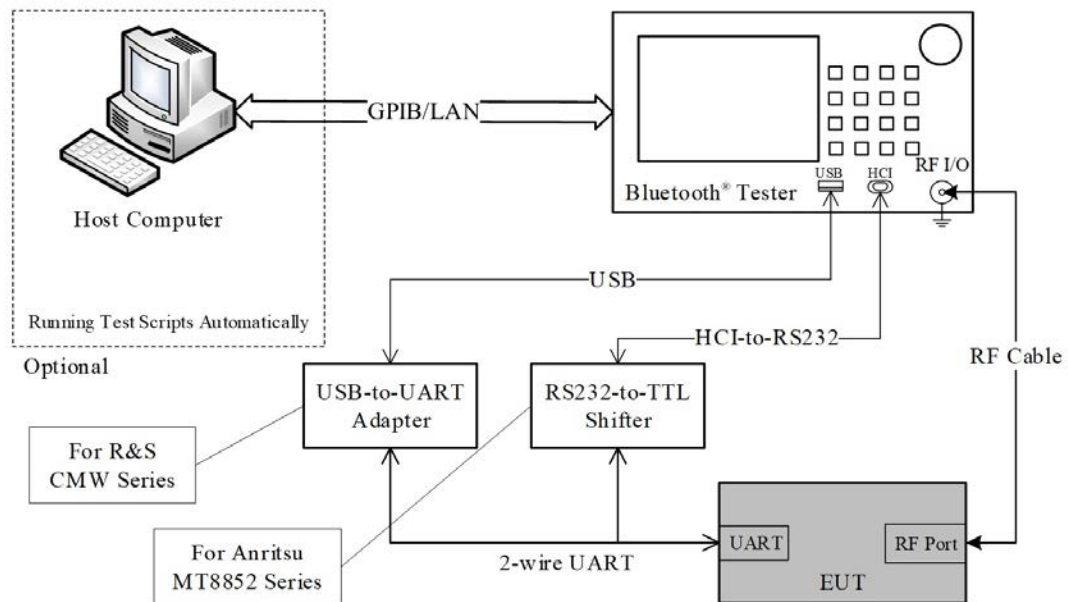

There are two most commonly used Bluetooth Tester models: R&S CMW series wideband radio communication tester and Anritsu MT8852 series Bluetooth test set. When USB-to-UART adapter is used, the driver must be installed on tester or computer appropriately at first.

Due to RF testing commands can be only transferred over built-in HCI interface on MT8852 series tester, one HCI-to-RS232 adapter cable and one RS232-to-TTL shifter are needed instead of USB-to-UART adapter as shown in Figure 5-1 on page 21.

Generally, R&S CMW series Bluetooth tester is recommended for R&D use since it can be operated more flexibly, while Anritsu MT8852 series Bluetooth tester is more suitable for production test since it can run testing scripts and generate test report automatically.

5.1.2 Non-Signaling Test Method

Another test setup connection which is called non-signaling test method is shown in Figure 5-2 below. In this case, RF testing commands defined in Table 5-2 on page 23 are sent by PC test software manually. Note that only R&S CMW series tester can support this method.

Figure 5-2: The Test Setup for Bluetooth Low Energy Non-Signaling Test Method

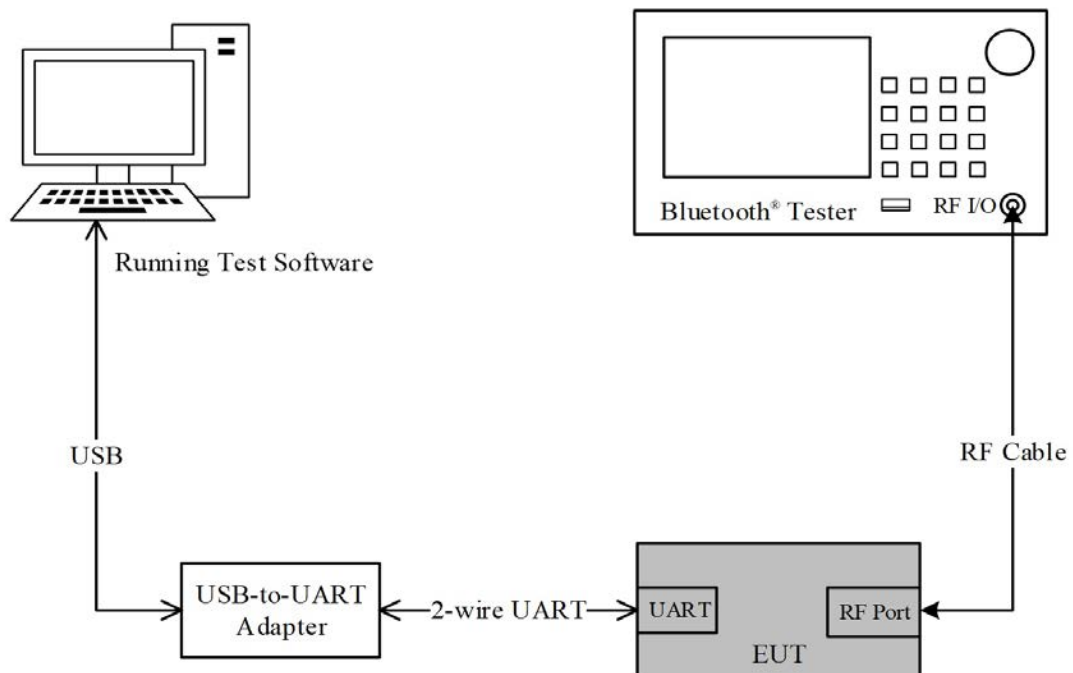

5.1.3 UART Interface Characteristics

Apollo series Bluetooth Low Energy SoCs have two mainstream power supply schemes: 1.8V or 3.3V. Thus, the TTL level of UART interface on USB-to-UART adapter must be consistent with what power supply rail is used on EUT to avoid incapable of communication between them. The UART test interface characteristics of Apollo based EUTs shall be set to use the following parameters:

- Baud rate: 115200
- Number of data bits: 8
- No parity
- 1 stop bit
- No flow control (RTS or CTS)

5.1.4 HCI RF Testing Command

As defined in Table 4-2 on page 17, for all test cases of Bluetooth Low Energy RF-PHY, if non-signaling test method is utilized, then the RF testing commands listed in Table 5-2 shall be sent over PC test software manually during each test process to control EUT.

Table 5-2: Definition of HCI Test Commands and SSCOM32 Strings

Packaged HCI Commands	Hexadecimal Strings	Description
HCI_RESET	01 03 0c 00	Reset EUT before each of tests.
HCI_LE_TRANSMITTER_TEST (Applicable for Apollo4/3/2 Blue LE1M mode)	01 1e 20 03 xx 25 00	'0x00' means transmitting PRBS9 sequence in payload field
	01 1e 20 03 xx 25 01	'0x01' means transmitting repeated '11110000' sequence in payload field
	01 1e 20 03 xx 25 02	'0x02' means transmitting repeated '10101010' sequence in payload field
HCI_LE_TRANSMITTER_TEST (Applicable for Apollo4 Blue LE2M mode)	01 34 20 04 xx 25 00 02	The same definition as above.
	01 34 20 04 xx 25 01 02	
	01 34 20 04 xx 25 02 02	
HCI_LE_RECEIVER_TEST (Applicable for Apollo4 Blue LE1M mode)	01 1d 20 01 xx	Set EUT in LE1M RX test mode.
HCI_LE_RECEIVER_TEST (Applicable for Apollo4 Blue LE2M mode)	01 33 20 03 xx 02 00	Set EUT in LE2M RX test mode.
HCI_LE_TEST_END	01 1f 20 00	Terminate the current test.

NOTES:

- 'xx' in all hexadecimal strings above indicates the frequency of channel to be tested, which can be assigned with a value within 0x00~0x27 corresponding to Channel 0 to 39.
- '0x25' in transmitter test commands above means typical payload length in a test packet = 37 octets, and which can be customized under the maximum limit of 255 octets (0xFF).
- In direct RX test mode, it will return the valid number of received packets (2 octets) through sending HCI_LE_RECEIVER_TEST command followed by HCI_LE_TEST_END command, then the PER can be calculated out according to the number of received packets.
- After sending each command listed above, EUT will return LE_STATUS packet where the last octet of it signifies whether the present command is processed successfully or not.

5.2 Transmitter Test Cases

There are 4 test cases in Bluetooth Low Energy qualified transmitter tests (TRM-LE) for EUT embedded with Apollo series Bluetooth Low Energy SoCs in total. The test items, requirements, payload pattern and RF channels (frequencies) for testing are listed in Table 5-3 below.

Table 5-3: Transmitter Test Cases and Requirements

Test Items	Limit Requirement	Sending Payload Type	RF Channels (Frequencies) for Testing
Output Power	$-20 \text{ dBm} \leq P_{\text{AVG}} \leq +10 \text{ dBm}$ $P_{\text{PEAK}} - P_{\text{AVG}} \leq 3 \text{ dB}$	PRBS9 sequence	0 (2402 MHz)
			12 (2426 MHz)
			19 (2440 MHz)
			39 (2480 MHz)
In-Band Emissions	$P_{\text{TX}} \leq -20 \text{ dBm}$ for $(f_{\text{TX}} \pm 2 \text{ MHz})$ $P_{\text{TX}} \leq -30 \text{ dBm}$ for $(f_{\text{TX}} \pm n \text{ MHz})$; where $n \geq 3$	PRBS9 sequence	0 (2402 MHz)
			2 (2406 MHz)
			12 (2426 MHz)
			19 (2440 MHz)
			37 (2476 MHz)
Modulation Characteristics	$225 \text{ kHz} \leq \Delta f_{1\text{avg}} \leq 275 \text{ kHz}$ $99.9\% \Delta f_{2\text{max}} \leq 185 \text{ kHz}$ $\Delta f_{2\text{avg}} / \Delta f_{1\text{avg}} \geq 0.8$	$\Delta f_{1\text{avg}}$: 11110000 sequence $\Delta f_{2\text{avg}}$: 10101010 sequence	0 (2402 MHz)
			12 (2426 MHz)
			19 (2440 MHz)
			39 (2480 MHz)

Table 5-3: Transmitter Test Cases and Requirements (*Continued*)

Test Items	Limit Requirement	Sending Payload Type	RF Channels (Frequencies) for Testing
Carrier Frequency Offset and Drift	Freq Offset (Accuracy) $\leq \pm 150$ kHz Freq Drift $\leq \pm 50$ kHz Initial frequency drift $\leq \pm 23$ kHz Maximum drift rate ≤ 20 kHz/50 μ s	10101010 sequence	0 (2402 MHz)
			12 (2426 MHz)
			19 (2440 MHz)
			39 (2480 MHz)

NOTES:

- The EUT is connected to the tester via a 50 Ω connector. If there is no antenna interface, a temporary 50 Ω interface such as one pig-tail cable may be used.
- The EUT is set to direct TX mode at maximum output power on fixed channel (frequency hopping off) for each test case.

5.3 Receiver Test Cases

There are 6 test cases in Bluetooth Low Energy RF-PHY receiver tests (RCV-LE) for EUT embedded with Apollo series Bluetooth Low Energy SoCs in total. The test items, requirements, conditions and RF channels (frequencies) for testing are listed in Table 5-4 below.

Table 5-4: Receiver Test Cases and Requirements

Test Items	Limit Requirement	Test Conditions	RF Channels (Frequencies) for Testing
Receiver Sensitivity	PER $\leq 30.8\%$ when input power level = -70 dBm	Receive a minimum of 1500 test packets with 37-byte PRBS9 payload in dirty transmitter mode.	0 (2402 MHz)
			12 (2426 MHz)
			19 (2440 MHz)
			39 (2480 MHz)
PER Report Integrity	50% \leq PER \leq 65.4% when input power level = -30 dBm	Receive 1500 test packets with intentionally corrupted CRC value.	12 (2426 MHz)
			19 (2440 MHz)
Maximum Input Signal Level	PER $\leq 30.8\%$ when input power level = -10 dBm	Receive a minimum of 1500 test packets with 37-byte PRBS9 payload in direct RX mode.	0 (2402 MHz)
			12 (2426 MHz)
			19 (2440 MHz)
			39 (2480 MHz)
C/I and Receiver Selectivity Performance	PER $\leq 30.8\%$ when C/I test parameter settings meet the requirements defined in Table 5-5 on page 26.	Receive a minimum of 1500 test packets with 37-byte PRBS9 payload in direct RX mode.	0 (2402 MHz)
			2 (2406 MHz)
			19 (2440 MHz)
			37 (2476 MHz)
			39 (2480 MHz)

Table 5-4: Receiver Test Cases and Requirements (*Continued*)

Test Items	Limit Requirement	Test Conditions	RF Channels (Frequencies) for Testing
Blocking Performance	PER \leq 30.8% when out-of-band blocking test parameter settings meet the requirements defined in Table 5-6 on page 27.	Receive a minimum of 1500 test packets with 37-byte PRBS9 payload in direct RX mode.	12 (2426 MHz)
Intermodulation Performance	PER \leq 30.8% when test signal allocation alternatives meet the requirements defined in Table 5-7 on page 27.	Receive a minimum of 1500 test packets with 37-byte PRBS9 payload in direct RX mode.	0 (2402 MHz)
			12 (2426 MHz)
			19 (2440 MHz)
			39 (2480 MHz)

NOTES:

- The EUT is connected to the tester via a 50 Ω connector. If there is no antenna interface, a temporary 50 Ω interface such as one pig-tail cable may be used.
- The EUT is set to direct RX mode on fixed channel (frequency hopping off) for each test case.
- In receiver sensitivity test case, the dirty transmitter shall apply where the characteristics of test packets transmitted by tester, including frequency offset, frequency drift, modulation index and symbol timing error, etc., are not ideal and changed over time as specified in Bluetooth Test Specification.

Table 5-5: C/I and Receiver Selectivity Test Parameter Settings

Interference Frequency	Wanted Signal (PRB69) Power Level (dBm)	Interference (PRBS15) Power Level (dBm)	C/I Requirement (db)
Co-channel	-67	-88	21
Adjacent (\pm 1MHz)	-67	-82	15
Adjacent (\pm 2MHz)	-67	-50	-17
Adjacent [\pm (3+n) MHz]	-67	-40	-27
Image Frequency	-67	-58	-9
Adjacent (\pm 1MHz) to image frequency	-67	-52	-15

NOTE: If two frequencies defined above refer to the same physical channel, the less stringent requirement will apply.

Table 5-6: Out-of-Band Blocking Performance and Measurement Parameters

Interference Signal Frequency Range	Wanted Signal (PRBS9) Power Level (dBm)	Blocking Signal (Carrier Wave) Power Level (dBm)	Frequency Step Size (MHz)
30 ~ 2000 MHz	-67	-30	10 MHz
2003 ~ 2399 MHz	-67	-35	3 MHz
2484 ~ 2997 MHz	-67	-35	3 MHz
3 ~ 12.75 GHz	-67	-30	25 MHz

Table 5-7: Intermodulation Test Signal Allocation Alternatives in the Frequency Domain

Testing Signals	Signal Type	Power Level at RF Port	Frequency Relation Between Wanted Signal & Interferences
Wanted signal f_0	Modulated signal with PRBS9 payload	-64 dBm	$f_0 = 2*f_1 - f_2$ and $ f_2 - f_1 = n*1$ MHz where $n = 3, 4$ or 5
Interference signal f_1	Sinusoidal, Un-modulated carrier wave	-50 dBm	
Interference signal f_2	Continuous modulated signal with PRBS15 data	-50 dBm	

5.4 Special Declaration

Due to differences in receiver architecture design between different chip manufacturers, the in-band image frequency (f_{image}) relative to the receiver frequency for C/I and receiver selectivity test, and the value of n for intermodulation test shall be declared to the testing facility by EUT manufacturer before performing formal qualification tests. For EUT embedded with Apollo series Bluetooth Low Energy SoCs, these two values shall be set as follows.

Table 5-8: Special Declaration for Image Frequency and Value n

Identifier	Apollo4 Blue	Apollo3 Blue	Apollo2 Blue	Units
In-band image frequency relative to receiver frequency	0	-4	78	MHz
Value n for intermodulation test	5	5	3	integer

SECTION

6

SRRC Compliance Test Guidance

SRRC is short for State Radio Regulatory Commission of P.R China, which is mandatory wireless certification requirement for those products with radio functions intended to be sold in mainland China. All wireless communication products sold and used within China must apply for radio type approval certification.

The Bluetooth Low Energy RF-PHY qualified test cases may be divided into two categories: transmitter tests and receiver tests. Under RF-PHY test mode, hopping is disabled and the EUT's transmit and receive frequencies are set fixedly according to specific test cases.

6.1 Test Items and Requirements

Table 6-1: SRRC Regulation Test Items and Requirements

No.	Items	Limit Requirements	Channels for Testing	Test Mode
1	Peak Output Power	$EIRP \leq 10\text{dBm}$	Low/Mid/High	Continuous Transmit Mode
2	Frequency Tolerance	$\pm 20\text{ ppm}$ (~50 kHz)	Low/Mid/High	Continuous Carrier Wave at Center Freq
3	Frequency Range (Band edge)	$EIRP \leq -30\text{ dBm}$ at 2400 or 2483.5MHz	Low/High	Continuous Transmit Mode
4	Collateral emissions of transmitter	See Table 6-2	Low/Mid/High	Continuous Transmit Mode
5	Collateral emissions of receiver	See Table 6-2	Low/Mid/High	Receiver Mode

Table 6-2: Frequency Range, Bandwidth and Limit Requirement of Collateral Emission Tests

Start Freq (MHz)	Stop Freq (MHz)	RBW (MHz)	VBW (MHz)	Detector Mode	Limit (dBm)
30	1000	0.1	$\geq 3 \times \text{RBW}$	Peak	-36
2400	2483.5	0.1	$\geq 3 \times \text{RBW}$	Peak	-33
3400	3530	1	$\geq 3 \times \text{RBW}$	Peak	-40
5725	5850	1	$\geq 3 \times \text{RBW}$	Peak	-40
Other frequency bands within 1~12.75GHz		1	$\geq 3 \times \text{RBW}$	Peak	-30

6.2 Peak Output Power

6.2.1 Measuring Parameter Settings

- Measurement Instrument Type: Spectrum Analyzer
- Test Mode: Continuous Transmit Mode (duty cycle = 100%)
- Measuring Parameter: Maximum Conducted Output Power
- HCI Test Commands and SSCOM32 Strings: See Table 4-2 on page 17.
- Spectrum Analyzer Settings: See Table 6-3 below

NOTE: EIRP = Conducted Power + Antenna Gain (default value: 0 dBi).

Table 6-3: Spectrum Analyzer Settings of Peak Output Power Test

Setting Parameters of SA	Value
Center Frequency	2402 / 2440 / 2480 MHz
Span	3 MHz
RBW (Resolution Bandwidth)	3 MHz
VBW (Video Bandwidth)	3 MHz
Detector Mode	Peak
Sweep Time	Auto
Trace Mode	Max Hold

6.2.2 Explanation of Test Result

Figure 6-1: Example Test Plot of Peak Output Power Testing

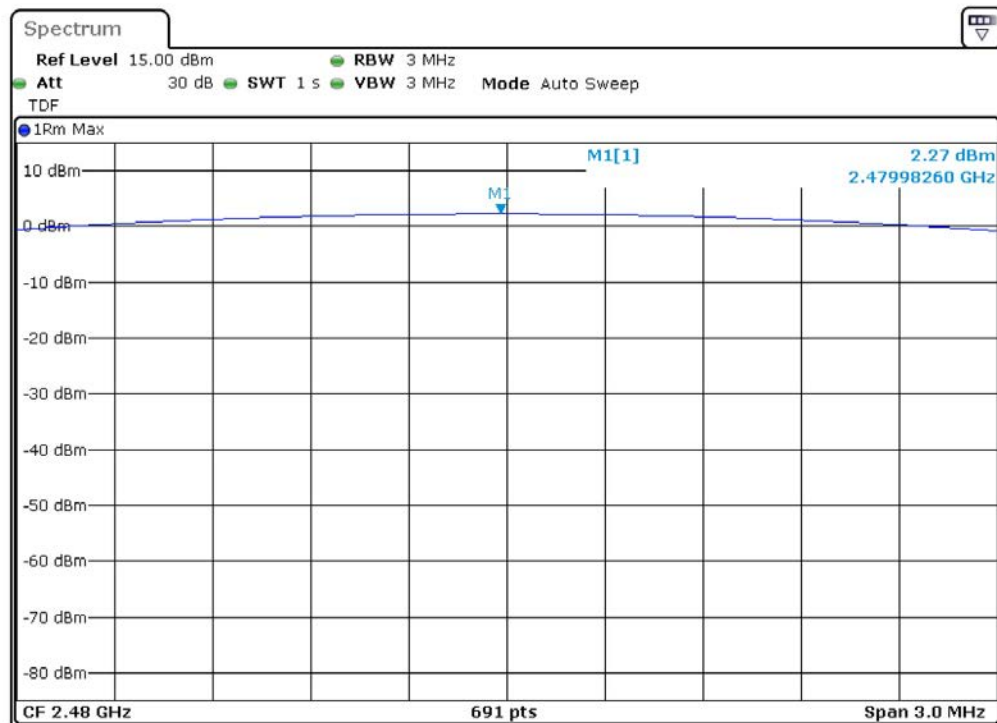

Figure 6-1 shows a typical spectrum and related settings displayed on the screen of spectrum analyzer while performing the peak output power test per SRRRC. Note that the RBW should be greater than Bluetooth Low Energy channel bandwidth (e.g., 2 MHz) and the peak search function should be used to determine the maximum amplitude level until the trace is fully stabilized. In addition, the offset level should be set in the spectrum analyzer to compensate the RF cable loss and attenuation between antenna connector of EUT and RF input port of spectrum analyzer. With the offset compensation value, the reading level in spectrum analyzer is exactly equal to the RF output power level of EUT.

6.3 Frequency Tolerance

6.3.1 Measuring Parameter Settings

- Measurement Instrument Type: Spectrum Analyzer
- Test Mode: Continuous Carrier Wave at Center Frequency
- Measuring Parameter: Frequency offset relative to nominal frequency
- HCI Test Commands and SSCOM32 Strings: See Table 4-2 in *Section 4.4 Test Command Summary* on page 17.

- Spectrum Analyzer Settings: See Table 6-4 on page 31

Table 6-4: Spectrum Analyzer Settings of Frequency Tolerance Test

Setting Parameters of SA	Value
Center Frequency	2402 / 2440 / 2480 MHz
Span	100 kHz
RBW (Resolution Bandwidth)	10 kHz
VBW (Video Bandwidth)	10 kHz
Detector Mode	Peak / Average
Sweep Time	Auto
Trace Mode	Free Run

6.3.2 Explanation of Test Result

The following Figure 6-2 shows a typical spectrum and related settings displayed on the screen of test instrument while performing the frequency tolerance test per SRRRC. Note that the window size (e.g., span) is set as test limit requirement $\pm 20\text{ppm}$ which is approximately equal to $\pm 50\text{ kHz}$. The test result can be judged as pass as long as the peak value of carrier wave falls in the window (see Marker 1 in Figure 6-2 below). Otherwise, it shall be regarded as fail.

Figure 6-2: Example Test Plot of Frequency Tolerance Testing

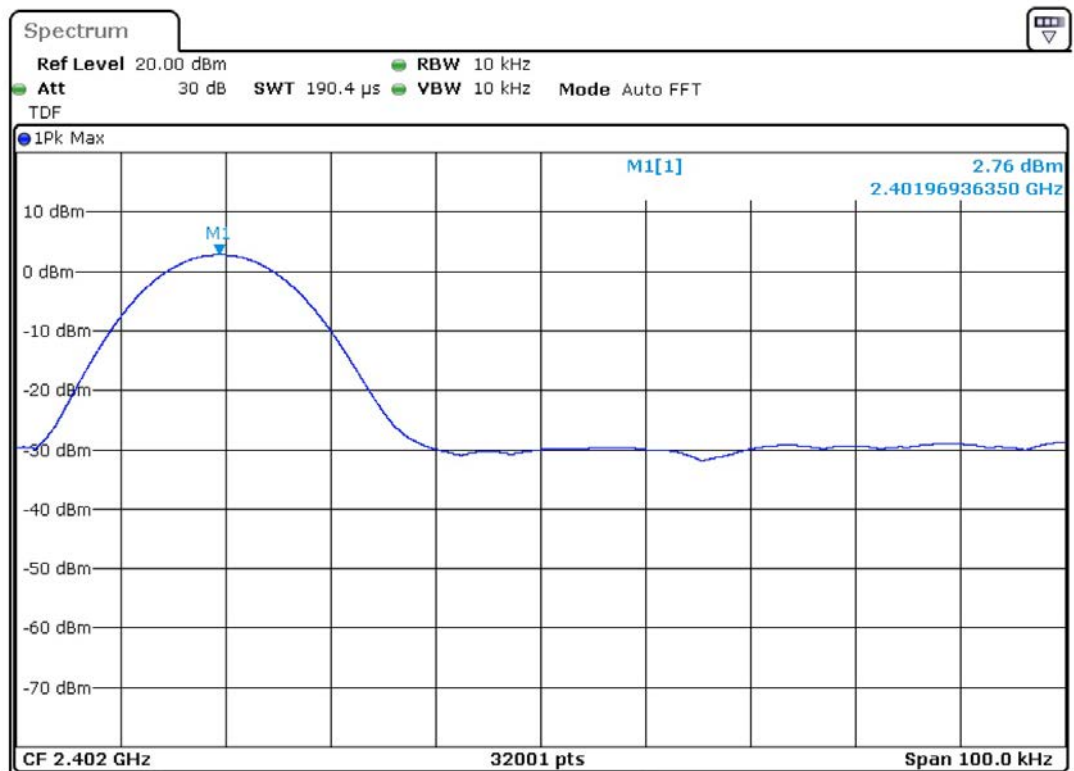

6.4 Frequency Range

6.4.1 Measuring Parameter Settings

- Measurement Instrument Type: Spectrum Analyzer
- Test Mode: Continuous Transmit Mode (duty cycle = 100%)
- Measuring Parameter: Maximum emission at edge of 2400~2483.5 MHz band
- HCI Test Commands & SSCOM32 Strings: See Table 4-2 in *Section 4.4 Test Command Summary on page 17*.
- Spectrum Analyzer Settings: See Table 6-5 below

Table 6-5: Spectrum Analyzer Settings of Frequency Range Test

Setting Parameters of SA	Value
Center Frequency	2402 / 2480 MHz
Span	5 MHz at 2402 MHz / 10 MHz at 2480 MHz
RBW (Resolution Bandwidth)	100 kHz
VBW (Video Bandwidth)	100 kHz
Detector Mode	Peak
Sweep Time	Auto
Trace Mode	Max Hold

6.4.2 Explanation of Test Result

The following Figure 6-3 on page 33 shows a typical spectrum and related settings displayed on the display while performing the band edge test per SRRRC. Note that the marker 1 in Figure 6-3 should be placed at 2400 MHz and its reading level indicates the emission at lower band edge. There are two methods of pass/fail verdict which one way is reading emission level at lower or upper band edge and see if it is less than -30 dBm; the other way is seeking the points with -30 dBm value and see if they fall within 2400~2483.5 MHz band.

Figure 6-3: Example Test Plot of Frequency Range Testing

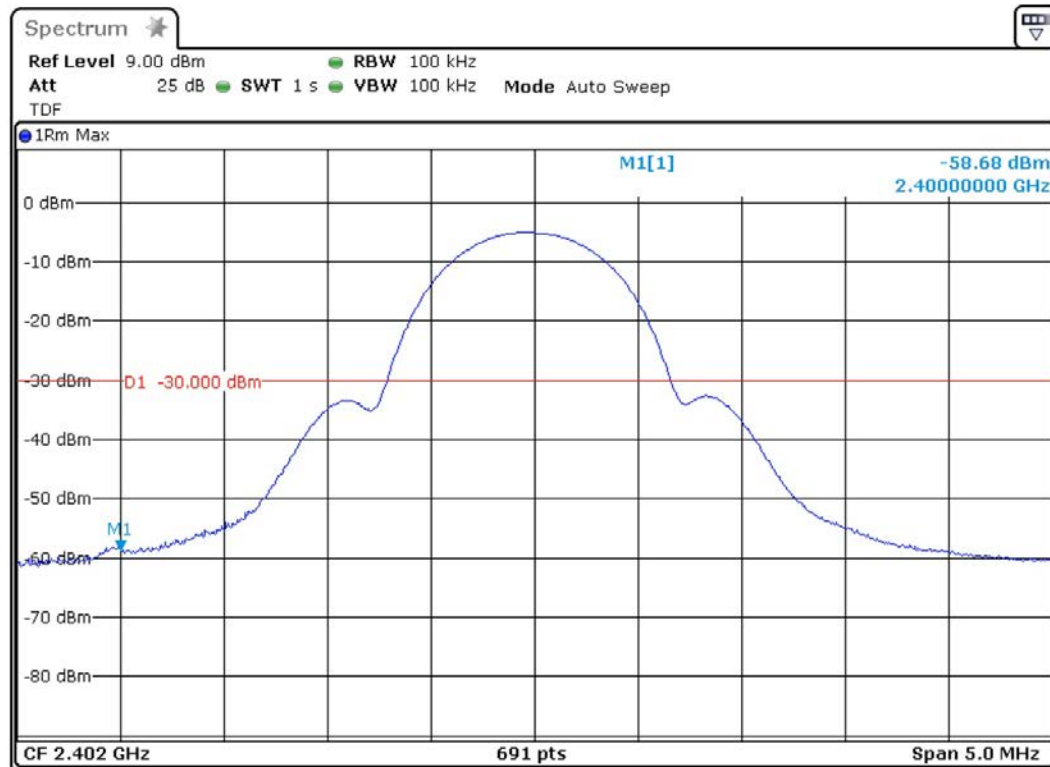

6.5 Collateral Emissions of Transmitter

6.5.1 Measuring Parameter Settings

- Measurement Instrument Type: Spectrum Analyzer
- Test Mode: Continuous Transmit Mode (duty cycle = 100%)
- Measuring Parameter: Peak amplitude value within all frequency bands
- HCI Test Commands SSCOM32 Strings: See Table 4-2 in *Section 4.4 Test Command Summary on page 17*
- Spectrum Analyzer Settings: See Table 6-6 on page 34, Table 6-7 on page 34, and Table 6-8 on page 34

When performing spurious emissions test at 2402 MHz (Ch0), the instrumental parameter settings of spectrum analyzer are shown as below:

Table 6-6: Spectrum Analyzer Settings While Transmitting at 2402 MHz

Frequency Band (MHz)	RBW (MHz)	VBW (MHz)	Sweep Time	Detector Mode & Trace Mode	Limit (dBm)
30~1000	0.1	1	10 ms	Peak Max Hold	-36
1000~2397	1	3	1.5 ms		-30
2407~2483.5	0.1	3	95 μ s		-33
2483.5~3400	1	3	1 ms		-30
3400~3530	1	3	19 μ s		-40
3530~5725	1	3	2.2 ms		-30
5725~5850	1	3	17 μ s		-40
5850~12750	1	3	10 s		-30

When performing spurious emissions test at 2440 MHz (Ch19), the instrumental parameter settings of spectrum analyzer are shown as below:

Table 6-7: Spectrum Analyzer Settings While Transmitting at 2440 MHz

Frequency Band (MHz)	RBW (MHz)	VBW (MHz)	Sweep Time	Detector Mode & Trace Mode	Limit (dBm)
30~1000	0.1	1	10 ms	Peak Max Hold	-36
1000~2400	1	3	1.5 ms		-30
2400~2435	0.1	3	38 μ s		-33
2445~2483.5	0.1	3	57 μ s		-33
2483.5~3400	1	3	1 ms		-30
3400~3530	1	3	19 μ s		-40
3530~5725	1	3	2.2 ms		-30
5725~5850	1	3	17 μ s		-40
5850~12750	1	3	10 s	-30	

When performing spurious emissions test at 2480 MHz (Ch39), the instrumental parameter settings of spectrum analyzer are shown as below:

Table 6-8: Spectrum Analyzer Settings While Transmitting at 2480 MHz

Frequency Band (MHz)	RBW (MHz)	VBW (MHz)	Sweep Time	Detector Mode & Trace Mode	Limit (dBm)
30~1000	0.1	1	10 ms	Peak Max Hold	-36
1000~2400	1	3	1.5 ms		-30
2400~2475	0.1	3	95 μ s		-33
2483.5~3400	1	3	1 ms		-30
3400~3530	1	3	19 μ s		-40
3530~5725	1	3	2.2 ms		-30
5725~5850	1	3	17 μ s		-40
5850~12750	1	3	10 s		-30

6.5.2 Explanation of Test Result

Figure 6-4 shows an overall example test plot while performing collateral emissions of transmitter at the lowest channel of EUT. The peak amplitude level within each segment of frequency band shall be listed in test record for determining compliance with requirement above.

Figure 6-4: Example Test Plot of Collateral Emissions of Transmitter

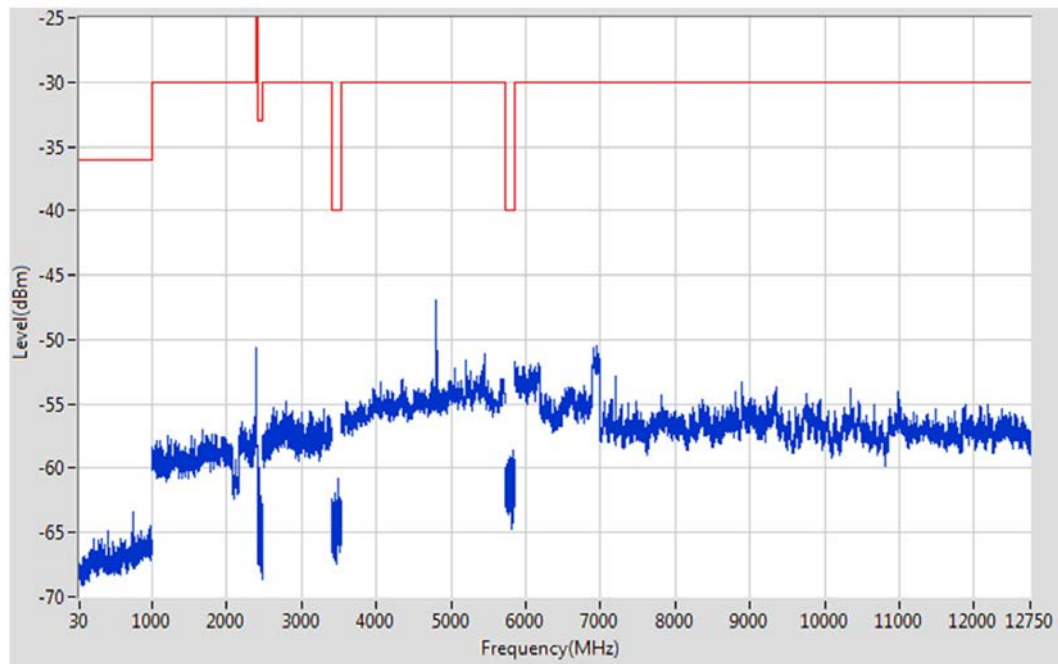

6.6 Collateral Emissions of Receiver

6.6.1 Measuring Parameter Settings

- Measurement Instrument Type: Spectrum Analyzer
- Test Mode: Receiver Mode
- Measuring Parameter: Peak amplitude value within all frequency bands
- HCI Test Commands SSCOM32 Strings: See Table 4-2 in *Section 4.4 Test Command Summary on page 17*
- Spectrum Analyzer Settings: Table 6-5 on page 32

The spectrum analyzer settings shall be the same as transmitter test described in *Section 6.5 Collateral Emissions of Transmitter on page 33* while performing such measurements at Ch0, Ch19 or Ch39 respectively.

6.6.2 Explanation of Test Result

Figure 6-5 shows an overall test plot while performing collateral emissions of transmitter at the highest channel of EUT. The peak amplitude level within each segment of frequency band shall be listed in test record for determining compliance with requirement above.

Figure 6-5: Example Test Plot of Collateral Emissions of Receiver

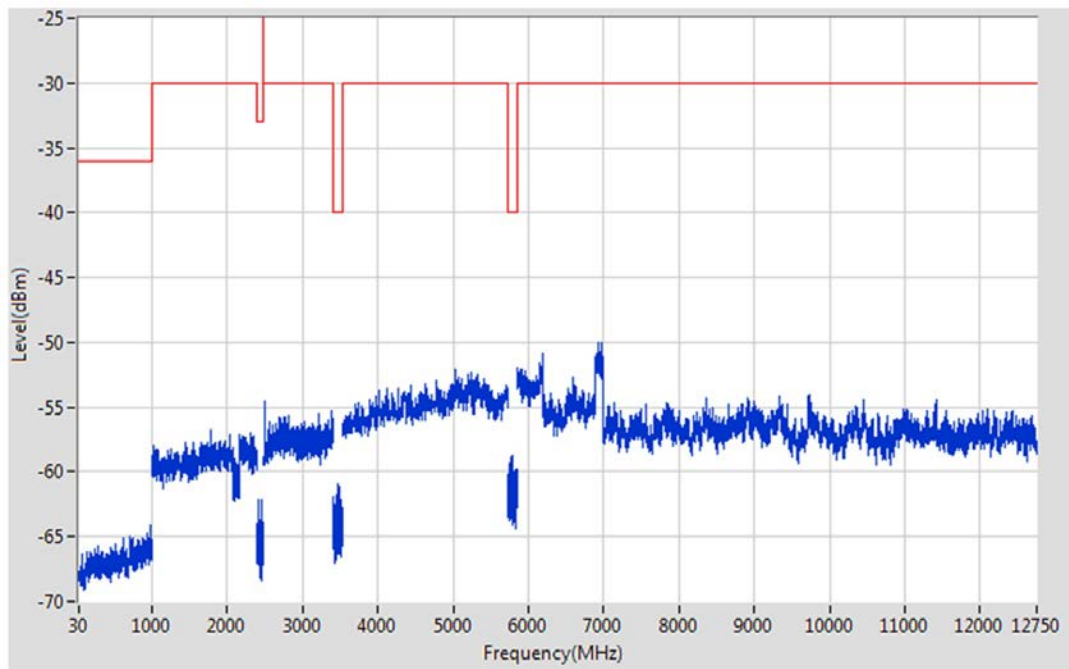

SECTION

7

FCC Compliance Test Guidance

7.1 Test Items and Requirements

Table 7-1: Applicable Standards for FCC Compliance Test

No.	Identity	Document Title
1	47 CFR Part 15 Subpart C	Miscellaneous Wireless Communication Services
2	FCC KDB 558074 D01 DTS Meas Guidance v05	Guidance for Performing Compliance Measurements on Digital Transmission Systems (DTS) Operating Under §15.247
3	ANSI C63.10-2013	American National Standard for Testing Unlicensed Wireless Devices

Table 7-2: FCC Compliance Test Items and Requirements

No.	Measurement Items	Limit	Channels for Testing	FCC Rule Section
1	Output Power	EIRP \leq 30dBm	Low/Mid/High	15.247(b)
2	Occupied Bandwidth	\geq 500 kHz	Low/Mid/High	15.247(a)
3	Conducted Spurious Emission	See Table 7-6 on page 42	Low/Mid/High	15.247(d)
4	Radiated Spurious Emission	See Table 7-9 on page 46	Low/Mid/High	15.209 15.247(d)
5	Band Edge	See Table 7-12 on page 51	Low/High	15.209 15.247(d)
6	Power Spectral Density	\leq 8 dBm/3kHz	Low/Mid/High	15.247(e)

7.2 EUT Configuration

According to ANSI C63.10, the number of fundamental frequencies to be tested shall be set to 3 for Bluetooth Low Energy devices operating within unlicensed 2400~2483.5 MHz ISM band: 2402 MHz, 2440 MHz and 2480MHz.

Furthermore, the unlicensed wireless device shall be configured to operate in continuous transmit mode (e.g., 100% duty cycle). For systems incapable of supporting 100% duty cycle, the unlicensed device shall be operated using the maximum possible duty cycle.

As defined in Table 4-2 on page 17, EUT with Apollo series Bluetooth Low Energy SoCs can be set to continuous transmit mode by following HCI test commands defined in Table 7-3 below.

Table 7-3: Transmitter Test Commands to Achieve 100% Duty Cycle

Packaged HCI Commands	Hexadecimal Strings	Description
HCI_LE_TRANSMITTER_TEST (Applicable for Apollo4 Blue)	01 1e 20 03 xx 25 11	'11' indicates sending continuously modulation signal.
HCI_LE_TRANSMITTER_TEST (Applicable for Apollo3 Blue)	01 1e 20 03 xx 25 09	'09' indicates sending continuously modulated signal.
HCI_EM_9304_TRANSMITTER_TEST (Applicable for Apollo2 Blue)	01 11 fc 04 01 xx 25 00	'01' indicates sending continuously modulated signal.

NOTE: 'xx' in hexadecimal strings above indicates channel to be tested, which the 3 typical low, middle and high channels can be represented by '0x00' (2402 MHz), '0x13' (2440 MHz) and '0x27' (2480 MHz) respectively.

The measurement procedures are based on the use of an antenna-port conducted test configuration. Antenna-port conducted measurements shall be performed using test equipment that matches the nominal impedance of the antenna assembly to be used with the EUT. Additional attenuation may be required in the conducted RF path to prevent overloading of the measurement instrument. The measured power levels shall be adjusted to account for all losses or gains introduced into the conducted RF path, including cable loss, external attenuation or amplification. For antenna-port conducted test, conducted value is equal to measurement value plus all losses.

However, if antenna-port conducted tests cannot be performed on EUT (e.g., portable or handheld devices with integrated PCB or chip antenna), then radiated tests are acceptable for demonstrating compliance to the conducted emission requirements.

7.3 Output Power

7.3.1 Limit Requirement

For systems using digital modulation techniques in the 2400~2483.5 MHz bands, the maximum peak conducted output power of the EUT shall not exceed: 30 dBm. As an alternative to a peak power measurement, compliance with the limit can be based on a measurement of the maximum conducted output power. Maximum Conducted Output Power is defined as the total transmit power delivered to all antennas and antenna elements averaged across all symbols in the signaling alphabet when the transmitter is operating at its maximum power control level. Power must be summed across all antennas and antenna elements.

7.3.2 Test Equipment Settings

This procedure shall be used when the spectrum analyzer has an available RBW that is greater than the DTS bandwidth (e.g., occupied bandwidth). Peak search function shall be used to determine the peak amplitude level until spectral trace is fully stabilized. The main instrumental parameter settings are shown in Table 7-4 below.

Table 7-4: Spectrum Analyzer Settings of Output Power Measurement

Setting Parameters of SA	Value
Center Frequency	2402 / 2440 / 2480 MHz
Span	3 MHz
RBW (Resolution Bandwidth)	1 MHz
VBW (Video Bandwidth)	3 MHz
Detector Mode	Peak
Sweep Time	Auto
Trace Mode	Max Hold

7.3.3 Explanation of Test Result

The following Figure 7-1 on page 40 shows a typical spectrum and related settings displayed on the screen of spectrum analyzer while performing the maximum peak conducted output power test per FCC standard. Note that the RBW should be greater than DTS bandwidth and the peak search function should be used to determine the maximum amplitude level until the trace fully stabilizes. In addition, the offset level shall be set in the spectrum analyzer to compensate the RF cable loss and attenuation between antenna port of EUT and RF input port of spectrum analyzer. With the offset compensation value, the reading level in spectrum analyzer is exactly equal to the maximum peak conducted output power of EUT.

Figure 7-1: Example Test Plot of Maximum Conducted Output Power

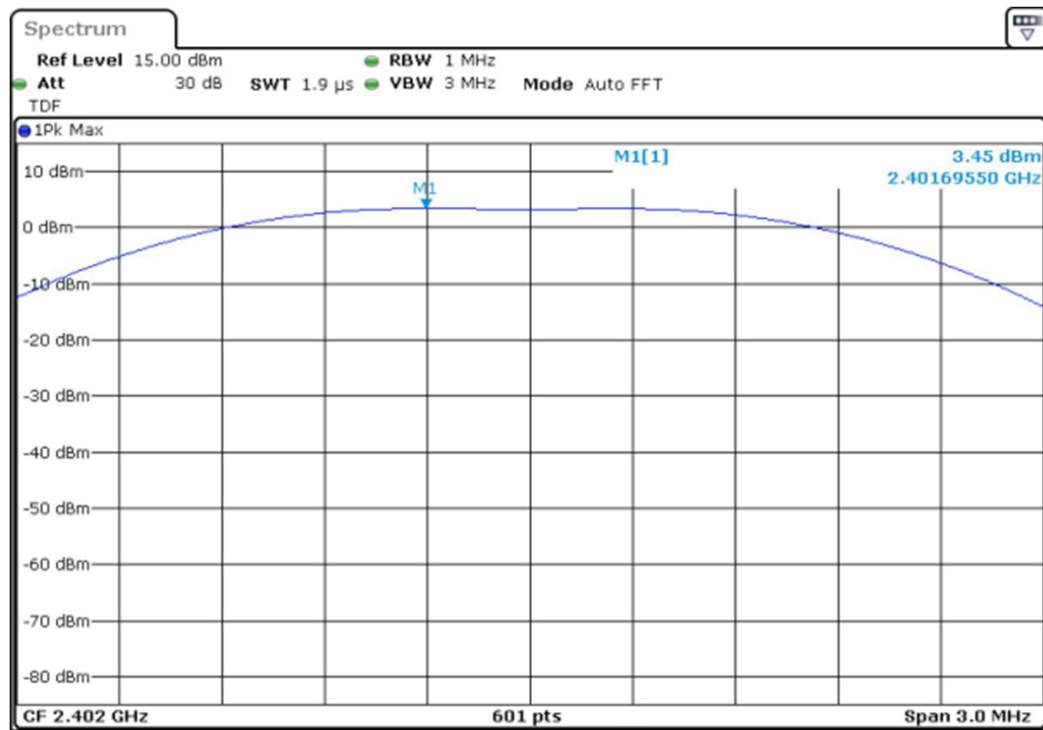

7.4 Occupied Bandwidth

7.4.1 Limit Requirement

The minimum 6 dB bandwidth of a DTS transmission shall be at least 500 kHz.

7.4.2 Test Equipment Settings

Table 7-5: Spectrum Analyzer Settings of Occupied Bandwidth Measurement

Setting Parameters of SA	Value
Center Frequency	2402 / 2440 / 2480 MHz
Span	3 MHz
RBW (Resolution Bandwidth)	100 MHz
VBW (Video Bandwidth)	300 MHz
Detector Mode	Peak
Sweep Time	Auto
Trace Mode	Max Hold

7.4.3 Explanation of Test Result

The following Figure 7-2 shows the trace and plot displayed in spectrum analyzer while performing occupied bandwidth test at center frequency 2402 MHz. Measure the maximum width of the emission that is constrained by the frequencies associated with the two outermost amplitude points (upper and lower frequencies) that are attenuated by 6 dB relative to the maximum level measured in the fundamental emission. Note that M2 in Figure 7-2 indicates the peak amplitude level of fundamental emission at 2402 MHz and M1 means the lower side marker point where the amplitude level is 6 dB lower than M2. Then the delta marker D1 can determine the 6-dB bandwidth by calculating X-value relative to marker M1 in frequency domain.

Figure 7-2: Example Test Plot of Occupied Bandwidth in Low Channel

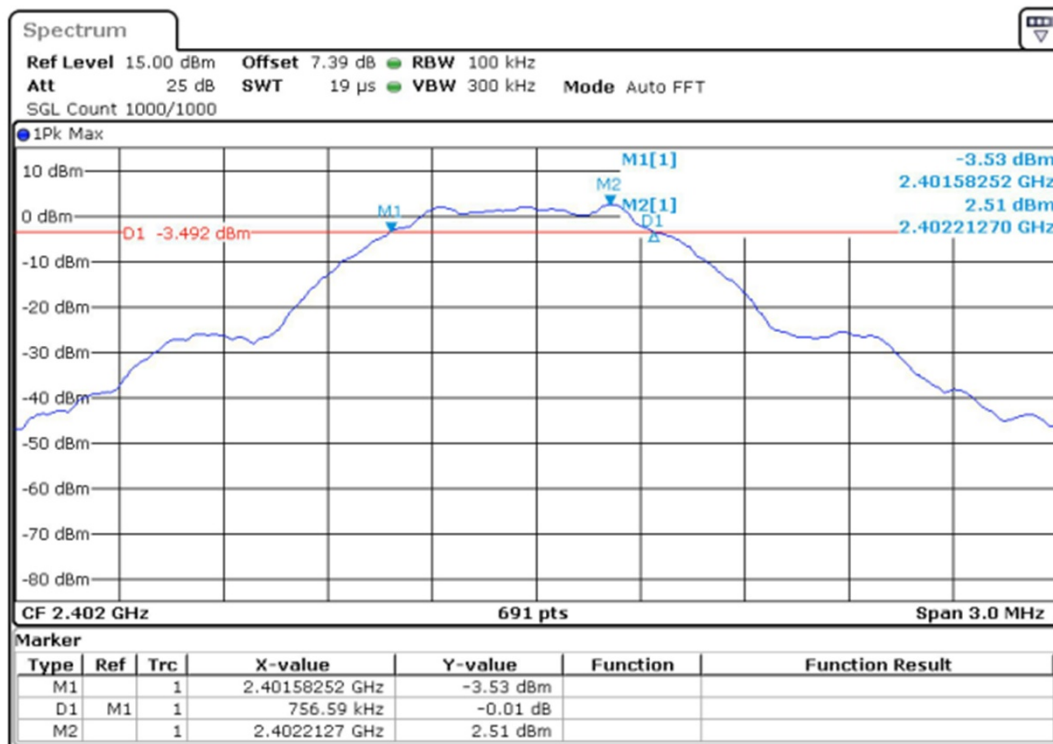

7.5 Conducted Spurious Emission

7.5.1 Limit Requirement

Conducted spurious emission here corresponds to emissions in nonrestricted frequency bands defined in ANSI C63.10. According to FCC section §15.247(d), in any 100 kHz bandwidth outside of the authorized frequency band, the power level shall be attenuated according to the following conditions:

1. If the maximum peak conducted output power procedure was used to determine compliance, then the peak output power measured in any 100 kHz bandwidth outside of the authorized frequency band shall be attenuated by at least 20 dB relative to the maximum in-band peak PSD level in 100 kHz (e.g., 20 dBc).
2. If the maximum average conducted output power procedure was used to determine compliance, then the peak power in any 100 kHz bandwidth outside of the authorized frequency band shall be attenuated by at least 30 dB relative to the maximum in-band peak PSD level in 100 kHz (e.g., 30 dBc).

The respective requirements corresponding to the above two conditions are given in Table 7-6 below. Generally, for the sake of consistency, only the test method of peak detector mode (e.g., the 1st item listed above) shall be utilized for practical application.

Table 7-6: Limit Requirement of Conducted Spurious Emission

Detector Function	Output Power Level at Fundamental Frequencies	Relative Limit (dBc)	Absolute Limit (dBm)
Peak	P_{peak}	20	$P_{peak} - 20$
RMS	P_{avg}	30	$P_{avg} - 30$

7.5.2 Test Procedure

The following procedures shall be used to determine compliance to these requirements listed in Table 7-6. Note that these procedures can be used in either an antenna-port conducted or a radiated test setup.

7.5.2.1 Fundamental Emission Level Measurement

Establish a reference level of fundamental emission by using the following procedure:

1. Set instrument center frequency to DTS channel center frequency.
2. Set the span to ≥ 1.5 times the DTS bandwidth.
3. Set the RBW = 100 kHz.
4. Set the VBW $\geq [3 \times \text{RBW}]$.

5. Detector = peak.
6. Sweep time = auto couple.
7. Trace mode = max hold.
8. Allow trace to fully stabilize.
9. Use the peak marker function to determine the maximum PSD level.

Note that the channel found to contain the maximum PSD level can be used to establish the reference level. See Table 7-7 on page 43 below for detailed instrumental parameter settings.

7.5.2.2 **Spurious Emission Level Measurement**

Establish a spurious emission level by using the following procedure:

1. Set the center frequency and span to encompass frequency range to be measured.
2. Set the RBW = 100 kHz.
3. Set the VBW $\geq [3 \times \text{RBW}]$.
4. Detector = peak.
5. Sweep time = auto couple.
6. Trace mode = max hold.
7. Allow trace to fully stabilize.
8. Use the peak marker function to determine the maximum amplitude level.

Ensure that the amplitude of all unwanted emissions outside of the authorized frequency band (excluding restricted frequency bands) is attenuated by at least the minimum requirements specified in *Section 7.5.1 Limit Requirement on page 42*.

Report the three highest emissions relative to the limit. See Table 7-8 on page 44 for detailed instrumental parameter settings.

7.5.3 **Test Equipment Settings**

Table 7-7: Spectrum Analyzer Settings of Reference Level Measurement

Setting Parameters of SA	Value
Center Frequency	2402 / 2440 / 2480 MHz
Span	3 MHz
RBW (Resolution Bandwidth)	100 kHz
VBW (Video Bandwidth)	300 kHz
Detector Mode	Peak
Sweep Time	Auto
Trace Mode	Max Hold

Table 7-8: Spectrum Analyzer Settings of Emission Level Measurement

Span	RBW (kHz)	VBW (kHz)	Sweep Mode	Sweep Time (ms)	Detector & Trace Mode	Limit (dBc)
30 MHz ~ 3 GHz	100	300	Auto	30	Peak	20
2 GHz ~ 25 GHz	100	300	Auto	230	Max Hold	20

7.5.4 Explanation of Test Result

The following Figure 7-3 shows the example test graph when performing conducted fundamental emission reference level measurement at center frequency 2480 MHz and the following Figure 7-4 and Figure 7-5 on page 45 show spurious emission level measurement from 30 MHz to 25 GHz employing a peak detector. Note that the M1 marker indicates the reference level of fundamental emission at 2480 MHz and the corresponding reading value in the plot is 2 dBm in Figure 7-3. Thus, when running succeeding spurious emission measurement within nonrestricted frequency bands from 30 MHz to 25 GHz outside the EUT operating frequency band, the absolute limit line D1 in Y-axis is set as -18 dBm (equal to 20 dBc attenuation relative to reference level) for determining compliance to requirements in Figure 7-4 and Figure 7-5 on page 45.

Figure 7-3: Example Test Plot of Fundamental Emission in High Channel

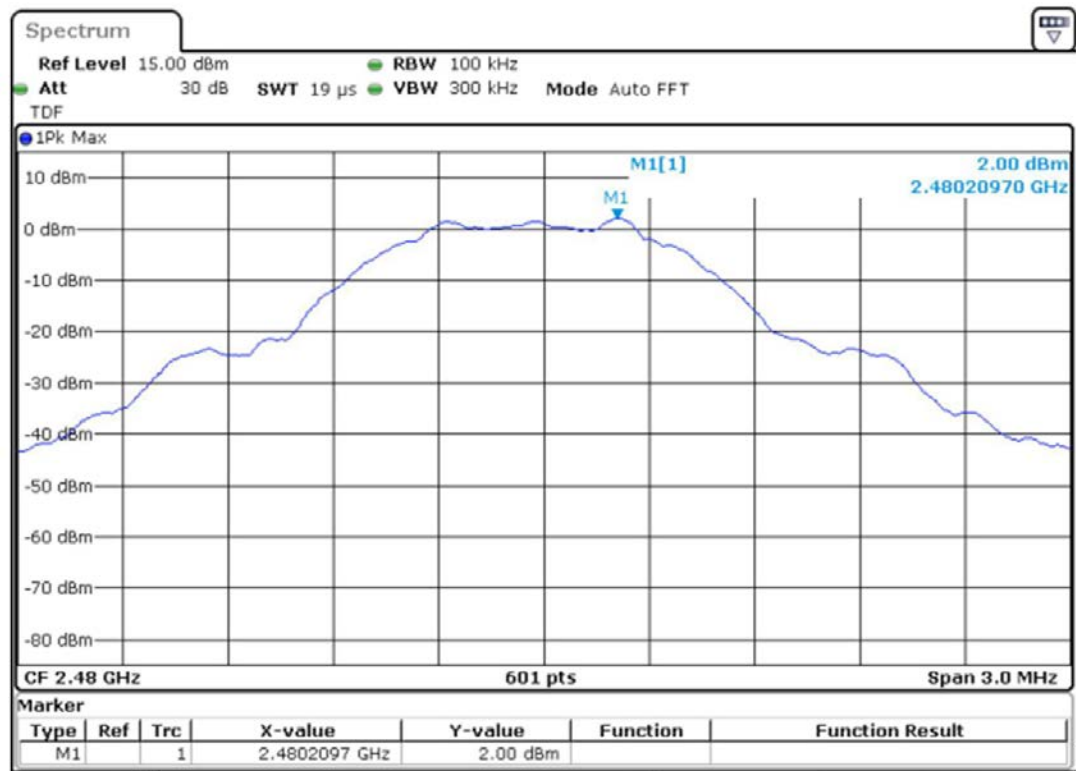

Figure 7-4: Example of Conducted Spurious Emission Test for 30 MHz to 3 GHz

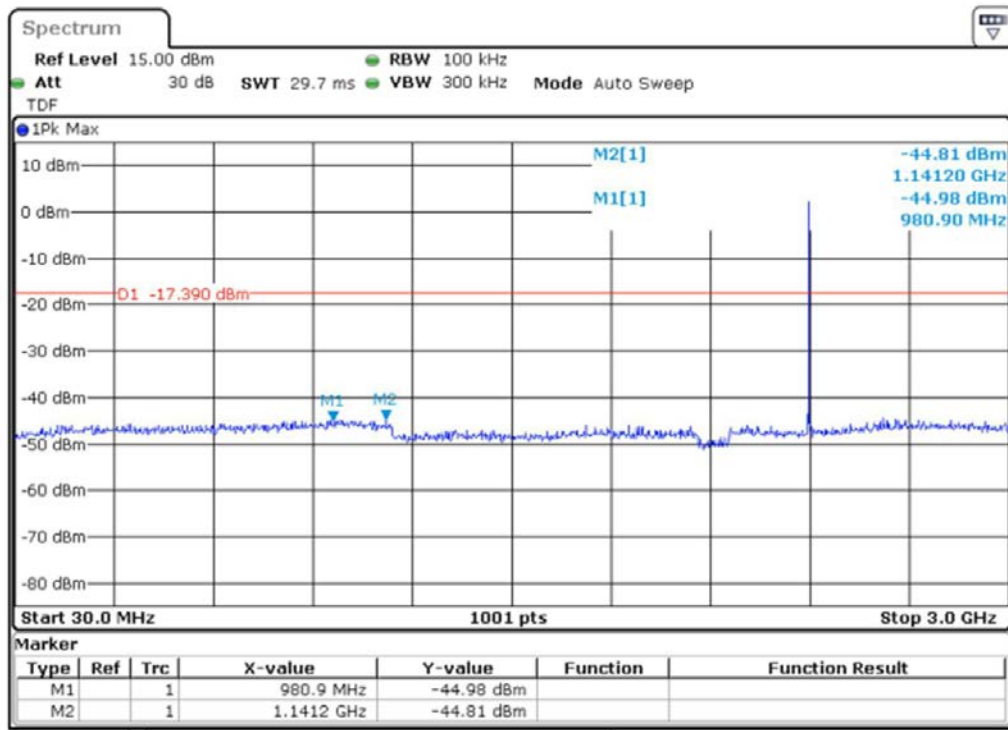
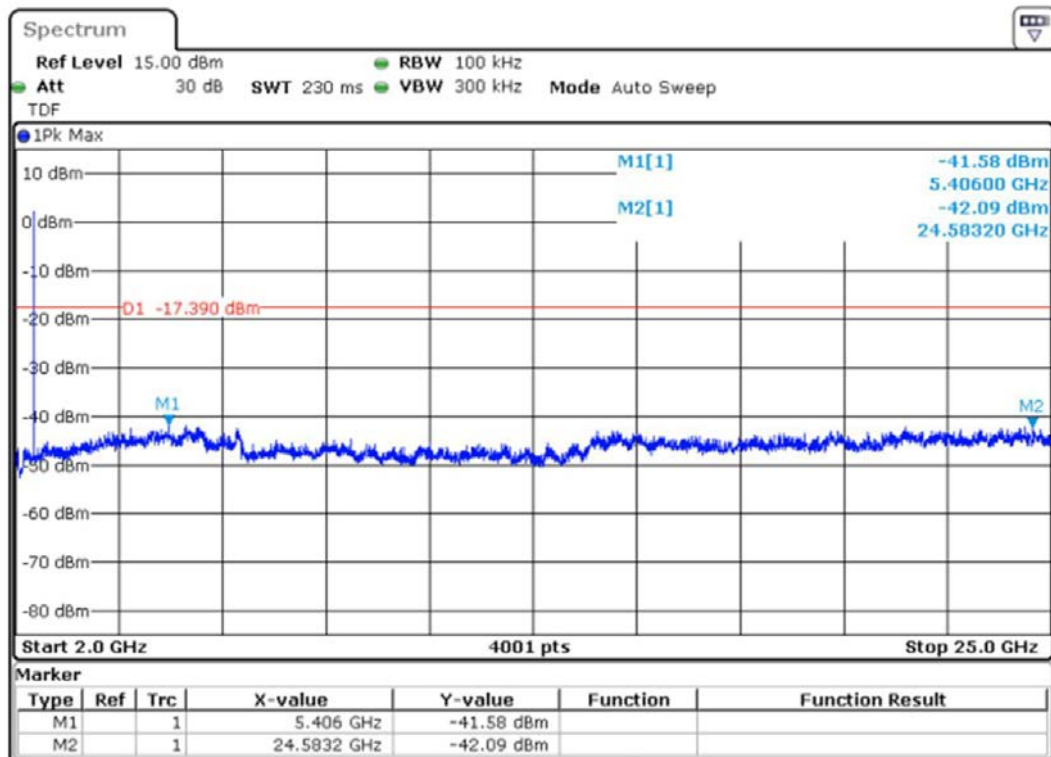

Figure 7-5: Example of Conducted Spurious Emission Test for 2 to 25 GHz



7.6 Radiated Spurious Emission

7.6.1 Limit Requirement

Radiated spurious emission here corresponds to emissions in restricted frequency bands defined in ANSI C63.10. According to FCC section §15.205 and §15.209(a), the emissions from EUT shall not exceed the field strength levels specified in the Table 7-9:

Table 7-9: The Requirements for Radiated Emission

No.	Frequency Band (MHz)	Field Strength ($\mu\text{V}/\text{m}$)	Field Strength ($\text{dB}\mu\text{V}/\text{m}$)	Detector Mode	Distance (m)
1	30-88	100	40	Quasi-Peak	3
2	88-216	150	43.5		
3	216-960	200	46		
4	above 960	500	54		
5	1000~18000	See Table 7-10			

NOTES:

- Field Strength ($\text{dB}\mu\text{V}/\text{m}$) = $20 \cdot \log$ [Field Strength ($\mu\text{V}/\text{m}$)].
- In the emission table above, the tighter limit shall apply at each band edges.
- At frequencies less than or equal to 1000 MHz, compliance with the emission limits in Table 7-9 shall be demonstrated using measurement instrumentation employing a CISPR quasi-peak detector specified in CISPR 16-1-1: 2010.
- At frequencies above 1000 MHz, compliance with the emission limits in Table 7-9 shall be demonstrated based on measuring instrumentation employing an average detector. However, if measurement employing a peak detector is performed, 20 dB above the maximum permitted average limit of field strength specified in Table 7-9 shall apply, see Table 7-10 below for details.

Table 7-10: The Requirements for Radiated Emission Above 1 GHz

Frequency Band	Director Mode	Field Strength ($\mu\text{V}/\text{m}$)	Field Strength ($\text{dB}\mu\text{V}/\text{m}$)
1~18 GHz	Average	500	54
	Peak	5000	74

7.6.2 Test Setup

The radiated emissions shall be measured using Quasi-Peak Detector (30MHz~1GHz) in semi-anechoic chamber and average/peak detector (above 1GHz) in full anechoic chamber. The maximal emission value is acquired by adjusting the antenna height, polarisation and turntable azimuth in accordance with the test software setup.

Normally, the height range of antenna is 1m to 4m and the azimuth range of turntable is 0° to 360°. The receiving antennas shall be used with two different forms: bi-log antenna for 30 MHz to 1 GHz, horn antenna for above 1 GHz. And both of the two antenna forms should have two polarizations: *Vertical* and *Horizontal*.

EUT shall be configured in continuous transmit mode (duty cycle = 100%) hence the test is considered to perform at worst emission state.

- Measurement bandwidth (RBW) for 30 MHz to 1000 MHz shall be set to 100 kHz.
- Measurement bandwidth (RBW) for 1 GHz to 18 GHz shall be set to 1 MHz.

The following Figure 7-6 shows the block diagram of semi-anechoic chamber setup for radiated emissions below 1 GHz, where a biconical logarithmic-periodic antenna applies; and the following Figure 7-7 on page 48 shows the block diagram of full anechoic chamber setup for radiated emissions above 1 GHz, where a double-ridged waveguide horn antenna applies.

Figure 7-6: Test Configuration of Radiated Emission Below 1 GHz

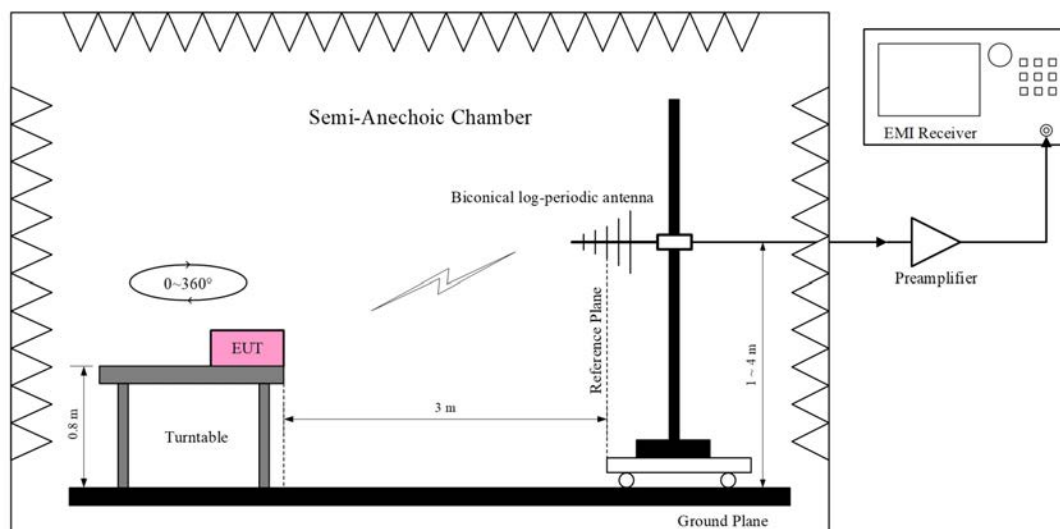
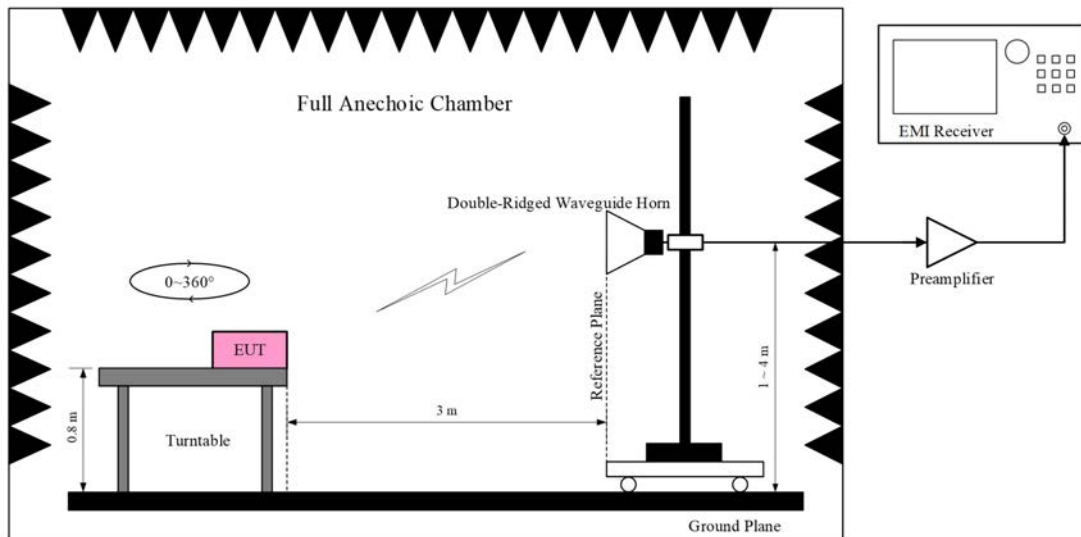

Figure 7-7: Test Configuration of Radiated Emissions Above 1 GHz



7.6.3 Test Procedure

Since radiated measurements require specialized test environment as specified in *Section 7.6.2 Test Setup on page 47* and usually only Third-party authorized test labs are qualified for these tests, it's difficult to perform pre-tests and rectifications in-house during product development without paying certain price. Then antenna-port conducted measurements may be used as an alternative to radiated measurements for determining compliance in the restricted frequency bands requirements. If antenna-port conducted measurements are performed, then proper impedance matching in antenna port must be ensured.

The general procedure for conducted measurements in restricted bands is as follows:

1. Measure the conducted output power (in dBm) of spurious emissions using the detector specified in Table 7-9 on page 46 respectively.
2. Add the maximum transmit antenna gain (in dBi) to the measured emission power level to determine the EIRP.
3. Add the appropriate maximum ground reflection factor to the EIRP (6 dB for frequencies ≤ 30 MHz; 4.7 dB for frequencies between 30 MHz and 1000 MHz, inclusive; and 0 dB for frequencies > 1000 MHz).
4. Convert the resultant EIRP to an equivalent electric field strength using the following relationship:

$$E = \text{EIRP} - 20 \log d + 104.8$$

where

E is the electric field strength in dB μ V/m

EIRP is the equivalent isotropically radiated power in dBm

d is the specified measurement distance in m

5. Compare the resultant electric field strength level with the limit defined in Table 7-9 on page 46.

An additional consideration when performing conducted measurements of restricted-band emissions is that unwanted emissions radiating from the EUT cabinet/case, control circuits, power leads, or intermediate circuit elements will likely go undetected in a conducted measurement configuration. To address this concern, an additional radiated test shall be performed to ensure that emissions emanating from the EUT cabinet/case (rather than from the antenna port) also comply with the applicable limits.

For these cabinet/case radiated spurious emission measurements, the EUT transmit antenna may be replaced with a termination matching the nominal impedance of the antenna. Procedures for performing radiated measurements are specified in ANSI C63.10. All detected emissions shall comply with the applicable requirements.

7.6.4 Test Equipment Settings

Table 7-11: Spectrum Analyzer Settings of Occupied Bandwidth Measurement

Setting Parameters of SA	Value
Span	See frequency range defined in Table 7-9 on page 46
RBW (Resolution Bandwidth)	100 kHz for below 1 GHz and 1 MHz for above 1 GHz
VBW (Video Bandwidth)	$\geq [3 \times \text{RBW}]$
Detector Function	See Table 7-9 and Table 7-10 on page 46 for reference
Sweep Time	Auto
Trace Mode	Max Hold

7.6.5 Explanation of Test Result

Figure 7-8: Radiated Emission Test Plot for 30 MHz to 1 GHz

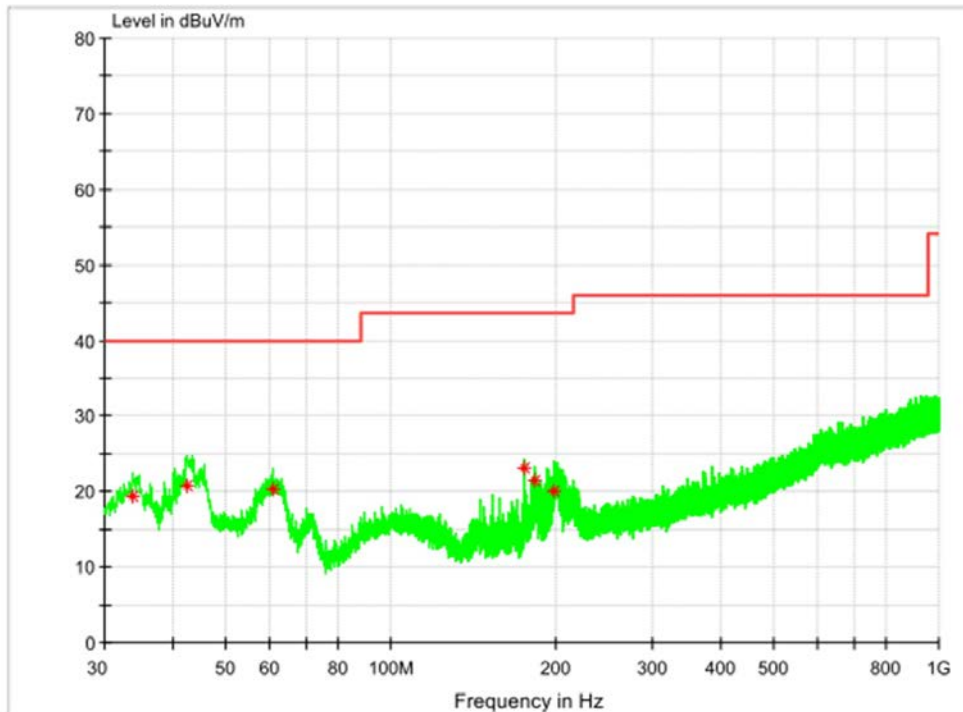

Figure 7-9: Radiated Emission Test Plot for Above 1 GHz

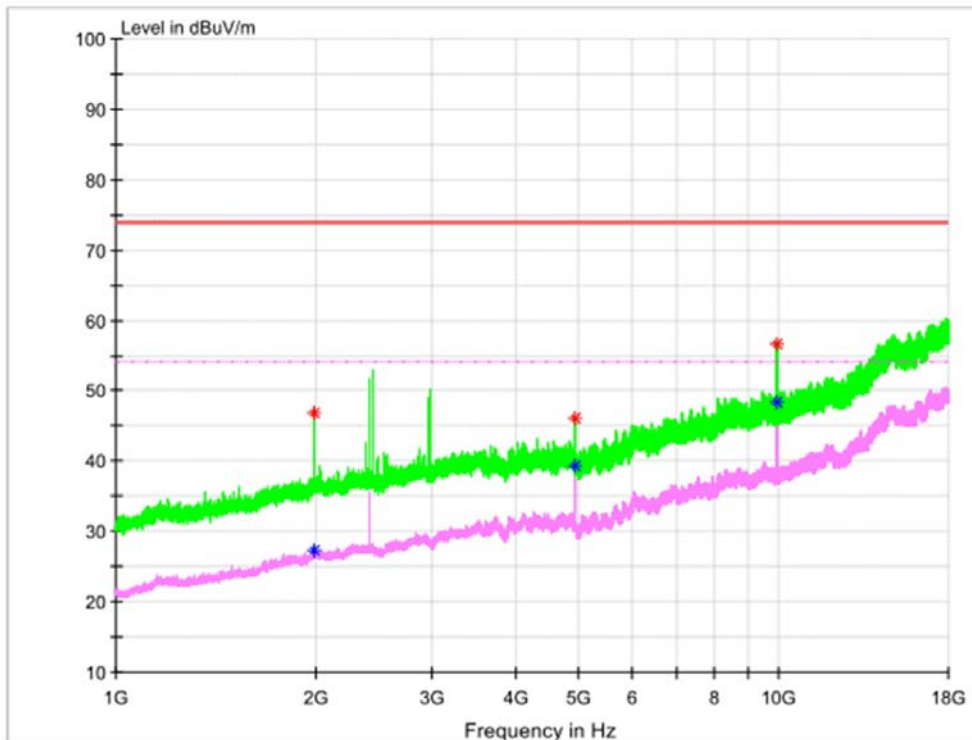

Figure 7-8 on page 50 shows an example of radiated emission test employing quasi-peak detector below 1 GHz, and Figure 7-9 on page 50 shows an example of radiated emission test employing average and peak detector above 1 GHz. Note that the pink trace indicates measurement using average detector as well as the green trace indicates measurement using peak detector in Figure 7-9. The final reading values are both given by field strength in units of dB μ V/m.

Furthermore, if the peak-detected amplitude can be shown to comply with the average limit, then it is not necessary to perform a separate average-detected measurement.

7.7 Band Edge

7.7.1 Limit Requirement

Band edge testing means the unwanted emissions shall be tested at the edge of operating frequency band when EUT is transmitting in the lowest or highest channel respectively, e.g., emissions measurement at 2400 MHz or 2483.5 MHz for Bluetooth devices.

Table 7-12: Limit Requirement of Band Edge Testing

Operating Channel	Emission Frequency to be Measured	1 MHz Integral Interval of Band Power	Measurement Bandwidth	Absolute Limit (dBm)
2402 MHz	2400 MHz	2400 \pm 0.5 MHz	100 kHz	$P_o - 20$
2480 MHz	2483.5 MHz	2483.5 \pm 0.5 MHz		

NOTE: P_o indicates the desired output power level of fundamental emission in low/high channel.

According to FCC section §15.247(d), in any 100 kHz measurement bandwidth outside the operating frequency band, the radio frequency power that is produced by the EUT shall be at least 20 dB below that in the same 100 kHz measurement bandwidth within the frequency band that contains the highest level of the desired power, based on either an RF conducted or a radiated measurement, provided the transmitter demonstrates compliance with the peak conducted power limits. The detailed requirements are given in Table 7-12 above.

7.7.2 Test Procedure

1. Measure the reference level of fundamental emission in lowest/highest channel, refer to *Section 7.5.2.1 Fundamental Emission Level Measurement on page 42* for test procedure and see Table 7-13 for instrument settings.
2. Measure unwanted emissions at or near the band edge (within 2 MHz of the authorized band), the following integration procedure shall be used:
 - a. Set center frequency to the frequency of the emission to be measured (must be within 2 MHz of the authorized band edge).
 - b. Set span to 2 MHz.
 - c. RBW = 100 kHz.
 - d. VBW $\geq [3 \times \text{RBW}]$.
 - e. Detector = peak.
 - f. Sweep time = auto.
 - g. Trace mode = max hold.
 - h. Allow sweep to continue until the trace stabilizes.
 - i. Compute the power by integrating the spectrum over 1 MHz using the spectrum analyzer's band power measurement function with band limits set equal to the emission frequency ($f_{\text{emission}} \pm 0.5 \text{ MHz}$).
 - j. If the instrument does not have a band power function, then sum the amplitude levels (in power units) at 100 kHz intervals extending across the 1 MHz spectrum defined by $f_{\text{emission}} \pm 0.5 \text{ MHz}$.

See Table 7-14 on page 53 for instrument settings when performing lower / upper band edge testing.

7.7.3 Test Equipment Settings

Table 7-13: Spectrum Analyzer Settings of Reference Level Measurement

Setting Parameters of SA	Values
Center Frequency	2402 / 2480 MHz
Span	3 MHz
RBW (Resolution Bandwidth)	100 kHz
VBW (Video Bandwidth)	300 kHz
Detector Mode	Peak
Sweep Time	Auto
Trace Mode	Max Hold

Table 7-14: Spectrum Analyzer Settings of Band Edge Measurement

Setting Parameters of SA	Values
Center Frequency	2400 / 2483.5 MHz
Span	2 MHz
RBW (Resolution Bandwidth)	100 kHz
VBW (Video Bandwidth)	300 kHz
Detector Mode	Peak
Sweep Time	Auto
Trace Mode	Max Hold
Measurement Function	Band power integral over 1 MHz ($f_{\text{emission}} \pm 0.5$ MHz)

7.7.4 Explanation of Test Result

The following Figure 7-10 shows an example graph of fundamental emission test in the lowest channel (2402 MHz) and the corresponding reference power level measured by instrument is 2.61 dBm. Thus, the absolute limit of lower band edge emission testing can be set to -17.39 dBm. The following Figure 7-11 on page 54 shows band power by integrating the spectrum over 1 MHz interval. In Figure 7-11, the integral interval is set to the emission frequency ± 0.5 MHz and the final integral value is -37.54 dBm computed by spectrum analyzer's band power measurement function automatically. Note that the band power integrated within $f_{\text{emission}} \pm 0.5$ MHz interval differs greatly from the direct measured power level at center frequency 2402 MHz where the reading value of marker M1 is -47.40 dBm on instrument display in Figure 7-11.

Figure 7-10: Reference Level of Fundamental Emission Testing in Low Channel

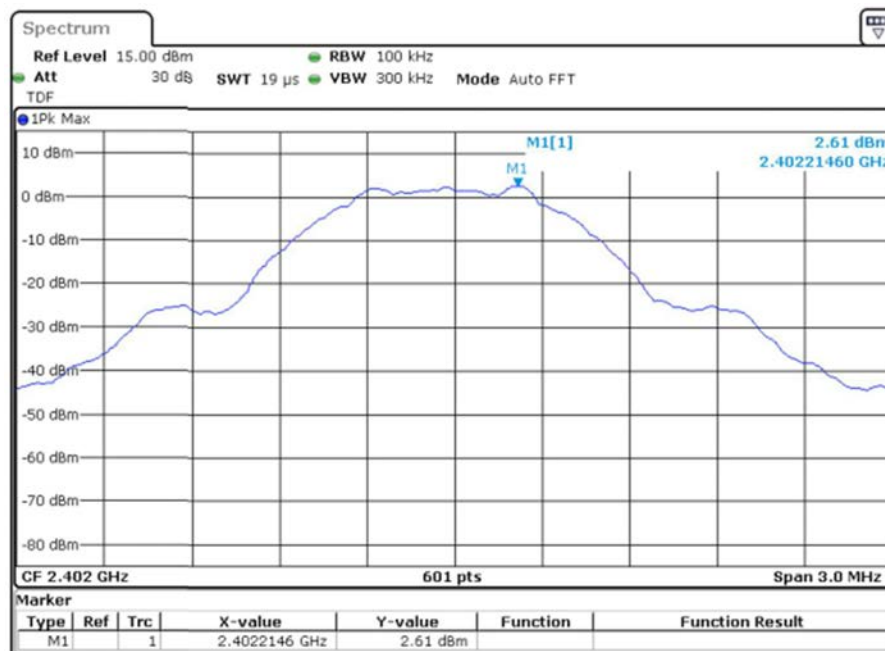
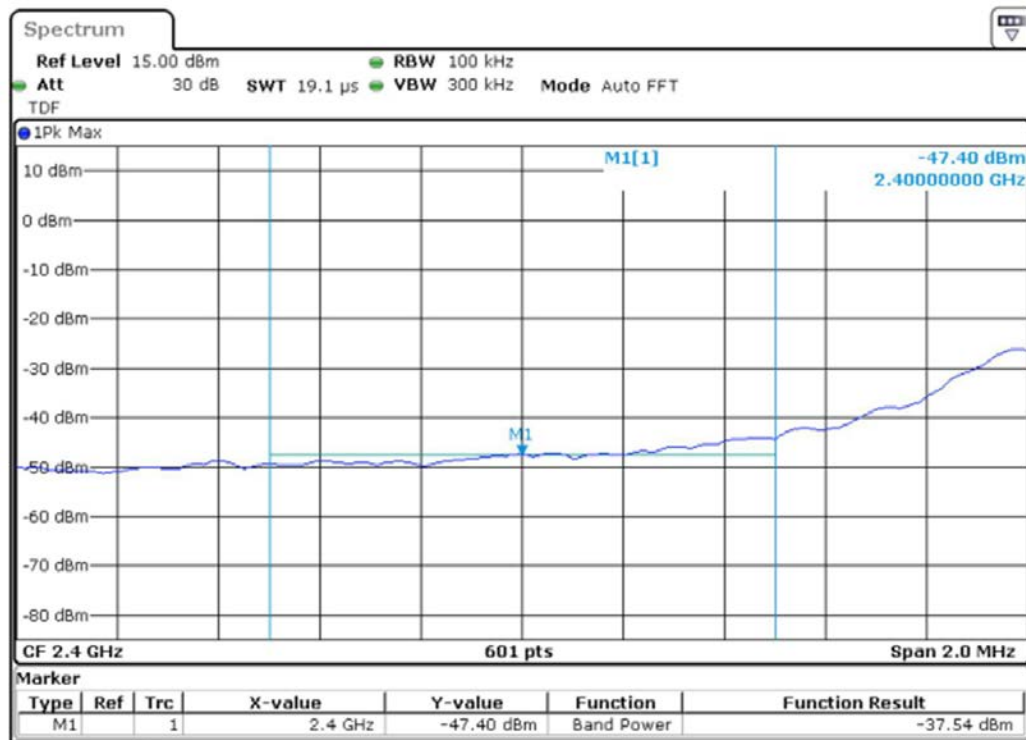

Figure 7-11: Band Power Integral Over 1 MHz Relative to Emission Frequency



7.8 Power Spectral Density

7.8.1 Limit Requirement

According to FCC section §15.247(e), the power spectral density conducted from the EUT to the antenna shall not be greater than 8 dBm in any 3 kHz measurement bandwidth during any time interval of continuous transmission. The same method of determining the conducted output power shall be used to determine the power spectral density.

7.8.2 Test Procedure

The following procedure shall be used if maximum peak conducted output power was used to determine compliance:

1. Set center frequency to EUT channel center frequency.
2. Set the span to 1.5 times the DTS bandwidth.
3. Set the RBW to $3 \text{ kHz} \leq \text{RBW} \leq 100 \text{ kHz}$.
4. Set the VBW $\geq [3 \times \text{RBW}]$.
5. Detector = peak.
6. Sweep time = auto couple.

7. Trace mode = max hold.
8. Allow trace to fully stabilize.
9. Use the peak search marker function to determine the maximum amplitude level within the RBW.
10. If measured value exceeds requirement, then reduce RBW (but no less than 3 kHz) and repeat.

7.8.3 Test Equipment Settings

Table 7-15: Spectrum Analyzer Settings of PSD Measurement

Setting Parameters of SA	Values
Center Frequency	2402 / 2440 / 2480 MHz
Span	1.5 MHz
RBW (Resolution Bandwidth)	3 kHz
VBW (Video Bandwidth)	10 kHz
Detector Mode	Peak
Sweep Time	Auto
Trace Mode	Max Hold

7.8.4 Explanation of Test Result

The following Figure 7-12 shows an example of power spectral density measurement using peak detector in middle channel (2440 MHz). The peak search function is used to find and mark the maximum peak amplitude level in test plot.

Figure 7-12: Example Test Plot of Power Spectral Density in Mid Channel

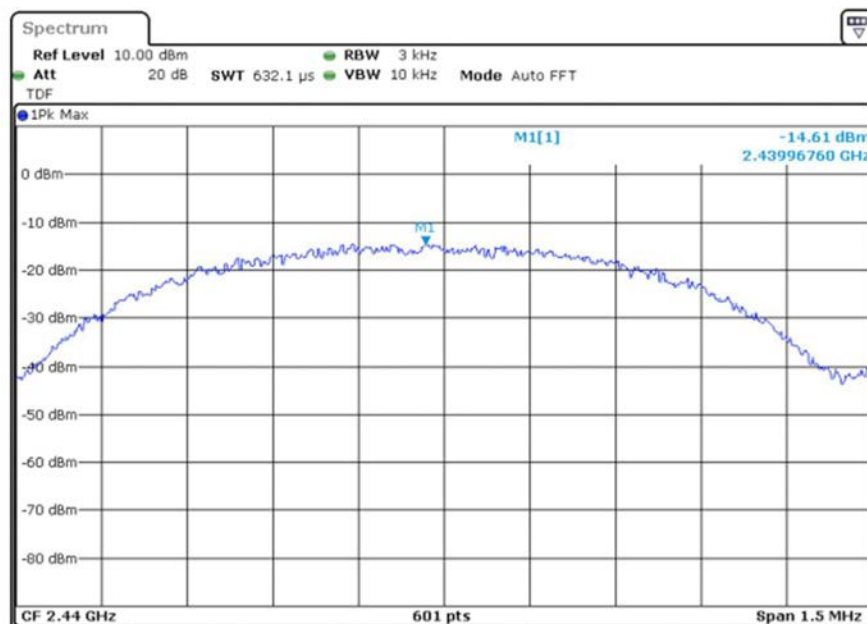

SECTION

8

CE Conformance Test Guidance

8.1 Test Items and Requirements

Table 8-1: Applicable Standards for CE Conformance Test

No.	Identify	Document Title
1	ETSI EN 300 328 V2.1.1	Wideband transmission systems; Data transmission equipment operating in the 2.4 GHz ISM band and using wideband modulation techniques; Harmonised Standard covering the essential requirements of article 3.2 of Directive 2014/53/EU
2	ETSI EN 300 440 V2.1.1	Short Range Devices (SRD); Radio equipment to be used in the 1 GHz to 40 GHz frequency range; Harmonised Standard covering the essential requirements of article 3.2 of Directive 2014/53/EU

Table 8-2: Test Items and Requirements

No.	Items	Limit Requirements	Channel for Testing	Test Mode
1	RF Output Power	EIRP \leq 20dBm	Low/Mid/High	Continuous TX
2	Power Spectral Density	\leq 10 dBm/MHz	Low/Mid/High	Continuous TX
3	Occupied Channel Bandwidth	lower and upper band edge must be within 2400~2483.5 MHz frequency band	Low/High	Continuous TX
4	Transmitter unwanted emissions in the out-of-band domain	See Figure 8-4 on page 62	Low/High	Continuous TX
5	Transmitter unwanted emissions in the spurious domain	See Table 8-10 on page 64	Low/High	Continuous TX
6	Receiver spurious emissions	Table 8-13 on page 66	Low/High	Receiver Mode
7	Receiver Blocking	Table 8-14 on page 67	Low/High	Receiver Mode

8.2 EUT Configuration

Unless otherwise specified, the measurements shall be performed using normal operation with EUT operating with the worst-case configuration (for example modulation, bandwidth, data rate, power, duty cycle) with regards to the requirement to be tested. For each of the requirements in the present document, this worst-case configuration shall be declared by the manufacturer and documented in the test report. Special software may be used to operate EUT in this mode. For example, there is a snapshot in one test report provided by third-party authorized lab in Figure 8-1 below, where special software that can operate EUT in worst transmission case must be declared.

Figure 8-1: Example Declaration of Special Software Used in Test Report

Bluetooth Low Energy

EUT Software Settings:

Mode	<input checked="" type="checkbox"/> Special software is used. The software provided by client to enable the EUT under transmission condition continuously at specific channel frequencies individually.
------	--

Regarding EUT embedded with Apollo series Bluetooth Low Energy SoCs, it can be configured to worst transmission state (i.e., continuous transmit mode) by sending HCI test commands via PC software or SSCOM32 tool defined in Table 8-3 below. For receiver parameter test, the command defined in Table 8-4 shall be used to configure EUT in receiver mode.

Table 8-3: HCI Test Commands for Transmission to Achieve 100% Duty Cycle

Packaged HCI Commands	Hexadecimal Strings	Description
HCI_LE_TRANSMITTER_TEST (Applicable for Apollo4 Blue)	01 1e 20 03 xx 25 11	'11' indicates sending continuously modulated signal.
HCI_LE_TRANSMITTER_TEST (Applicable for Apollo3 Blue)	01 1e 20 03 xx 25 09	'09' indicates sending continuously modulated signal.
HCI_EM_9304_TRANSMITTER_TEST (Applicable for Apollo2 Blue)	01 11 fc 04 01 xx 25 00	'01' indicates sending continuously modulated signal.

Table 8-4: HCI Test Command for Receiver Parametric Test

Packaged HCI Commands	Hexadecimal Strings	Description
HCI_LE_RECEIVER_TEST (Applicable for Apollo4 Blue in LE2M mode)	01 33 20 03 xx 02 00	Set EUT in LE2M RX test mode
HCI_LE_RECEIVER_TEST (Applicable for Apollo4/3/2 Blue in LE1M mode)	01 1d 20 01 xx	Set EUT in LE1M RX test mode

NOTE: "xx" in hexadecimal strings above indicates channel to be tested.

8.3 RF Output Power

8.3.1 Definition and Limit

The RF output power is defined as the mean equivalent isotropically radiated power (e.i.r.p.) of the equipment during a transmission burst. The maximum RF output power for EUT shall be equal to or less than 20 dBm. This limit shall apply for any combination of power level and intended antenna assembly.

8.3.2 Test Equipment Settings

The measurements for RF output power shall be performed at both normal environmental conditions and at the extremes of the operating temperature range. The EUT shall be operated under its worst-case configuration (e.g., continuous transmit mode, 100% duty cycle as above) with regards to the requirement being tested. The measurement shall be performed at the lowest, the middle, and the highest channel on which the equipment can operate.

Conducted measurement shall be used for RF output power and the EUT shall be connected to the spectrum analyzer via RF cable directly. This method assumes the spectrum analyser is equipped with the Time Domain Power option. Use the following settings and procedures for RF output power testing:

Table 8-5: Spectrum Analyzer Settings for RF Output Power

Measuring Parameter	Value
Center Frequency	The center frequency of the channel under test
Frequency Span	Zero Span
RBW (Resolution Bandwidth)	3 MHz
VBW (Video Bandwidth)	3 MHz
Detector Mode	Peak
Trace Mode	Max Hold
Sweep Time	Auto
Trigger Mode	RF (trigger on rising edge)

NOTE: The final EIRP = measuring conducted power level + EUT's antenna gain.

8.3.3 Explanation of Test Result

Figure 8-2: Example Test Plot of RF Output Power at Middle Channel

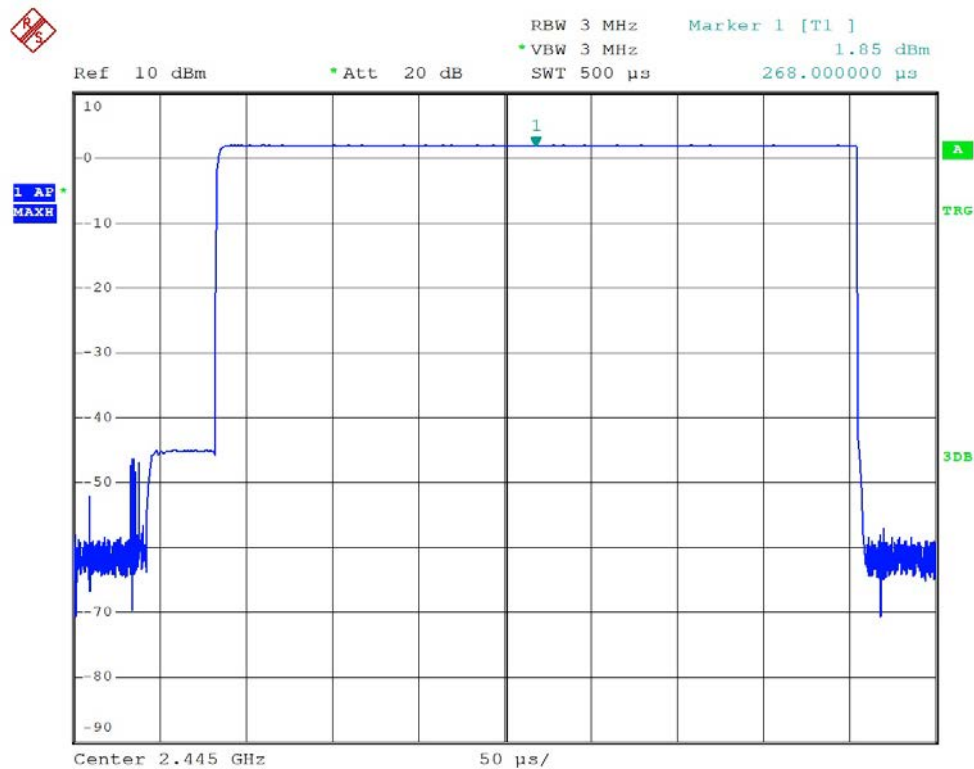

Figure 8-2 shows an example of spectrum on the screen when performing RF output power test at 2440 MHz with the method of time domain power function. The spectrum shape in Figure 8-2 is approximated equivalent to a square wave while the duty cycle of transmission is less than 100%. If continuous transmit mode is enabled, there will be a straight horizontal line appearing on spectrum analyzer's display.

8.4 Power Spectral Density

8.4.1 Definition and Limit

The Power Spectral Density (PSD) is the mean equivalent isotropically radiated power (e.i.r.p.) spectral density in a 1 MHz bandwidth during a transmission burst. For equipment using wide band modulations other than FHSS, the maximum Power Spectral Density is limited to 10 dBm/MHz. Note that the power spectral density is expressed by EIRP which shall take antenna gain into account.

8.4.2 Test Equipment Settings

The measurement shall only be performed at normal test conditions and repeated for the EUT being configured to continuous transmission mode operating at the lowest, the middle, and the highest frequency of the stated frequency range. For the duration of each test, the equipment shall not change its operating frequency. The spectrum analyzer settings are shown in Table 8-6 below.

Table 8-6: Spectrum Analyzer Settings for Power Spectral Density

Measuring Parameter	Value
Start Frequency	2400 MHz
Stop Frequency	2483.5 MHz
RBW (Resolution Bandwidth)	10 kHz
VBW (Video Bandwidth)	30 kHz
Detector Mode	RMS
Trace Mode	Max Hold
Sweep Points	> 8350
Sweep Time	10 s

8.5 Occupied Channel Bandwidth

8.5.1 Definition and Limit

The Occupied Channel Bandwidth is the bandwidth that contains 99 % of the power of the signal, also known as 99% power bandwidth. The Occupied Channel Bandwidth shall fall completely within the 2400~2483.5 MHz band whichever at lowest or highest channel, which means the lower band edge of it at the lowest frequency should be greater than 2400 MHz as well as the upper band edge of it at the highest frequency should be less than 2483.5 MHz.

8.5.2 Test Procedure

The measurement shall only be performed at normal test conditions and performed only on the lowest and the highest frequency within the stated frequency range.

The conducted measurement procedure shall be as follows:

1. Connect the EUT to the spectrum analyzer and use the following settings in Table 8-7 on page 61.

Table 8-7: Spectrum Analyzer Settings for Occupied Channel Bandwidth

Measuring Parameter	Value
Center Frequency	The center frequency of the channel under test
Span	2 MHz
RBW (Resolution Bandwidth)	100 kHz
VBW (Video Bandwidth)	300 kHz
Filter Type	Channel filter
Detector Mode	RMS
Trace Mode	Max Hold
Sweep Time	1 s

2. Wait for the trace to stabilize. Find the peak value of the trace and place the spectrum analyzer marker on this peak.
3. Use the 99% power bandwidth function of the spectrum analyser to measure the Occupied Channel Bandwidth of the EUT. Make sure that the power envelope is sufficiently above the noise floor of the analyser to avoid the noise signals left and right from the power envelope being taken into account by this measurement.

8.5.3 Explanation of Test Result

Figure 8-3: Example Test Plot of Occupied Channel Bandwidth of 2402 MHz

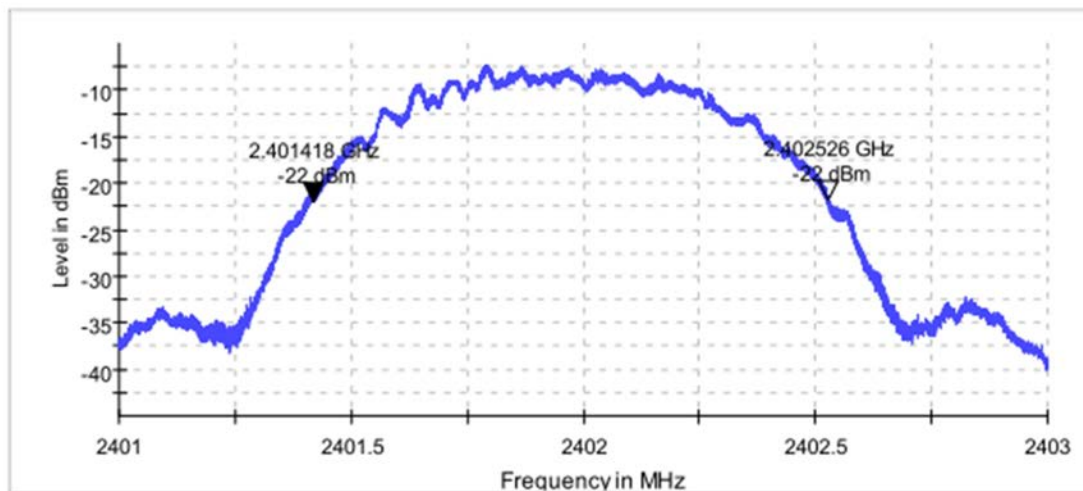

There is a typical GFSK spectrum on instrument display when performing conducted measurements at the lowest channel shown in Figure 8-3 above. The occupied channel bandwidth is determined and calculated by the lower and upper marker on the spectrum trace where 99% power bandwidth function was used.

Note that the marker value of lower side is 2401.418 MHz and the related occupied channel bandwidth is 1.108 MHz in Figure 8-3 on page 61. Thus, the lower band edge at the lowest frequency is greater than 2400 MHz and the test result can also be judged as compliance with requirement defined in *Section 8.5.1 Definition and Limit on page 60*.

8.6 Transmitter Unwanted Emissions in the Out-of-Band Domain

8.6.1 Definition and Limit

Transmitter unwanted emissions in the out-of-band domain are emissions when the EUT is in transmit mode, on frequencies immediately outside the necessary bandwidth which results from the modulation process, but excluding spurious emissions.

The transmitter unwanted emissions in the out-of-band domain but outside the allocated band, shall not exceed the values provided by the mask in Figure 8-4. Within the 2.4 GHz ISM band, the Out-of-band emissions are fulfilled by compliance with the Occupied Channel Bandwidth requirement in *Section 8.5 Occupied Channel Bandwidth on page 60*.

Figure 8-4: Transmit Mask

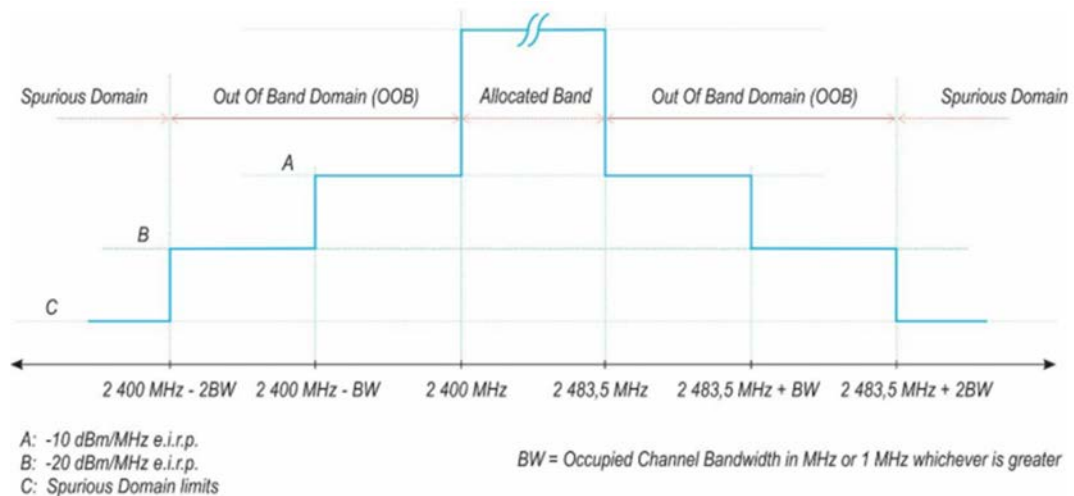

8.6.2 Test Equipment Settings

The measurement shall only be performed at the lowest and the highest channel on which the EUT can operate. In addition, the EUT shall be configured to operate under its worst case situation with respect to output power, which means EUT needs to be operating in continuous transmit mode with maximum output power

level. For each frequency of the channel under test, e.g., 2402 MHz and 2480 MHz for Bluetooth Low Energy device, both of the lower and upper OOB domain should be tested.

The applicable BW shall be set to the greater value between the measurement results from *Section 8.5 Occupied Channel Bandwidth on page 60* and 1 MHz at respective channel under test. The out-of-band emissions within the different horizontal segments of the transmitter mask provided in Figure 8-4 on page 62 shall be measured using the spectrum analyzer settings listed in Table 8-8 and Table 8-9 below.

Table 8-8: Spectrum Analyzer Settings for Lower OOB Emissions

Measuring Parameter	Value
Start Frequency	2400 – 2×BW MHz
Stop Frequency	2400 MHz
RBW (Resolution Bandwidth)	1 MHz
VBW (Video Bandwidth)	3 MHz
Filter Type	Channel filter
Detector Mode	RMS
Trace Mode	Max Hold
Sweep Points	Continuous
Sweep Time	Auto
Sweep Points	5000

Table 8-9: Spectrum Analyzer Settings for Upper OOB Emissions

Measuring Parameter	Value
Start Frequency	2483.5 MHz
Stop Frequency	2483.5 + 2×BW MHz
RBW (Resolution Bandwidth)	1 MHz
VBW (Video Bandwidth)	3 MHz
Filter Type	Channel filter
Detector Mode	RMS
Trace Mode	Max Hold
Sweep Points	Continuous
Sweep Time	Auto
Sweep Points	5000

8.6.3 Explanation of Test Result

Figure 8-5 on page 64 shows a typical example of out-of-band emissions testing at the highest frequency. Despite the operating frequency to be tested is located at 2480 MHz, the unwanted emissions within lower out-of-band range should be

evaluated as well. The same is for the lowest frequency of the channel under test. Note that the 'BW' parameter given in Table 8-8 and Table 8-9 on page 63 should be set as the greater value by comparing measurement result of occupied channel bandwidth individually with fixed 1 MHz.

Figure 8-5: Example Test Plot of OOB Emissions While Operating at Highest Frequency

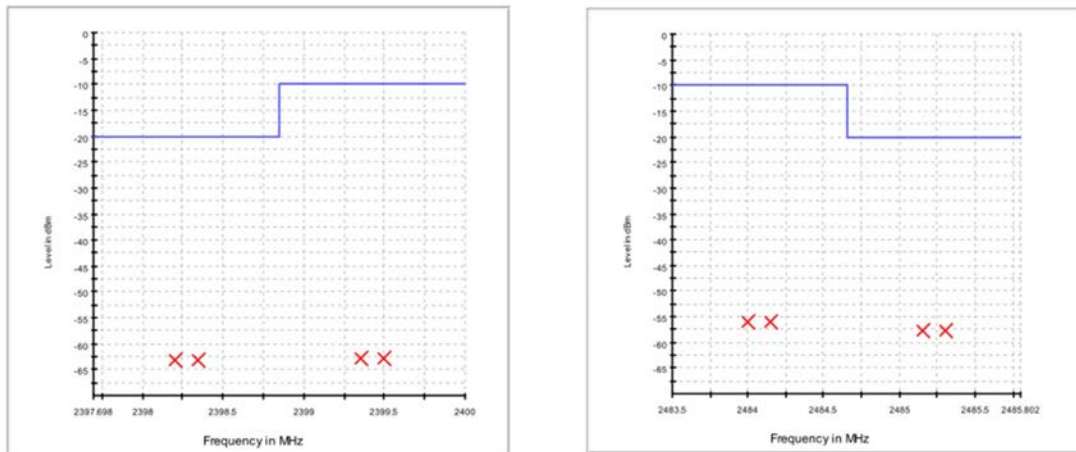

8.7 Transmitter Unwanted Emissions in the Spurious Domain

8.7.1 Definition and Limit

Transmitter unwanted emissions in the spurious domain are emissions outside the allocated band and outside the out-of-band domain as indicated in Figure 8-4 on page 62 when the EUT is in transmit mode.

The transmitter unwanted emissions in the spurious domain shall not exceed the values given in Table 8-10. In case of equipment with antenna connectors, these limits apply to emissions at the antenna port (conducted). For emissions radiated by the cabinet or emissions radiated by integral antenna equipment (without antenna connectors), these limits are e.r.p. for emissions up to 1 GHz and e.i.r.p. for emissions above 1 GHz.

Table 8-10: Transmission Limits for Spurious Emissions

Frequency Range	Maximum Power	Measurement Bandwidth
30 ~ 47 MHz	-36 dBm	100 kHz
47 ~ 74 MHz	-54 dBm	100 kHz
74 ~ 87.5 MHz	-36 dBm	100 kHz
87.5 ~ 118 MHz	-54 dBm	100 kHz
118 ~ 174 MHz	-36 dBm	100 kHz

Table 8-10: Transmission Limits for Spurious Emissions (*Continued*)

Frequency Range	Maximum Power	Measurement Bandwidth
174 ~ 230 MHz	-54 dBm	100 kHz
230 ~ 470 MHz	-36 dBm	100 kHz
470 ~ 862 MHz	-54 dBm	100 kHz
862 MHz ~ 1 GHz	-36 dBm	100 kHz
1 ~ 12.75 GHz	-30 dBm	1 MHz

8.7.2 Test Equipment Settings

These measurements shall only be performed at normal test conditions and at the lowest and the highest channel where the EUT can operate. In addition, the EUT shall be configured to operate under its worst-case situation with respect to output power, which means EUT needs to be operating in continuous transmit mode with maximum output power level.

In case of conducted measurements, the antenna port of EUT shall be connected to spectrum analyzer via RF cable directly. The spectrum analyzer settings are shown in Table 8-11 for emissions over the range 30 MHz to 1 GHz and Table 8-12 for emissions over the range 1 GHz to 12.75 GHz.

Table 8-11: Spectrum Analyzer Settings for 30 MHz to 1 GHz Band

Measuring Parameter	Value
RBW (Resolution Bandwidth)	100 kHz
VBW (Video Bandwidth)	300 kHz
Filter Type	3 dB (Gaussian)
Detector Mode	Peak
Trace Mode	Max Hold
Sweep Points	≥ 19400
Sweep Time	Auto

Table 8-12: Spectrum Analyzer Settings for 1 GHz to 12.75 GHz Band

Measuring Parameter	Value
RBW (Resolution Bandwidth)	1 MHz
VBW (Video Bandwidth)	3 MHz
Filter Type	3 dB (Gaussian)
Detector Mode	Peak
Trace Mode	Max Hold
Sweep Points	≥ 23500
Sweep Time	Auto

NOTE: For spectrum analysers not supporting this high number of sweep points listed above, the frequency band may be segmented.

Allow the trace to stabilize. Any emissions identified during the sweeps above that fall within the 6-dB range below the applicable limit or above, shall be individually measured using the time domain power method and compared to the limits given in Table 8-10 on page 64.

8.8 Receiver Spurious Emissions

8.8.1 Definition and Limit

Receiver spurious emissions are emissions at any frequency when the equipment is in receive mode. The spurious emissions of the receiver shall not exceed the values given in Table 8-13.

In case of EUT with antenna connectors, these limits apply to emissions at the antenna port (conducted). For emissions radiated by the cabinet or emissions radiated by integral antenna equipment (without antenna connectors), these limits are e.r.p. for emissions up to 1 GHz and e.i.r.p. for emissions above 1 GHz.

Table 8-13: Spurious Emission Limit for Receiver

Frequency Range	Maximum Power	Measurement Bandwidth
30 MHz ~ 1 GHz	-57 dBm	100 kHz
1 ~ 12.75 GHz	-47 dBm	1 MHz

8.8.2 Test Equipment Settings

Receiver spurious emissions testing shall be performed when the EUT is in a receive-only mode, the measurement shall be performed at the lowest and the highest channel on which the equipment can operate.

Please refer to Table 8-11 and Table 8-12 on page 65 for spectrum analyzer settings. Wait for the trace to stabilize. Any emissions identified during the sweeps above and that fall within the 6-dB range below the applicable limit or above, shall be individually measured using the time domain power method and compared to the limits given in Table 8-13.

8.9 Receiver Blocking

8.9.1 Definition and Limit

Receiver blocking is a measure of the ability of the equipment to receive a wanted signal on its operating channel without exceeding a given degradation in the presence of an unwanted signal (blocking signal) on frequencies other than those of the operating band 2400~2483.5 MHz. The minimum performance criterion shall be a PER less than or equal to 10%.

While maintaining the minimum performance criteria as defined above, the blocking levels at specified frequency offsets shall be equal to or greater than the limits defined for EUT with Bluetooth Low Energy function provided in following Table 8-14.

Table 8-14: Receiver Blocking Parameters for Bluetooth Low Energy Equipments

Wanted Signal Power (dBm)	Blocking Signal Frequency (MHz)	Blocking Signal Power (dBm)	Type of Blocking Signal
$P_{\min} + 6$ dB	2380	-57	Continuous Carrier Wave
	2503.5		
$P_{\min} + 6$ dB	2300	-47	Continuous Carrier Wave
	2583.5		

NOTE:

- P_{\min} is the minimum level of the wanted signal (in dBm) required to meet the minimum performance criteria ($PER \leq 10\%$) as defined above in the absence of any blocking signal.
- The power levels specified are levels in front of the EUT's antenna. In case of conducted measurements, the levels have to be corrected by the actual antenna gain.

8.9.2 Test Set-up

Receiver blocking measurements shall only be performed at normal test conditions. For EUT with Bluetooth Low Energy function, having more than one operating channel, the EUT shall be tested operating at both the lowest and highest operating channels. Figure 8-6 on page 68 shows the test set-up which can be used for performing conducted receiver blocking test.

Figure 8-6: Test Setup for Receiver Blocking Measurements

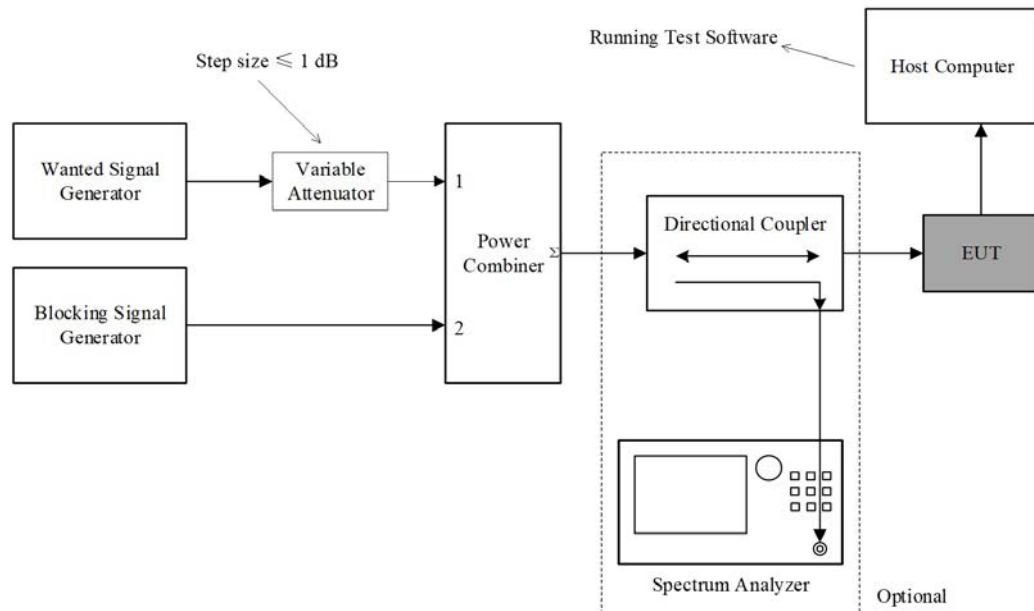

8.9.3 Test Procedure

The procedure below shall be used to verify the receiver blocking requirement:

1. Set EUT to the lowest operating channel by test software installed in computer.
2. The blocking signal generator is set to the first frequency as defined in Table 8-14 on page 67.
3. With the blocking signal generator switched off, a communication link is established between EUT and wanted signal generator using the test setup shown in Figure 8-6. The attenuation of the variable attenuator shall be increased in 1 dB steps to a value at $PER \leq 10\%$ as specified in *Section 8.9.1 Definition and Limit on page 67* is still met. The resulting level for the wanted signal at the input of EUT is P_{min} . Then this signal level (P_{min}) is increased by 6 dBm.
4. The blocking signal at the EUT antenna port is set to the level provided in Table 8-14 on page 67. It shall be verified and recorded in the test report that the performance criteria ($PER \leq 10\%$) as specified in *Section 8.9.1 Definition and Limit on page 67* is met.
5. Repeat step 4) for each remaining combination of frequency and level for the blocking signal as provided in Table 8-14 on page 67.



© 2022 Ambiq Micro, Inc. All rights reserved.

6500 River Place Boulevard, Building 7, Suite 200, Austin, TX 78730

www.ambiq.com

sales@ambiq.com

+1 (512) 879-2850

A-SOCAPG-UGGA01EN v2.1

July 2022