

Apollo3 Blue Plus EVB Connection Diagram

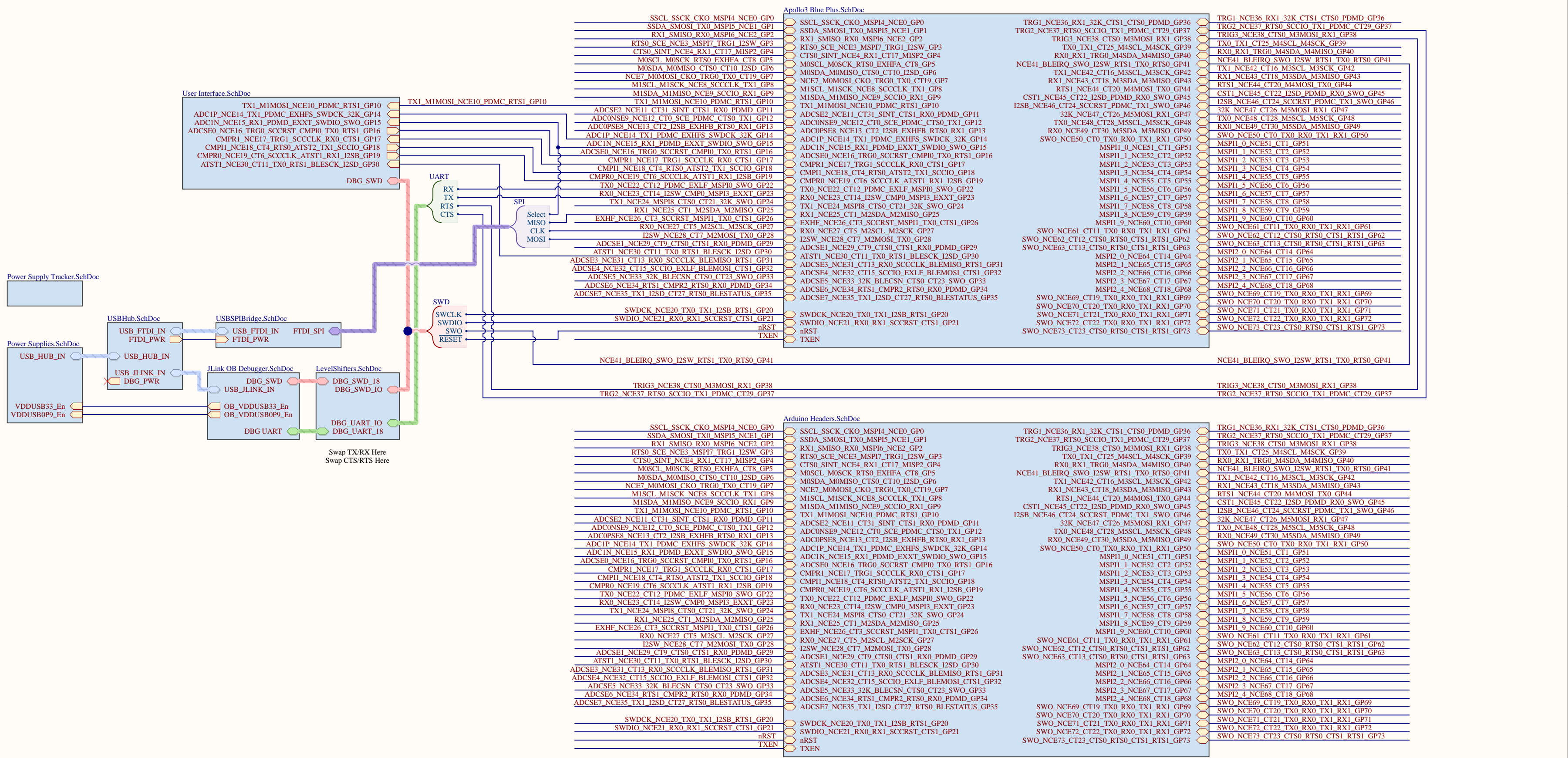

Revision History

Revision 2:
Incremental update to support the new Apollo4 Onboard JLINK debugger.

		Title Apollo3 Blue Plus EVB	
Site A	Number AMA3B1KK-EVB	Revision 2	Sheet 1 of 10
Date 10/17/2022	Drawn By Chad Crosby	Date 10/17/2022	Aprvd By Daniel Lanzone
6500 River Place Boulevard Building 7, Suite 200 Austin, TX 78730 +1 (512) 879-2850			
<small>This document contains information proprietary to Ambiq and shall not be used, reproduced, or disclosed to others, in part or in whole, without express written permission from Ambiq.</small>			

Apollo3 Blue Plus

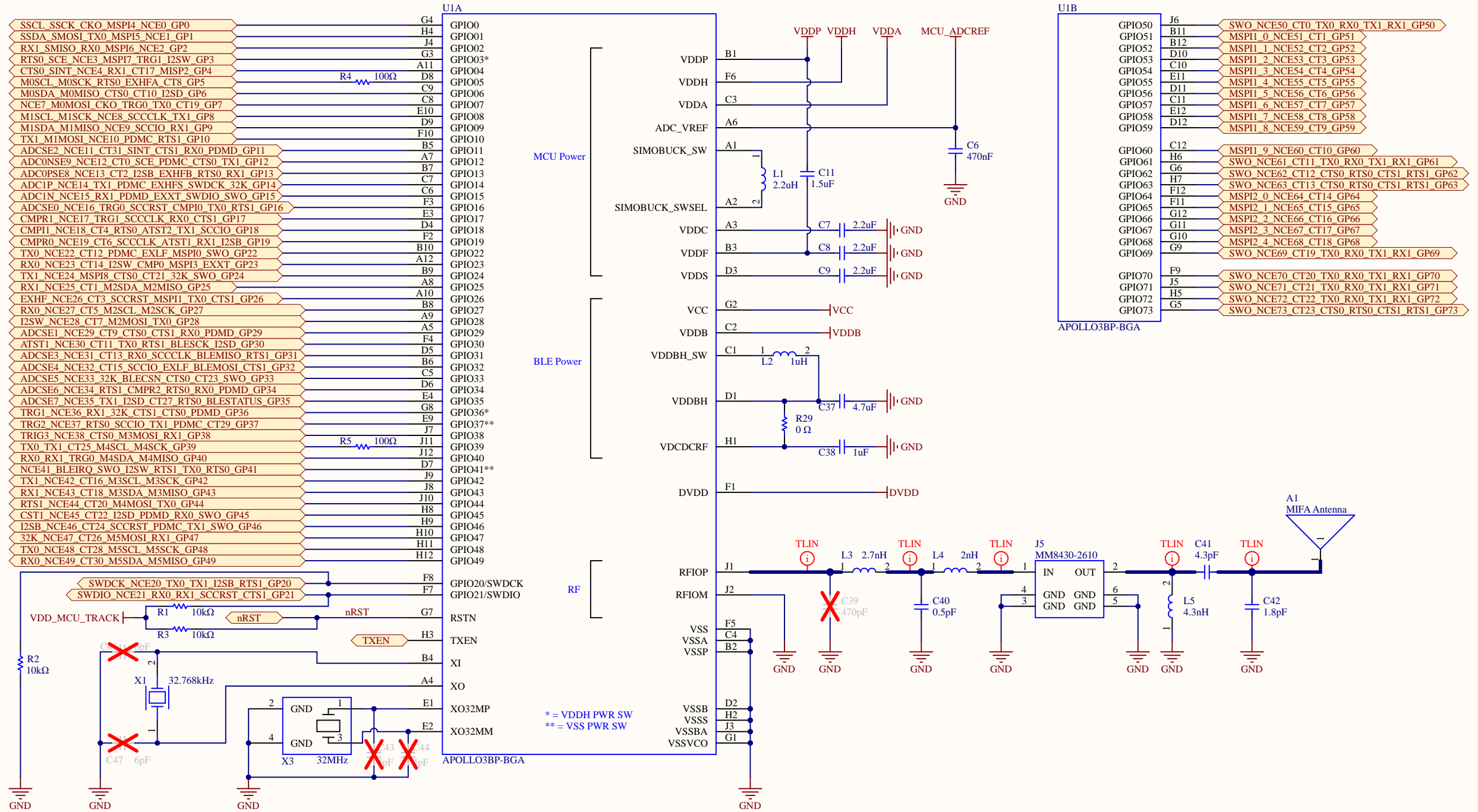

Decoupling Capacitors

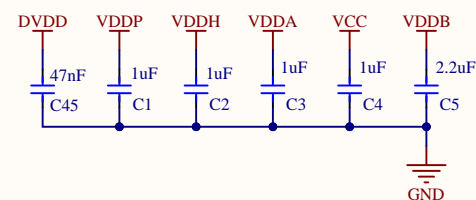

Power Supply Connections



6500 River Place Boulevard
Building 7, Suite 200
Austin, TX 78730
+1 (512) 879-2850

Title: Apollo3 Blue Plus EVB

Size: A Number: AMA3B1KK-EVB Revision: 2 Sheet 2 of 10

Date: 10/17/2022 Drawn By: Chad Crosby 10/17/2022
Aprvd By: Daniel Lanzone 10/17/2022

This document contains information proprietary to Ambiq and shall not be used, reproduced, or disclosed to others, in part or in whole, without express written permission from Ambiq.

Arduino Style & Breakout Headers

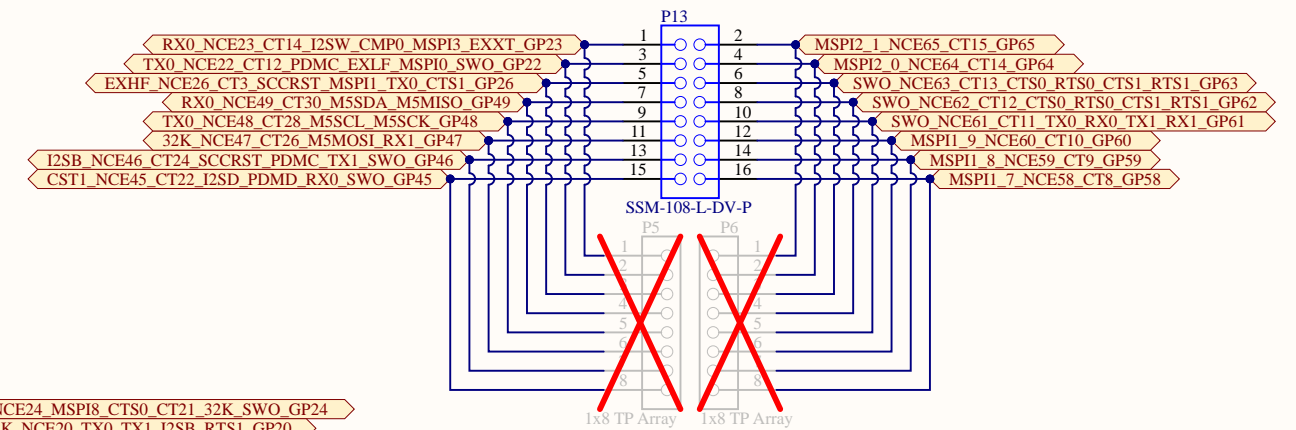
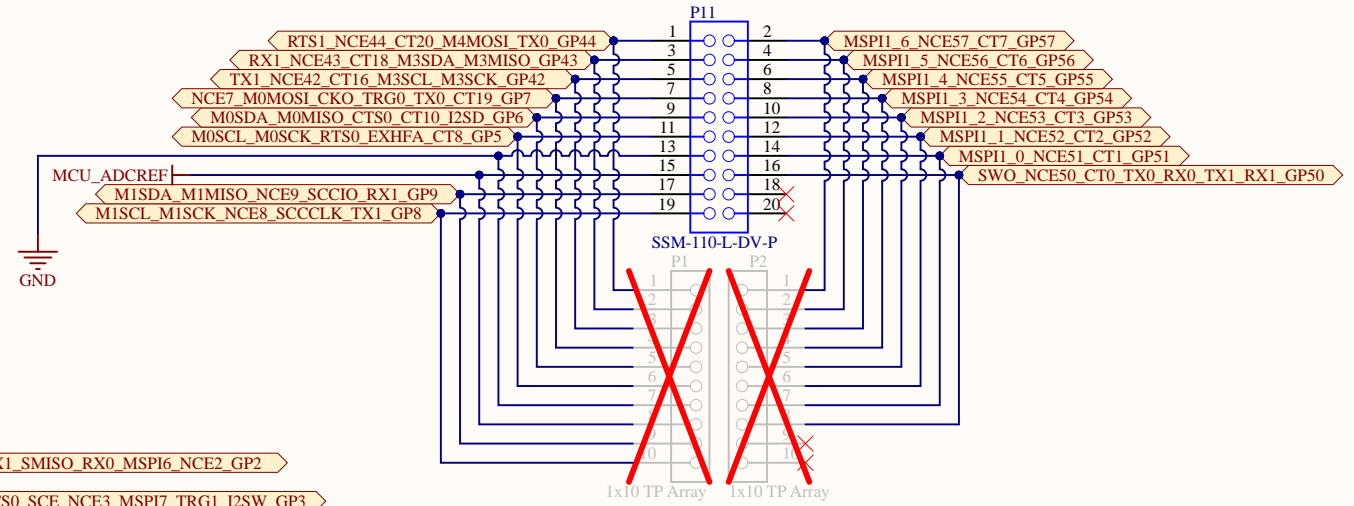
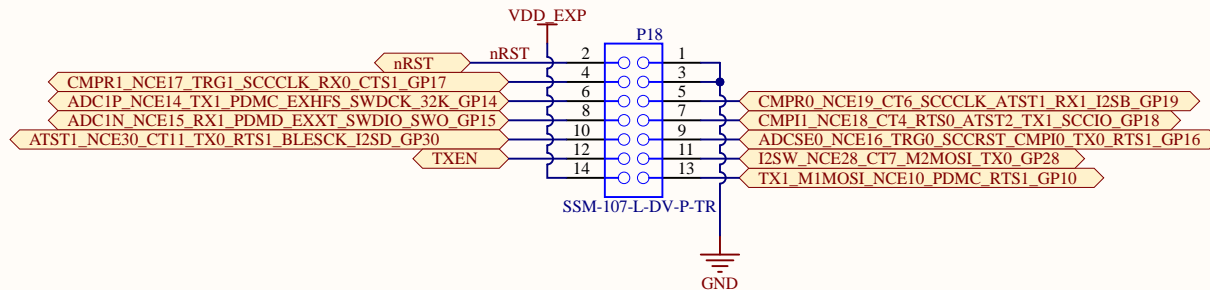
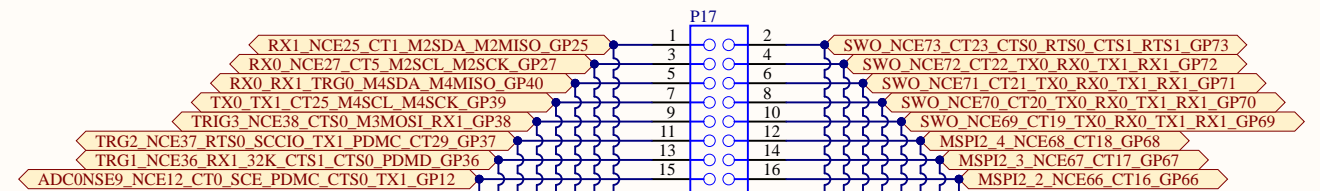
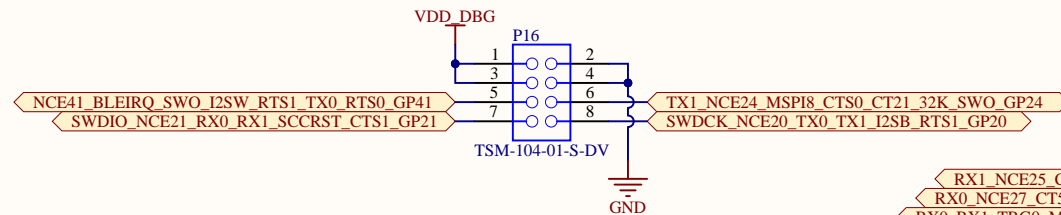
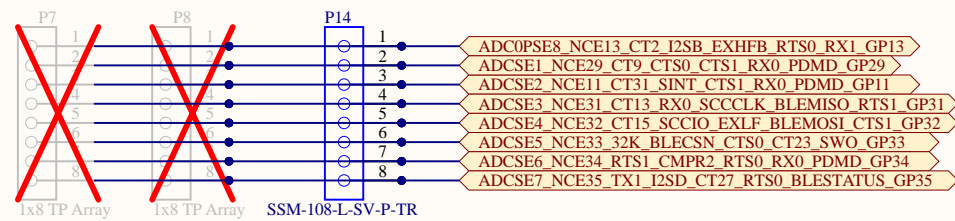
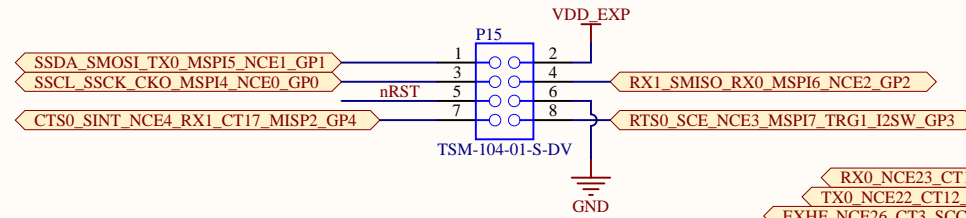
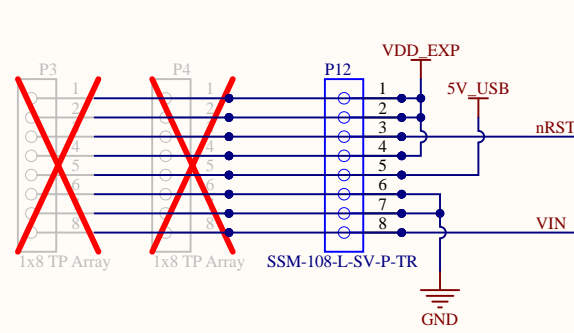



6500 River Place Boulevard
Building 7, Suite 200
Austin, TX 78730
+1 (512) 879-2850

Title: Apollo3 Blue Plus EVB

Size	Number	Revision
A	AMA3B1KK-EVB	2

Sheet 3 of 10

Date	Drawn By	Date
10/17/2022	Chad Crosby	10/17/2022
	Aprvd By	
	Daniel Lanzone	10/17/2022

This document contains information proprietary to Ambiq and shall not be used, reproduced, or disclosed to others, in part or in whole, without express written permission from Ambiq.

USB-C Connector and Protection

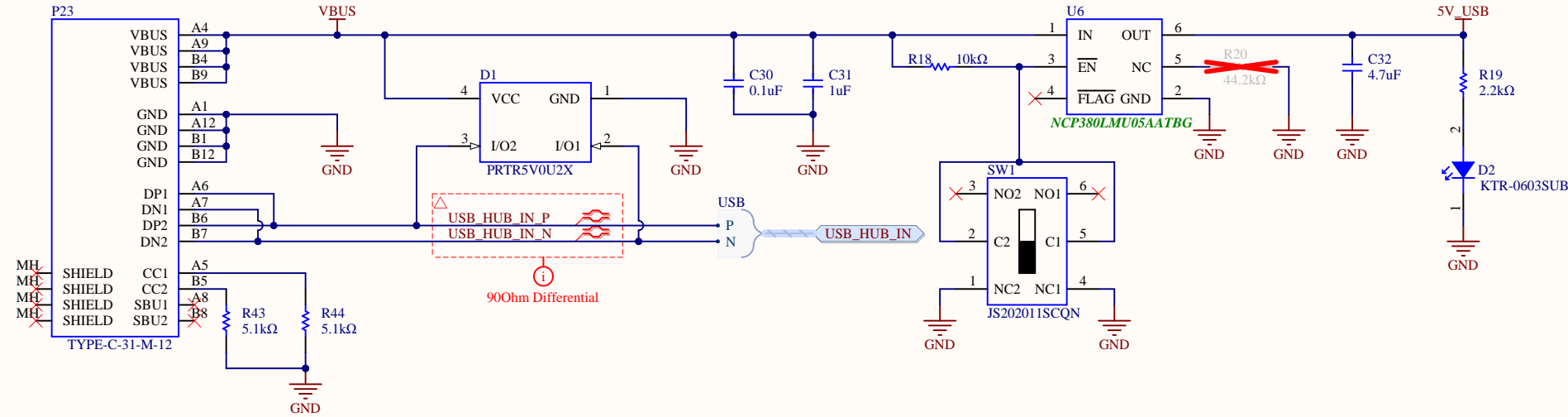

VDDUSB3V3 Loadswitch

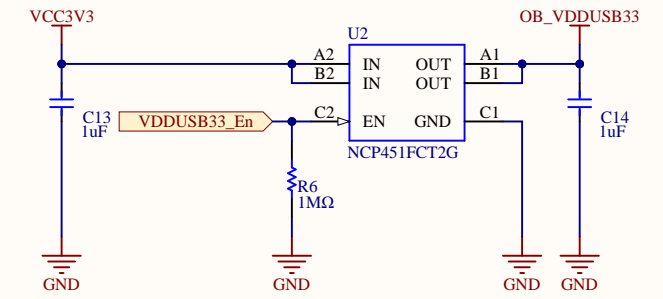

Oboard Debugger and Interface Power Supplies

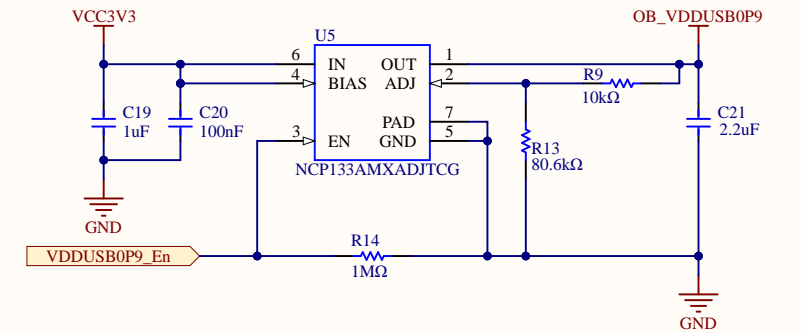
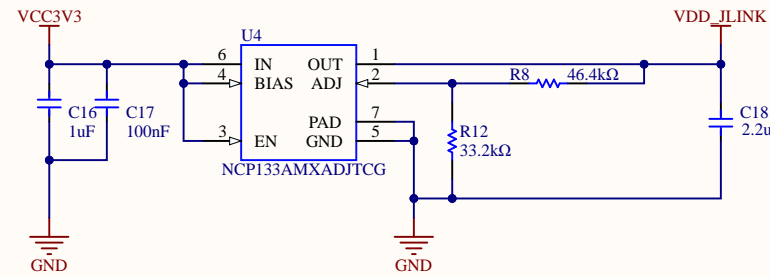
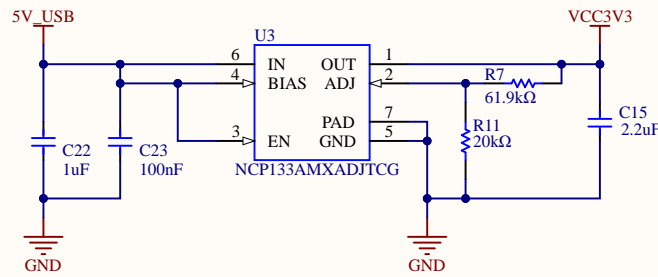

MCU Regulator 3.3V / 1.8V

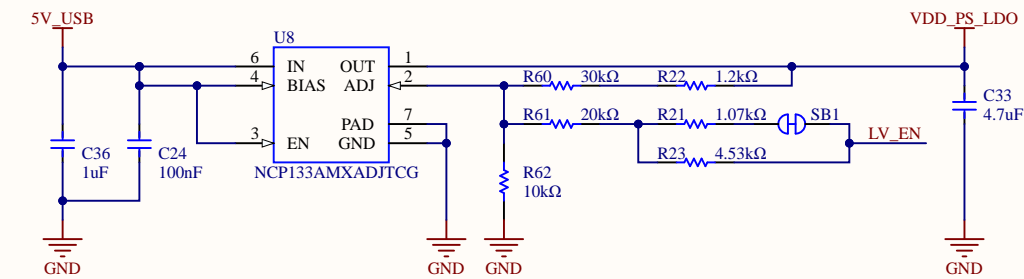

Power Supply Measurement Header

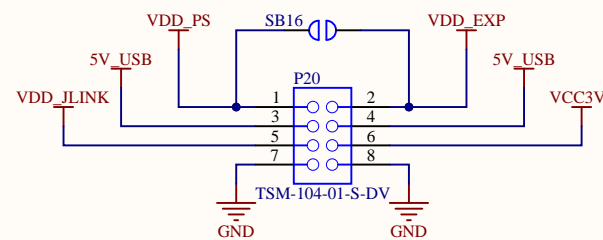

Power Supply Selection Jumper

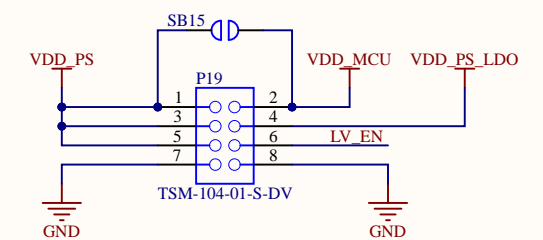

		Title	
		Apollo3 Blue Plus EVB	
Size	Number	Revision	
B	AMA3B1KK-EVB	2	Sheet 4 of 10
Date	Drawn By		
10/15/2022	Chad Crosby	10/15/2022	
	Aprvd By		
	Daniel Lanzone	10/17/2022	
<small>This document contains information proprietary to Ambiq and shall not be used, reproduced, or disclosed to others, in part or in whole, without express written permission from Ambiq.</small>			

Power Supply Tracker

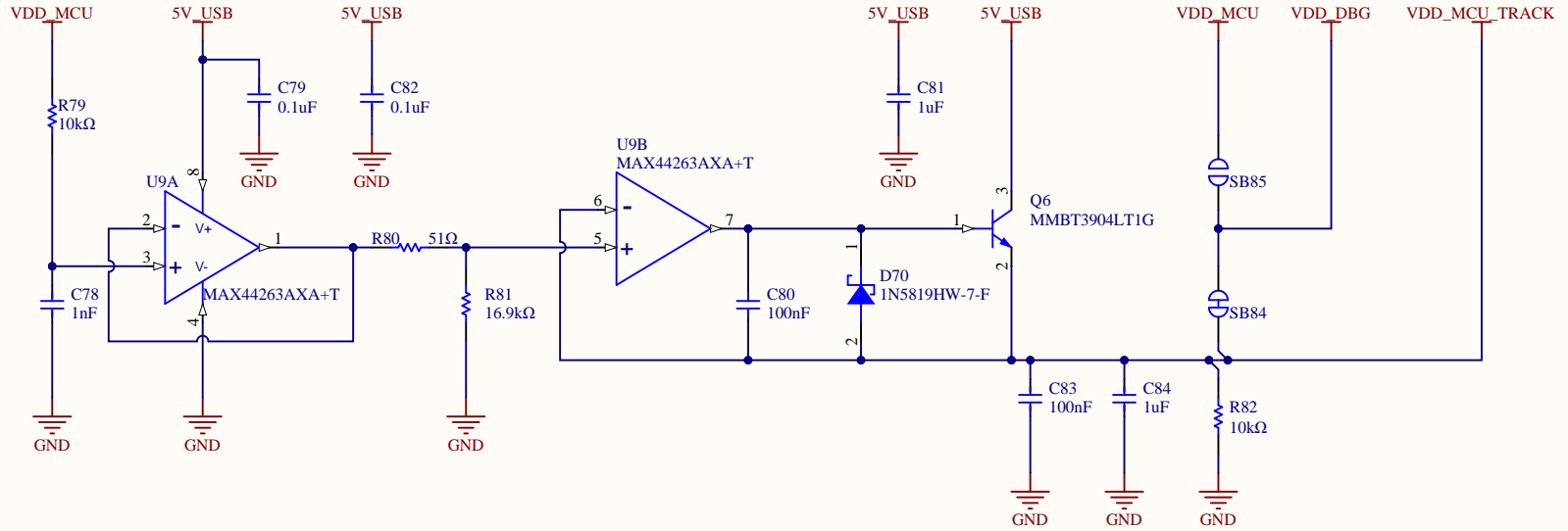

6500 River Place Boulevard
 Building 7, Suite 200
 Austin, TX 78730
 +1 (512) 879-2850

Title		Apollo3 Blue Plus EVB	
Size	Number	Revision	
A	AMA3B1KK-EVB	2	Sheet 5 of 10
Date	Drawn By		
10/17/2022	Chad Crosby	10/17/2022	
	Aprvd By		
	Daniel Lanzone	10/17/2022	

This document contains information proprietary to Ambiq and shall not be used, reproduced, or disclosed to others, in part or in whole, without express written permission from Ambiq.

Apollo4 JLINK OB Debugger

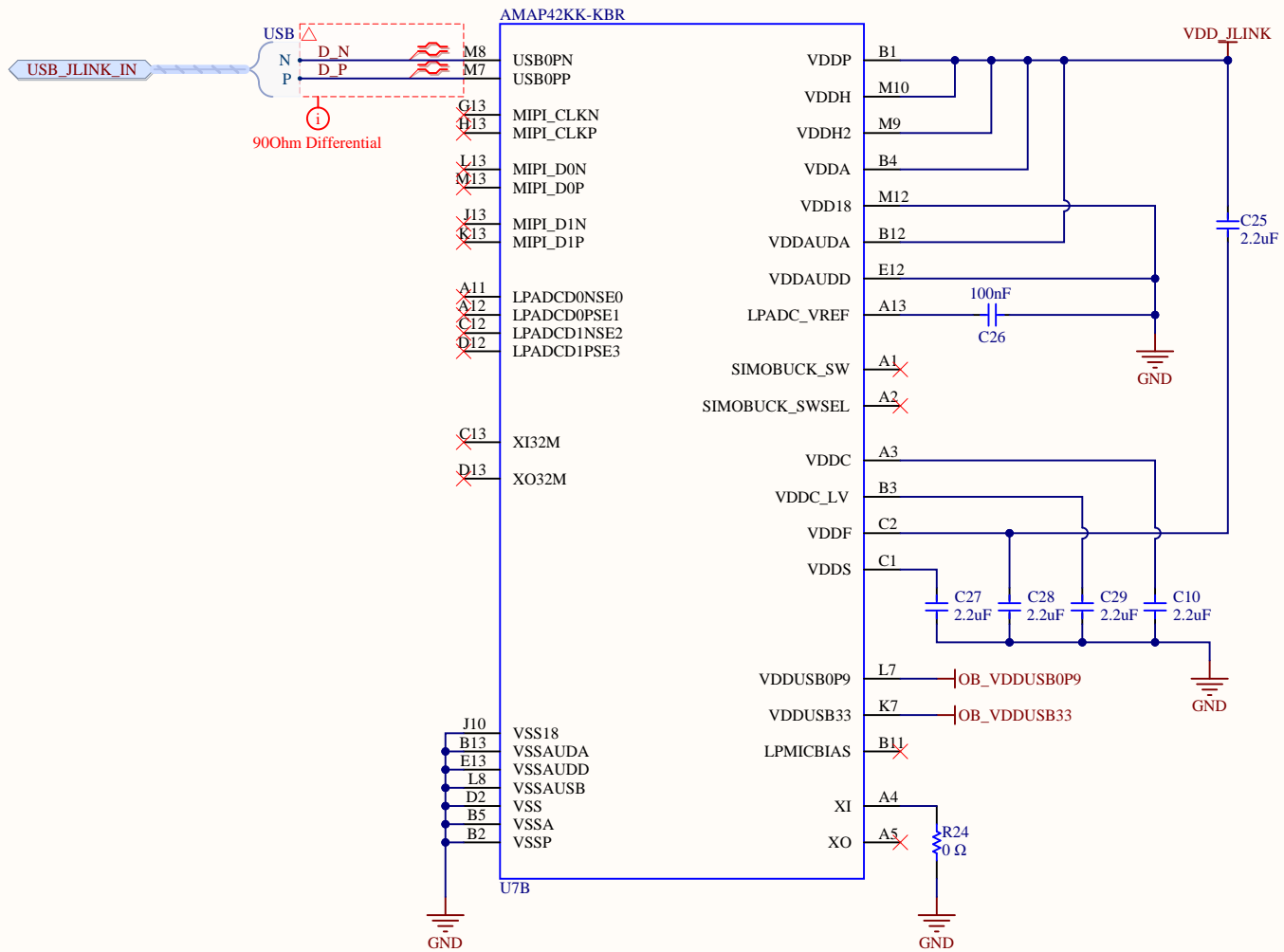
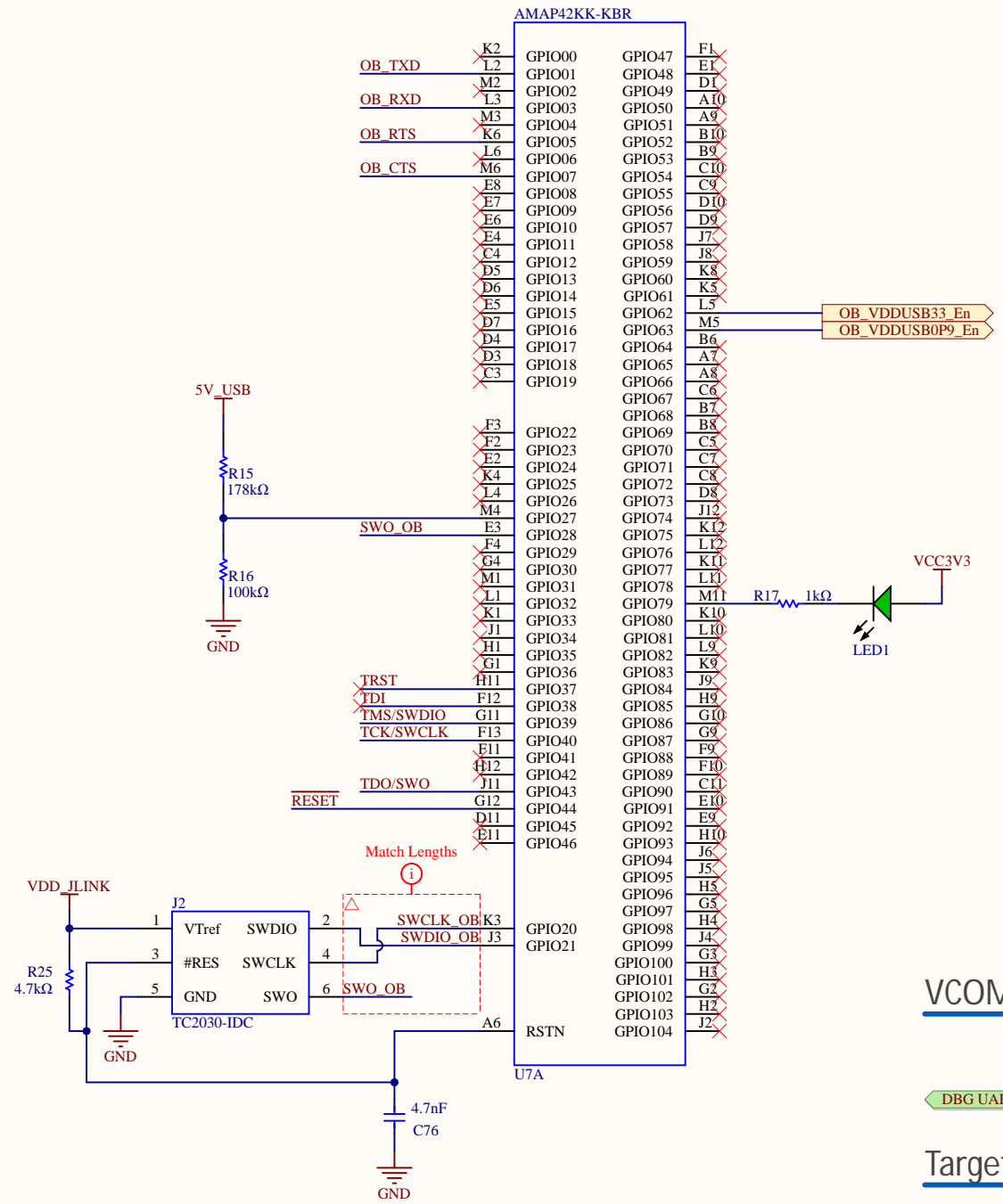

VCOM Interface

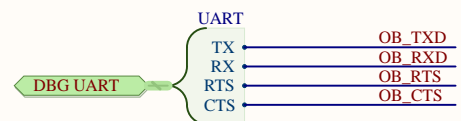

Target Debug Interface



Decoupling Capacitors

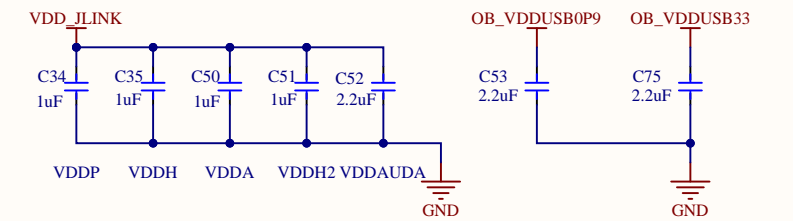

Title: Apollo3 Blue Plus EVB

Size	Number	Revision	Sheet
B	AMA3B1KK-EVB	2	6 of 10

Date: 10/14/2022 Drawn By: Chad Crosby 10/14/2022

Date: 10/14/2022 Aprvd By: Daniel Lanzone 10/17/2022

6500 River Place Boulevard
Building 7, Suite 200
Austin, TX 78730
+1 (512) 879-2850

This document contains information proprietary to Ambiq and shall not be used, reproduced, or disclosed to others, in part or in whole, without express written permission from Ambiq.

LEDs

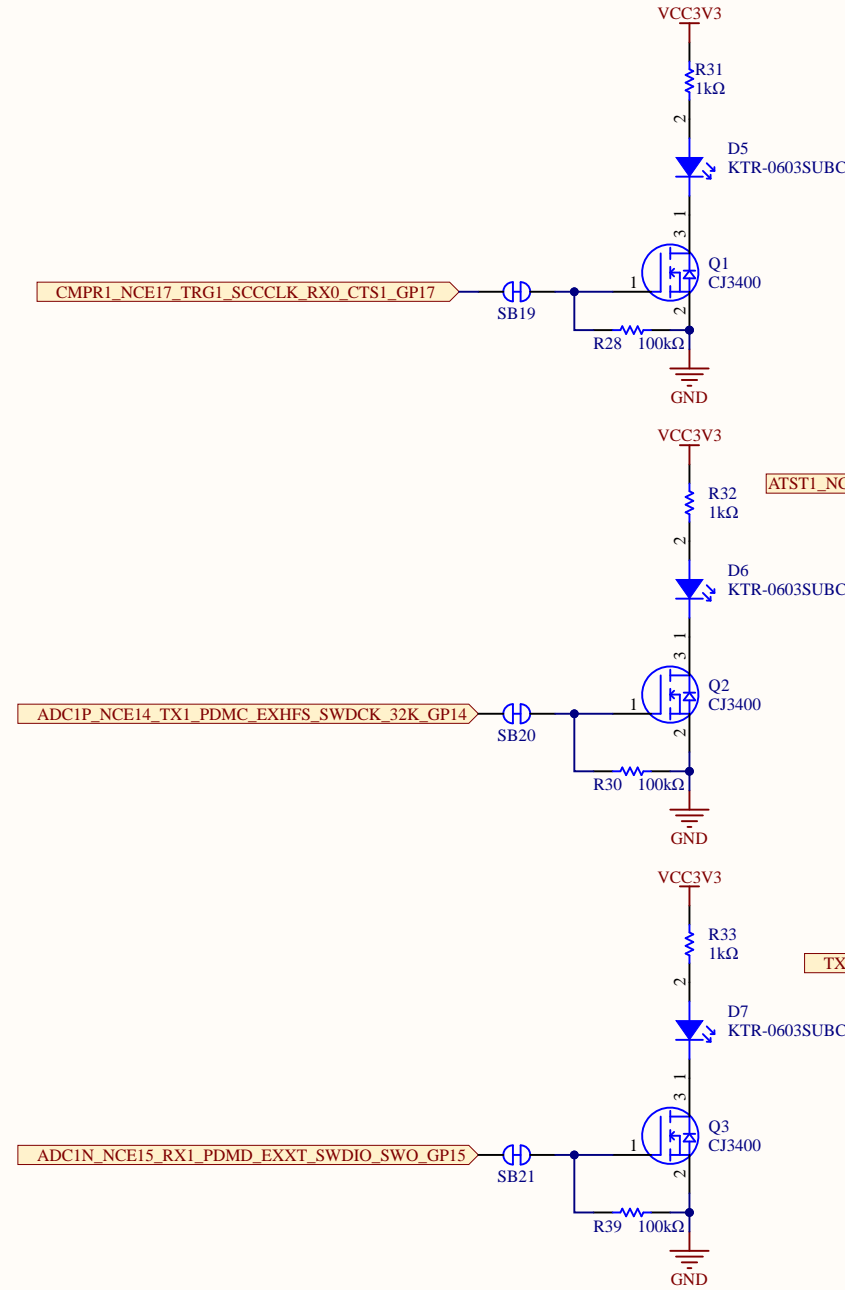

Push Buttons

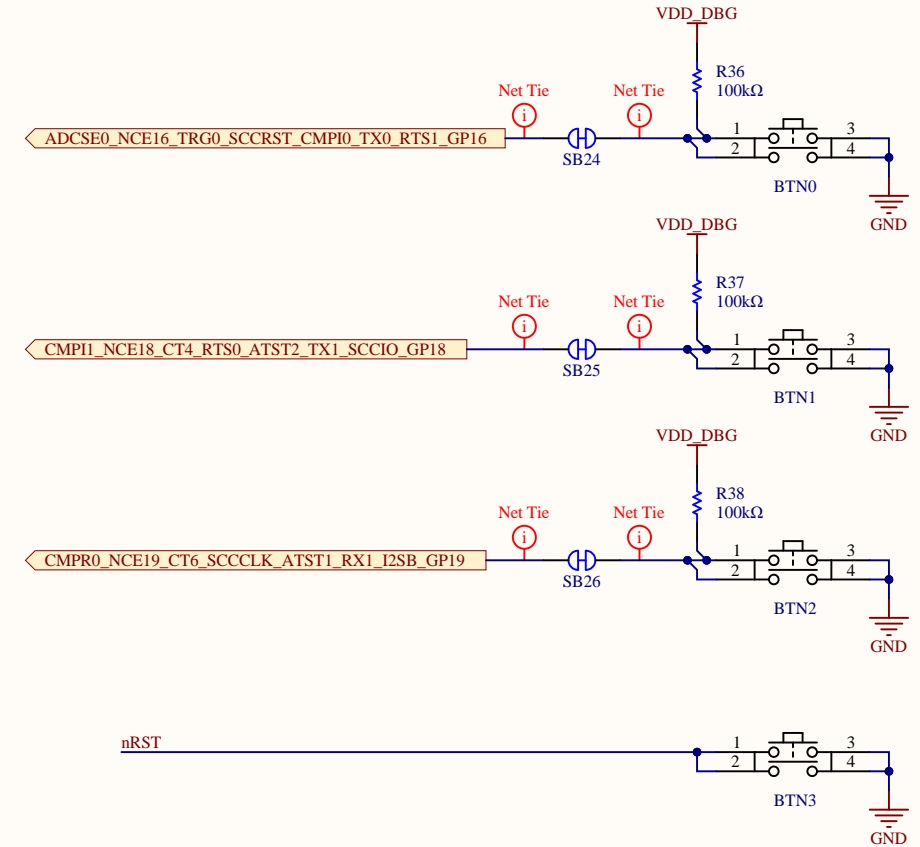

Debug In Header

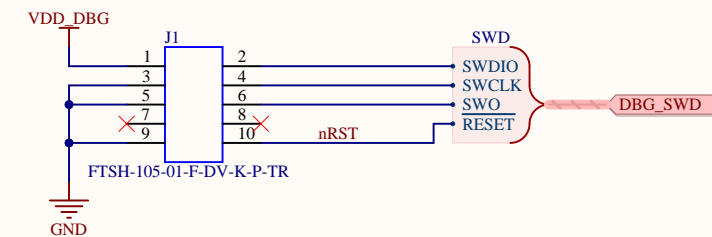

GND Hooks

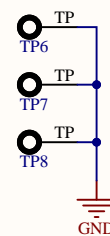

Fiducials

Fiducial P21
 Fiducial P22

		Title Apollo3 Blue Plus EVB		
		Size A	Number AMA3B1KK-EVB	Revision 2
6500 River Place Boulevard Building 7, Suite 200 Austin, TX 78730 +1 (512) 879-2850		Date 10/12/2022	Drawn By Chad Crosby Aprvd By Daniel Lanzzone	Date 10/12/2022 Date 10/17/2022

This document contains information proprietary to Ambiq and shall not be used, reproduced, or disclosed to others, in part or in whole, without express written permission from Ambiq.

J-Link SWD Connections and Level Translation

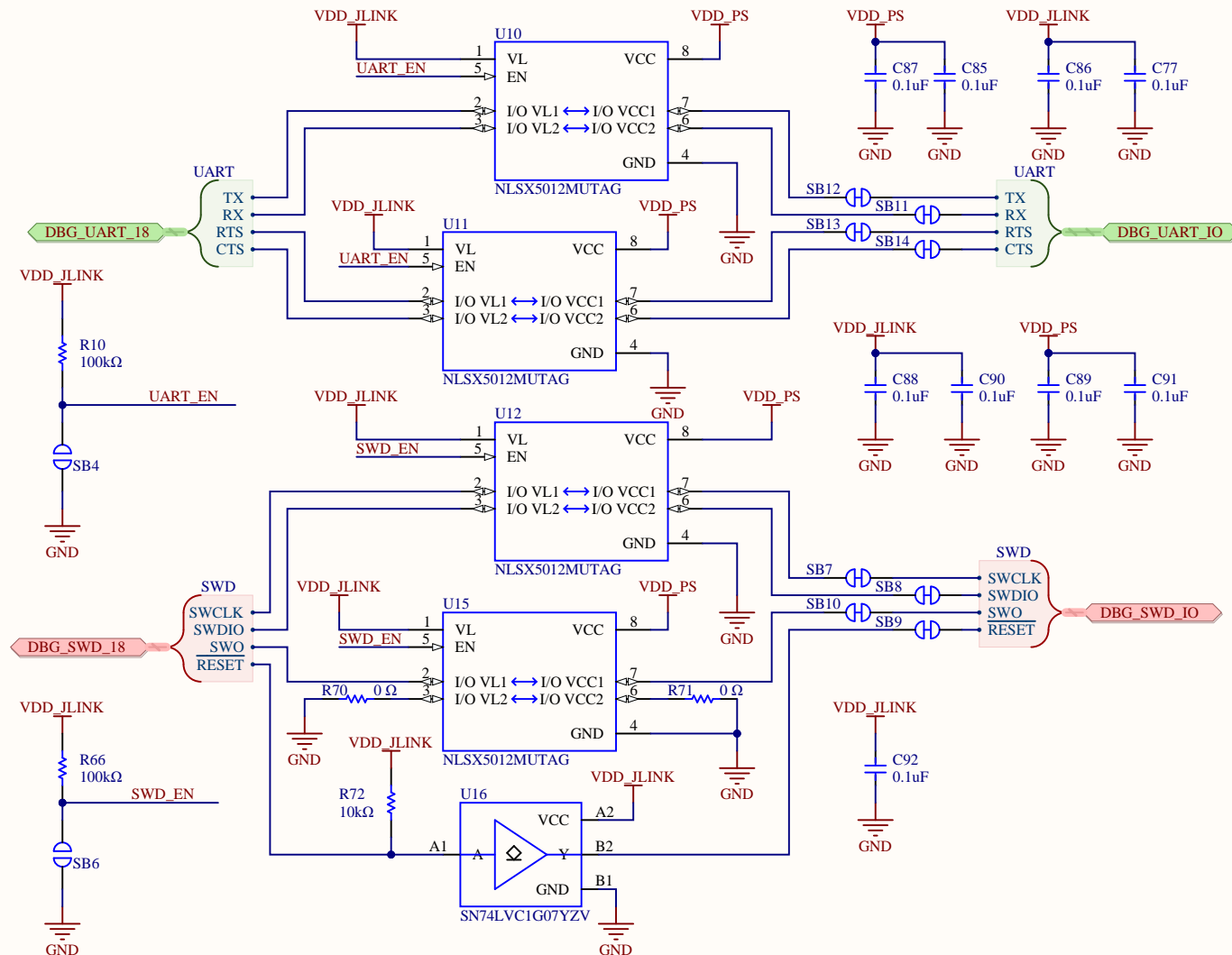

		Title	
		Apollo3 Blue Plus EVB	
Size	Number	Revision	
B	AMA3B1KK-EVB	2	Sheet 8 of 10
Date	Drawn By		
10/7/2022	Chad Crosby	10/7/2022	
	Aprvd By		
	Daniel Lanzone	10/17/2022	
<small>This document contains information proprietary to Ambiq and shall not be used, reproduced, or disclosed to others, in part or in whole, without express written permission from Ambiq.</small>			

USB Hub

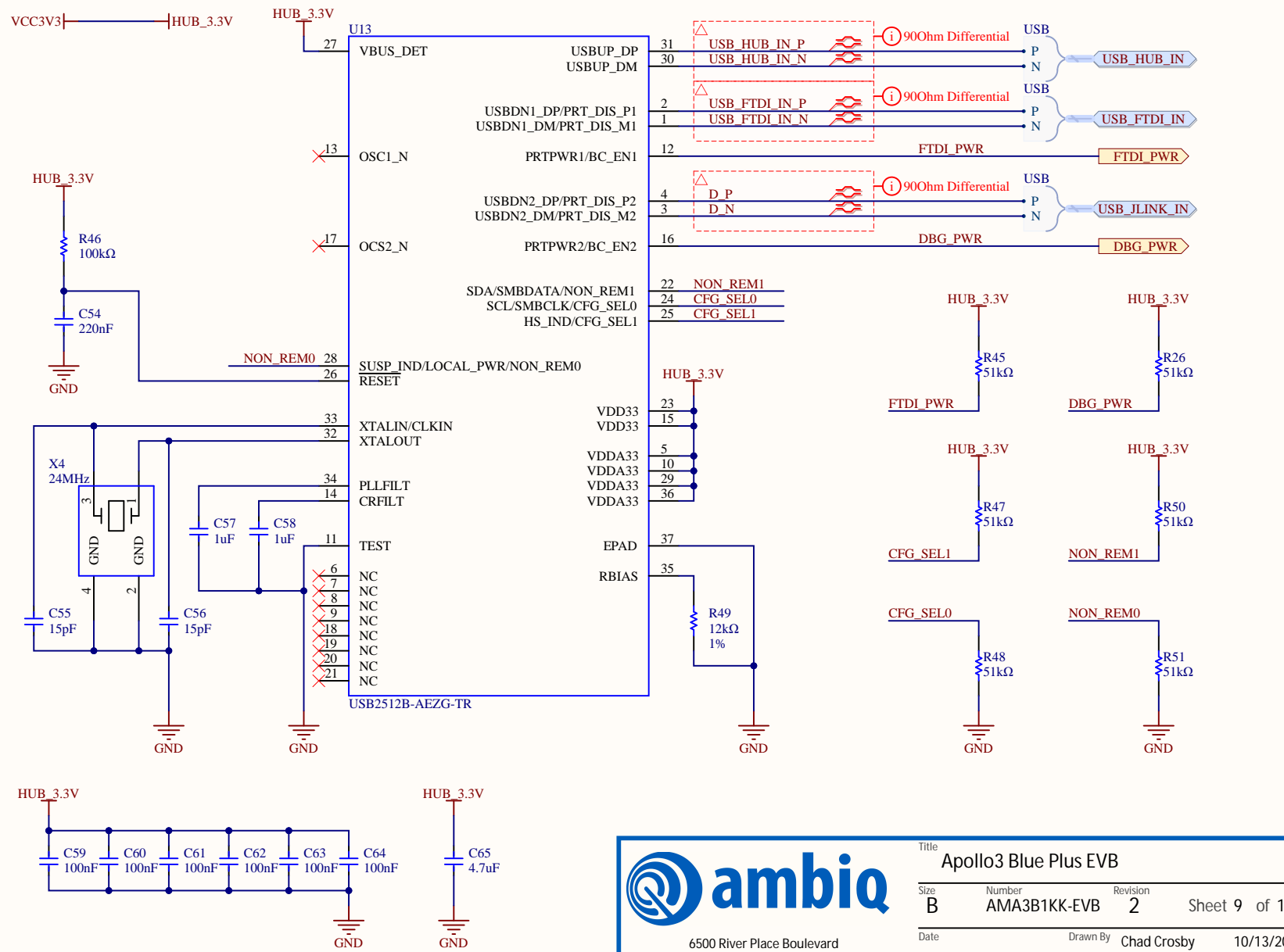

			
6500 River Place Boulevard Building 7, Suite 200 Austin, TX 78730 +1 (512) 879-2850			
Title Apollo3 Blue Plus EVB			
Size B	Number AMA3B1KK-EVB	Revision 2	Sheet 9 of 10
Date 10/13/2022	Drawn By Chad Crosby	10/13/2022	
	Aprvd By Daniel Lanzone	10/17/2022	
This document contains information proprietary to Ambiq and shall not be used, reproduced, or disclosed to others, in part or in whole, without express written permission from Ambiq.			

USB Hub

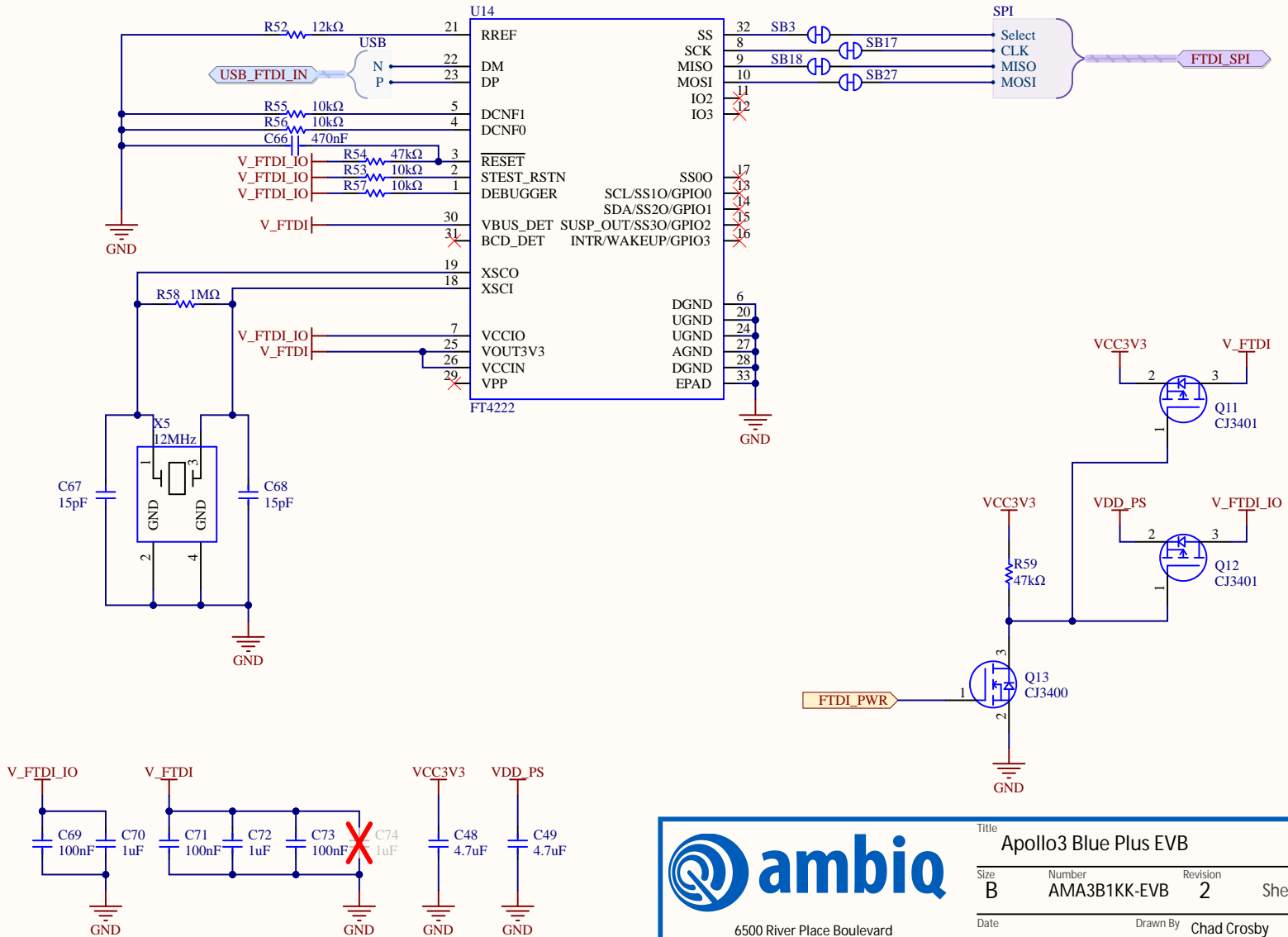

Title			
Apollo3 Blue Plus EVB			
Size	Number	Revision	
B	AMA3B1KK-EVB	2	Sheet 10 of 10
Date	Drawn By		
10/13/2022	Chad Crosby	10/13/2022	
	Aprvd By		
	Daniel Lanzone	10/17/2022	

6500 River Place Boulevard
 Building 7, Suite 200
 Austin, TX 78730
 +1 (512) 879-2850

This document contains information proprietary to Ambiq and shall not be used, reproduced, or disclosed to others, in part or in whole, without express written permission from Ambiq.