



USER'S GUIDE

Hardware Design Guidelines

For Apollo510, Apollo510B, Apollo510 Lite, Apollo330 Plus, Apollo4 Family
and Apollo3 Family SoCs

A-SOCAPG-UGGA02EN v4.0



Legal Information and Disclaimers

AMBIQ MICRO BELIEVES THE INFORMATION IN THIS DOCUMENT IS ACCURATE AT THE TIME OF PUBLICATION. HOWEVER, THE INFORMATION MAY CONTAIN TECHNICAL INACCURACIES OR TYPOGRAPHICAL ERRORS. AMBIQ MICRO RESERVES THE RIGHT TO MAKE CORRECTIONS, MODIFICATIONS, ENHANCEMENTS, IMPROVEMENTS, OR OTHER CHANGES TO ITS PRODUCTS (AND DOCUMENTATION) AT ANY TIME WITHOUT NOTICE.

INFORMATION IN THIS DOCUMENT IS PROVIDED SOLELY TO ENABLE THE USE OF AMBIQ MICRO PRODUCTS AND IS PROVIDED "AS IS." NO LICENSE IS GRANTED TO DESIGN OR FABRICATE ANY INTEGRATED CIRCUITS BASED ON THE INFORMATION IN THIS DOCUMENT. THIS DOCUMENT MAY NOT BE USED IN CONNECTION WITH ANY LEGAL ANALYSIS CONCERNING THE AMBIQ MICRO PRODUCTS DESCRIBED HEREIN. AMBIQ MICRO DISCLAIMS ALL WARRANTIES, EXPRESS OR IMPLIED, INCLUDING WITHOUT LIMITATION WARRANTIES OF MERCHANTABILITY, FITNESS FOR A PARTICULAR PURPOSE, TITLE, AND NON-INFRINGEMENT.

AMBIQ MICRO PRODUCTS ARE SOLD SUBJECT TO AMBIQ MICRO'S TERMS AND CONDITIONS OF SALE; SOFTWARE IS PROVIDED PURSUANT TO APPLICABLE LICENSE TERMS. NO LICENSE, EXPRESS OR IMPLIED, BY ESTOPPEL OR OTHERWISE, IS GRANTED UNDER ANY INTELLECTUAL PROPERTY RIGHT OF AMBIQ MICRO OR ANY THIRD PARTY BY THIS DOCUMENT.

CUSTOMERS ARE SOLELY RESPONSIBLE FOR THE DESIGN, VALIDATION, TESTING, AND SECURITY OF THEIR PRODUCTS AND APPLICATIONS, INCLUDING THE SPECIFIC MANNER IN WHICH AMBIQ MICROS PRODUCTS ARE INCORPORATED. "TYPICAL" PARAMETERS ARE FOR REFERENCE ONLY AND IT IS THE CUSTOMER'S RESPONSIBILITY TO VALIDATE "TYPICAL" SPECIFICATIONS FOR THEIR APPLICATION.

AMBIQ MICRO PRODUCTS ARE NOT DESIGNED OR AUTHORIZED FOR USE IN APPLICATIONS WHERE PRODUCT FAILURE COULD RESULT IN PERSONAL INJURY, DEATH, OR SEVERE PROPERTY OR ENVIRONMENTAL DAMAGE ("HIGH-RISK APPLICATIONS") WITHOUT EXPRESS WRITTEN APPROVAL. IF PRODUCTS ARE USED IN HIGH-RISK APPLICATIONS WITHOUT SUCH APPROVAL, THE CUSTOMER SHALL INDEMNIFY AND HOLD HARMLESS AMBIQ MICRO AND ITS AFFILIATES FROM ALL RESULTING CLAIMS, DAMAGES, COSTS, AND EXPENSES, INCLUDING REASONABLE ATTORNEYS' FEES. IN NO EVENT SHALL AMBIQ MICRO BE LIABLE FOR ANY INDIRECT, INCIDENTAL, SPECIAL, CONSEQUENTIAL, OR PUNITIVE DAMAGES, INCLUDING LOST PROFITS OR DATA, ARISING FROM THE USE OF THIS DOCUMENT OR ANY PRODUCT.

"AMBIQ", "APOLLO", "SPOT", AND COMBINATIONS THEREOF ARE TRADEMARKS OF AMBIQ MICRO, INC. OTHER PRODUCT NAMES USED IN THIS PUBLICATION ARE FOR IDENTIFICATION PURPOSES ONLY AND MAY BE TRADEMARKS OF THEIR RESPECTIVE COMPANIES.

Revision History

Table 1-1: Revision History

Revision	Date	Description
1.0	November 4, 2022	Initial release
1.1	November 29, 2023	Updated Section 14.2 guidelines for ETM, IOM SPI and MSPI.
2.0	January 2025	Added content for Apollo510 SoC.
2.1	February 2025	Section 3.3.1 Apollo510 Guidelines: Recommended Taiyo Yuden inductor P/N updated.
3.0	October 2025	Added content for Apollo510B SoC
4.0	May 2026	Updated section 9.3.5 (VDDUSB33 Current Leakage) to also apply to Apollo510 SoCs) Added content for Apollo510 Lite SoC and Apollo330 Plus SoC sections

Reference Documents

These reference documents can be accessed on the [Ambiq Website](#) and/or [Content Portal](#), or by contacting your Ambiq sales representative.

Table 1-2: Reference Documents

Document ID	Description
DS-A510L-*	Apollo510 Lite Datasheet
DS-A330P-*	Apollo330 Plus Datasheet
SE-A510L-*	Apollo510 Lite Silicon Errata List
SE-A330P-*	Apollo330 Plus Silicon Errata List
DS-A510B-*	Apollo510B Datasheet
DS-A510-*	Apollo510 Datasheet
SE-A510-*	Apollo510/510B Silicon Errata List
RM-A5-*	Apollo5 Family SoCs Reference Manual
DS-A4BP-*	Apollo4 Blue Plus SoC Datasheet
DS-A4P-*	Apollo4 Plus SoC Datasheet
DS-A4B-*	Apollo4 Blue SoC Datasheet
DS-A4-*	Apollo4 SoC Datasheet
PG-A4-*	Apollo4 Family Programmer's Guide
SE-A4P-*	Apollo4 Plus Silicon Errata List
SE-A4-*	Apollo4 and Apollo4 Blue Silicon Errata List
A-SOCAP4-ANGA01EN	Design Guidelines on Magnetic Immunity Application Note
SE-A3P-*	Apollo3 Blue Plus Silicon Errata List
SE-A3-*	Apollo3 Blue Silicon Errata List
See Content Portal	Apollo4 Family SoC Pin Mapping Spreadsheets
See Content Portal	Apollo3 Blue and Apollo3 Blue Plus SoC Pin Mapping Spreadsheets

* Please use the latest version of document

Table of Contents

1. Introduction	10
2. Voltage Supply Capacitor Guidelines	11
2.1 Overview	11
2.2 Scope	11
2.3 Guidelines	11
2.3.1 Apollo510 SoC.....	11
2.3.2 Apollo510B SoC.....	12
2.3.3 Apollo510 Lite and Apollo330 Plus SoCs	13
2.3.4 Apollo4 SoC Family	15
2.3.5 Apollo3 SoC Family	16
3. SIMO Buck Inductor Selection	18
3.1 Overview	18
3.2 Scope	18
3.3 Guidelines.....	18
3.3.1 Apollo510 SoC Family and Apollo330 Plus SoC	18
3.3.2 Apollo3 and Apollo4 SoC Families.....	19
4. BLE Buck Inductor Selection	20
4.1 Overview	20
4.2 Scope	20
4.3 Guidelines.....	20
4.3.1 Apollo510B SoC.....	20
4.3.2 Apollo3 and Apollo4 SoC Families.....	21
5. Apollo510B BLE HW Configuration	22
5.1 Overview	22
5.2 Scope	22
5.3 Guidelines	22
5.3.1 Apollo510B SoC.....	22
6. 32 kHz Crystal Guidelines	29
6.1 Overview	29
6.2 Scope	29
6.3 Guidelines.....	29
6.3.1 Apollo3 and Apollo4 SoC Families.....	29
6.3.2 Apollo510 Family and Apollo330 Plus SoCs.....	30
7. High-Speed Crystal Guidelines	31

7.1 Overview	31
7.2 Scope	31
7.3 Guidelines.....	31
7.3.1 Apollo510 SoC	31
7.3.2 Apollo510B SoC.....	31
7.3.3 Apollo510 Lite and Apollo330 Plus SoCs	32
7.3.4 Apollo4 SoC Family.....	32
7.3.5 Apollo3 SoC Family.....	33
8. External 32 kHz Guidelines	34
8.1 Overview.....	34
8.2 Scope	34
8.3.1 Application Impact	34
8.3.2 Clock Signal and Circuit.....	34
8.3.3 Clock Duty Cycle	36
8.3.4 Register Settings.....	37
9. USB Guidelines	38
9.1 Overview	38
9.2 Scope	38
9.3 Guidelines for Apollo4 and Apollo510 Families and Apollo330 Plus.....	38
9.3.1 USB Unused.....	38
9.3.2 Power Tree	38
9.3.3 ESD Protection and Common-mode Filtering	39
9.3.4 USB VBUS Detection.....	39
9.3.5 VDDUSB33 Current Leakage.....	40
10. MIPI DSI PHY Guidelines	41
10.1 Overview.....	41
10.2 Scope.....	41
10.3 Guidelines for Apollo4 and Apollo510 SoC Families.....	41
10.3.1 Unused	41
10.3.2 Power Tree.....	41
11. MRAM Guidelines.....	42
11.1 Overview.....	42
11.2 Scope.....	42
11.3 Guidelines for Apollo4 and Apollo510 SoC Families and Apollo330 Plus SoC.....	42
12. AUDADC Guidelines	43
12.1 Overview.....	43
12.2 Scope	43
12.3 Guidelines for Apollo4 and Apollo510 SoC Families.....	43

12.3.1 Microphone Bias.....	44
12.3.2 Anti-Aliasing	44
12.3.3 First and Second Order RC Filter Option.....	46
12.3.4 Simulation Values with LTspice.....	47
13. No-Bluetooth Low Energy Guidelines.....	48
13.1 Overview.....	48
13.2 Scope	48
13.3 Guidelines.....	48
13.3.1 Apollo3 SoC Family	48
14. Inductor-less Operation Guidelines.....	49
14.1 Overview.....	49
14.2 Scope	49
14.3 Guidelines.....	49
14.3.1 Apollo3 SoC Family	49
14.3.2 SIMO Buck	49
14.3.3 BLE Buck.....	49
15. Appendix - Review Checklists	51
15.1 Schematic Review Checklist.....	51
15.1.1 Overview.....	51
15.1.2 Scope	51
15.1.3 Guidelines for All SoC Families.....	52
15.2 Layout Review Checklist.....	54
15.2.1 Overview	54
15.2.2 Scope	54
15.2.3 Guidelines for All SoC Families.....	55

List of Tables

Table 1-1: Revision History.....	3
Table 1-2: Reference Documents.....	4
Table 2-1: Apollo510 Recommended Internal Supply and Capacitor Values.....	11
Table 2-2: Apollo510 Recommended External Supply and Capacitor Values.....	12
Table 2-3: Apollo510B Additional External Supplies and Recommended Capacitor Values.....	13
Table 2-4: Apollo510B Additional Internal Supply and Recommended Capacitor Values.....	13
Table 2-5: Apollo510 Lite and Apollo330 Plus Recommended Internal Supply and Capacitor Values.....	13
Table 2-6: Apollo510 Lite and Apollo330 Plus Recommended External Supply and Capacitor Values.....	14
Table 2-7: Apollo4 Recommended Internal Supply and Capacitor Values.....	15
Table 2-8: Apollo4 Recommended External Supply and Capacitor Values.....	16
Table 2-9: Apollo3 Recommended Internal Supply and Capacitor Values.....	16
Table 2-10: Apollo3 Recommended External Supply and Capacitor Values	17
Table 8-1: XTALGENCTRL Register Fields	37
Table 12-1: Frequency Cut off (Fc) Equation	46
Table 12-2: First and Second Order (with Same R and C) Values for a Determined Fc.....	46
Table 15-1: Schematic Review Checklist	52
Table 15-2: Layout Review Checklist	55

List of Figures

Figure 5-1: Extended Circuitry for the BLE Controller in Step-up Power Mode	23
Figure 5-2: External Circuitry for the BLE Controller in Voltage Multiplier Power Mode	23
Figure 5-3: Low-pass Filter between PA and Antenna	24
Figure 5-4: Generic Pi Filter and Antenna Schematic.....	24
Figure 5-5: Apollo510B EVB Filter and Antenna Schematic.....	24
Figure 5-6: Example Layout for the RF Components for the Apollo510B.....	25
Figure 5-7: Cm1 Placement with respect to the RF Antenna (ANT) and Ground Pin (GND)	26
Figure 5-8: Cm1 and Cm2 Placement with respect to the RF (ANT) and Ground Pin (GND)	27
Figure 5-9: Lm1 and Ldc Placement with respect to the RF (ANT) and Ground Pin (GND)	28
Figure 8-1: 32.768 kHz Crystal Clock Circuit Diagram	35
Figure 8-2: CLKOUT Duty Cycle: XI Pin Voltage = 135 mV.....	37
Figure 12-1: Frequency of the Apollo4 Family AUDADC's Anti-Aliasing Filter	44
Figure 12-2: Apollo4 AUDADC Input Circuitry without External Anti-Aliasing Filter Components....	45
Figure 12-3: AUDADC with External Anti-Aliasing Filters.....	46
Figure 14-1: BLE Inductor	50

1. Introduction

This document is a compilation of detailed design guidelines for the Apollo3, Apollo4 and Apollo510 SoC families. Hardware design information for the Apollo510 Lite Series and Apollo330 Plus Series SoCs is now included in this document. Unless specified otherwise, any reference to the Apollo510 family includes the Apollo510 Lite. The Apollo330 Plus is explicitly cited in the text when design information applies to it.

This document is to be used in conjunction with the selected SoC documentation, including the applicable/available datasheet, reference manual, programmer's guide, EVB Quick Start Guide, and errata list. See Reference Documents for a comprehensive list.

2. Voltage Supply Capacitor Guidelines

2.1 Overview

These design guidelines describe the recommended values and types of output and bypass capacitors for the system-on-chip (SoC) voltage supplies.

2.2 Scope

These guidelines are applicable to the Apollo3, Apollo4 and Apollo510 families, as well as the Apollo330 Plus Series SoCs. Consult the current version of the applicable SoC's datasheet for the most up-to-date requirements for bypass capacitors.

2.3 Guidelines

The recommended values and types of capacitors for each family are listed below.

2.3.1 Apollo510 SoC

Table 2-1: Apollo510 Recommended Internal Supply and Capacitor Values

Internal Supply	Capacitor
VDDC, VDDC_LV, VDDS, VDDF	4.7 μ F to ground, 0402 preferred, 0201 acceptable DC Bias (<20% cap drop at 1V) Alternatively, use 10 μ F to have lowest SoC power consumption.
LPADC_VREF	100 nF to ground
LPMICBIAS	2.2 μ F to ground (a smaller value is acceptable if current is less than 400 μ A).

NOTES:

- 6.3 V/X5R caps are recommended for these internal rails.
- The 0201 Murata GRM035R60J475ME15D is used on Ambiq Evaluation Board.
- Consult the current version of the Apollo510 Datasheet for the most up-to-date requirements for bypass capacitors of the internal (SIMO Buck) supplies.

Table 2-2: Apollo510 Recommended External Supply and Capacitor Values

External Supply	Capacitor
VDDP	10 μ F to ground
VDDA	1 μ F to ground
VDDH, VDDH1, VDDH2, VDDH5	2.2 μ F to ground
VDDH3, VDDH4	4.7 μ F to ground
VDDAUDA	2.2 μ F to ground (typical); see notes 4, 5 and 6 below
VDDUSB33	2.2 μ F to ground
VDDUSB0P9	2.2 μ F to ground
VDD18	2.2 μ F to ground

NOTES:

1. Recommend use of 5 V or greater caps for 1.8 V rails.
2. Recommend use of 10 V caps for 3.3 V rails.
3. VDDAUDA supplies power to both AUDADC and the high-speed crystal oscillator circuit. Care must be taken when selecting an appropriate power supply.
4. Consult the current version of the Apollo510 Datasheet for the most up-to-date requirements for bypass capacitors and required sequencing and/or termination of external supplies.
5. Follow recommendations for LDO suppliers.
6. For 1.2 V supply, the minimum voltage (including ripple) is 1.12 V.
7. Suitable standalone small factor LDOs:
 - a. Microchip MCP1811A in 1.0 x 1.0 x 0.5 mm UDFN package
 - b. TI TPS7A02 in 1.0 x 1.0 x 0.4 mm X2SON package

2.3.2 Apollo510B SoC

The Apollo510B has the same recommended internal supply and capacitor values as the Apollo510 mentioned above in addition to the VBAT1 supply. For the suggested capacitor value on VBAT1, refer to Table 2-4 below.

The Apollo510B has the following additional external supply rails compared to the Apollo510. In addition, VDDH5 is not exposed on the Apollo510B package. Also, the recommended VDDH4 capacitance is smaller than that needed on the Apollo510 due to lack of exposed VDDH4 GPIO on the Apollo510B package. These are shown in the table below.

Table 2-3: Apollo510B Additional External Supplies and Recommended Capacitor Values

External Supply	Capacitor
VIO	100 nF to ground
VCC	2.2 μ F to ground
VBAT2	1 μ F to ground
VDDH4	0.1 μ F to ground
VDDH5	Not Used

Table 2-4: Apollo510B Additional Internal Supply and Recommended Capacitor Values

Internal Supply	Capacitor
VBAT1	2.2 μ F to ground

NOTES:

- Recommended components:
 - CVIO: Murata GRM155R62A104KE14D (0402)
 - CVCC: Murata GRM155R61C225KE11D (0402)
 - CVBAT1: Murata GRM155R61C225KE11D (0402)
 - CVBAT2: Murata GRM155R61C105MA12D (0402)
- The following 0201 components may be used instead of the above 0402 set for a small efficiency penalty if there are space constraints:
 - CVIO: Murata GRM033Z71C104KE14D (0201)
 - CVCC: Murata GRM035R61C225ME01D (0201)
 - CVBAT2: Murata GRM033R61C105ME15D (0201)
- CVCC is optional in both BLE operating modes of the Apollo510B (Step-Up and Voltage Multiplier) and can be omitted.
- It is strongly recommended to use a capacitor with specifications similar to or better than GRM155R61C225KE11D (0402) for the VBAT1 capacitor.

2.3.3 Apollo510 Lite and Apollo330 Plus SoCs

The Apollo510 Lite and the Apollo330 Plus SoCs have the recommended internal supply and capacitor values as listed in Table 2-5 below.

Table 2-5: Apollo510 Lite and Apollo330 Plus Recommended Internal Supply and Capacitor Values

Internal Supply	Capacitor
VDDC, VDDC_LV, VDDS, VDDF, VDDRF	4.7 μ F / 10 μ F to ground, 0402 preferred, 0201 acceptable
VDD0P9	2.2 μ F to ground

NOTES:

For Internal Supply capacitors on VDDC, VDDC_LV, VDDS, VDDF, VDDRF, the following specifications should be followed:

- Smaller package option: 4.7 μF , $\pm 20\%$, 6.3 V, X5R, $-55^\circ\text{C} \sim 85^\circ\text{C}$, 0201, ceramic.
- Larger package option for up to 2% reduction in total power over smaller package: 10 μF , $\pm 20\%$, 10 V, X5R, $-55^\circ\text{C} \sim 85^\circ\text{C}$, 0402, ceramic.
- Both 0402 and 0201 packages need to be placed as close to the MCU pins as possible in the bullet below.
- No more than 20% reduction in capacitance with a DC bias of 0.9 V.
- Recommended parts:
 - 4.7 μF : Murata GRM035R60J475ME15 or equivalent
 - 10 μF : Murata GRT155R61A106ME13J or equivalent

Table 2-6: Apollo510 Lite and Apollo330 Plus Recommended External Supply and Capacitor Values

External Supply	Capacitor
VDDP	10 μF to ground
VDDA	1 μF to ground
VDDH, VDDH1, VDDH2, VDDH5	2.2 μF to ground
VDDH3, VDDH4	4.7 μF to ground
VDDUSB33	2.2 μF to ground
VDDUSB0P9	2.2 μF to ground
VDDRF_H	4.7 μF to ground, plus 10 nF high frequency filtering capacitor
VDDRF_PAH	10 μF to ground, plus 10 nF high frequency filtering capacitor
VDDRF_TRX	4.7 μF to ground, plus 10 nF high frequency filtering capacitor
VDD18	2.2 μF to ground

NOTES:

1. For VDDH3 and VDDH4, it might be possible to use a bypass capacitor smaller than 4.7 μF (possibly 2.2 μF) depending on the speed of the external LDO and how close the LDO is placed to the Apollo510 Lite or Apollo330 Plus device and external PSRAM power pins, and the interface speed being used. It is also recommended that the same size bypass capacitor be used for the I/O supply of the external (PSRAM) device.
2. For VDDP 10 μF : Recommend 0402 package, 10 V. No more than 40%

reduction in capacitance (6.0 μF) with a DC bias of 1.8 V. Suitable component: CL05A106MP8NUB8.

3. Recommend use of 5 V or greater capacitors for 1.9 V rails.
4. Recommend use of 10 V capacitors for 3.3 V rails.
5. Do not float any supply input. If a supply is not used, it should be tied to a supply within its operating range.
6. With the preconditions that HP mode and GPU are not used, Tx power is limited to ≤ 4 dBm, and VDDC, VDDC_LV, VDDF, VDDS and VDDRF capacitors are 4.7 μF / 6.3 V / X5R / 0201 (e.g., <https://www.digikey.com/en/products/detail/murata-electronics/GRM035R60J475ME15J/10699045?msocid=39be6f620b1868a53b727b560ab96914>), then the following capacitor characteristics can be used:
 - VDDRF_H, VDDRF_PAH, and VDDRF_TRX high frequency filtering capacitors should be 10 nF / 6.3 V with size 0201.
 - VDDRF_H, VDDRF_PAH, and VDDRF_TRX bulk capacitors should be size 0201 with the following values:
 - VDDRF_TRX is a 4.7 μF / 6.3 V capacitor.
 - VDDRF_H is a 4.7 μF / 6.3 V capacitor but could be 2.2 μF with a change to the value of the high frequency filtering capacitor (TBD).
 - VDDRF_PAH is a 10 μF / 4 V capacitor.
7. Suitable standalone small form factor LDOs:
 - Microchip MCP1811A in 1.0 x 1.0 x 0.50 mm UDFN package
 - TI TPS7A02 in 1.0 x 1.0 x 0.40 mm X2SON package
8. VDD18 only exists on Apollo510 Lite and is a no-connect (NC) on Apollo330 Plus SoC.

2.3.4 Apollo4 SoC Family

Table 2-7: Apollo4 Recommended Internal Supply and Capacitor Values

Internal Supply	Capacitor
VDDC, VDDC_LV, VDDS	2.2 μF to ground
VDDF	2.2 μF to ground, 2.2 μF to VDDP
LPADC_VREF	100 nF to ground
VDDBH	4.7 μF to ground
VDDBH_RF	1 μF to ground

NOTES:

1. 0201, 2.2 μ F, 10 V, X5R caps are recommended for these internal rails.
2. Murata GRM033R61A225KE47D used on Ambiq Evaluation Boards.
3. See Apollo4 Errata ERR087 for details on VDDF to VDDP capacitor.
4. Consult the current version of the applicable Apollo4 datasheet for the most up-to-date requirements for bypass capacitors of the internal (SIMO Buck) supplies.

Table 2-8: Apollo4 Recommended External Supply and Capacitor Values

External Supply	Capacitor
VDDP, VDDH, VDDH2, VDDA	1 μ F to ground
VDDAUDD	2.2 μ F to ground
VDDAUDA	2.2 μ F to ground (typical); see notes 4, 5 and 6 below
VDDUSB33	2.2 μ F to ground
VDDUSB0P9	2.2 μ F to ground
VDD18	2.2 μ F to ground
VDDB	2.2 μ F to ground

NOTES:

1. Recommend use of 5 V or greater caps for 1.9 V rails.
2. Recommend use of 10 V caps for 3.3 V rails.
3. Consult the current version of the applicable Apollo4 datasheet for the most up-to-date requirements for bypass capacitors and required sequencing and/or termination of external supplies.
4. VDDAUDA supplies power to both the AUDADC and the high-speed crystal oscillator circuit, and care must be taken for selecting an appropriate power supply. Refer to the *Apollo4 SoC Datasheet* and refer to the *Electrical Characteristics* section for details.
5. Follow recommendations of LDO supplier.
6. Suitable standalone small form factor LDOs:
 - a. Microchip MCP1811A in 1.0 x 1.0 x 0.50 mm UDFN package

2.3.5 Apollo3 SoC Family

Table 2-9: Apollo3 Recommended Internal Supply and Capacitor Values

Internal Supply	Capacitor
VDDC, VDDS	2.2 μ F to ground
VDDF	2.2 μ F to ground 1.5 - 2.2 μ F to VDDP
ADC_VREF	470 nF to ground
VDDBH	4.7 μ F to ground

VDCDCRF	1 μ F to ground
DVDD	47 nF to ground

NOTES:

1. 0201, 2.2 μ F, 10 V, X5R caps are recommended for these internal rails.
2. Murata GRM033R61A225KE47D used on Ambiq Evaluation Boards.
3. See Apollo3 Errata ERR029 for details on VDDF to VDDP capacitor.

Table 2-10: Apollo3 Recommended External Supply and Capacitor Values

External Supply	Capacitor
VDDP, VDDH, VDDA, VCC	1 μ F to ground
Vddb	2.2 μ F to ground

NOTES:

1. Recommend use of 5 V or greater caps for 1.8 V rails.
2. Recommend use of 10 V caps for rails above 1.8 V.

3. SIMO Buck Inductor Selection

3.1 Overview

These guidelines describe the recommended inductor used for the SIMO Buck.

3.2 Scope

These guidelines apply to Apollo3, Apollo4 and Apollo510 SoC families and the Apollo330 Plus Series SoCs.

3.3 Guidelines

The recommended SIMO Buck inductor selection guidelines used for each family should have the following characteristics.

3.3.1 Apollo510 SoC Family and Apollo330 Plus SoC

The recommended SIMO Buck inductor for the Apollo510 SoC family should have the following characteristics:

- Inductance: 2.2 μ H
- Saturation current: >1A
- Maximum DC resistance: < 0.55 Ω
- Operating frequency range: > 20 MHz
- Recommended parts:
 - Murata Manufacturing DFE201210U-2R2M=P2
 - Taiyo Yuden LSCND1608HKT2R2MF
- Q-Factor between 2 and 10 MHz should be as high as possible for lowest overall SoC power consumption, ideally no less than 20 within the range.

Consult the current version of the SoC Datasheet for the most up-to-date requirements for SIMO Buck Inductor requirements and part options.

3.3.2 Apollo3 and Apollo4 SoC Families

The recommended SIMO Buck inductor for the Apollo4 and Apollo3 families should have the following characteristics:

- Apollo3 and Apollo4: 2.2 μ H
- Saturation current > 400 mA (> 500 mA preferred)
- Maximum DC resistance < 0.55 Ω
- Operating frequency range > 20 MHz
- Recommended parts:
 - Murata DFE201610E-2R2M=P2 (0806)
 - Taiyo Yuden MBKK1608T2R2M (0603)

It is recommended to use the highest saturation current inductor that can meet the board space constraints and cost targets for a particular application, as higher saturation current improves overall system efficiency.

4. BLE Buck Inductor Selection

4.1 Overview

These design guidelines describe the recommended inductor used for the BLE Buck inductor for the Apollo3 and Apollo4 families as well as the Apollo510B SoC. This section does not apply to Apollo510 Lite series or Apollo330 Plus series SoCs.

4.2 Scope

These guidelines apply to the Apollo3 and Apollo4 SoC families as well as the Apollo510B SoC.

4.3 Guidelines

The recommended BLE Buck inductor for each family of SoCs should have the following characteristics.

4.3.1 Apollo510B SoC

The recommended BLE DC-DC Buck inductor for the Apollo510B SoC should either be 4.7 μH or 2.2 μH for a reduced PCB footprint. This inductor is only used in the Step-up mode of the BLE. For more information about the BLE Buck inductor, refer to the “Components for the BLE Controller” section of the Apollo510B Datasheet.

- Recommended part:
 - Murata LQM18PN4R7MFRL (4.7 μH - 0603)
 - TDK MLZ1005M2R2WT000 (2.2 μH - 0402)

4.3.2 Apollo3 and Apollo4 SoC Families

The recommended BLE Buck inductor for the Apollo3 and Apollo4 families should have the following characteristics:

- 1 μ H
- Saturation current > 800 mA
- Maximum DC resistance < 0.55 Ω
- Operating frequency range > 20 MHz
- Recommended part:
- Murata DFE18SAN1R0ME0 (0603)

5. Apollo510B BLE HW Configuration

5.1 Overview

These design guidelines describe the BLE Controller hardware configurations.

5.2 Scope

These guidelines apply to the Apollo510B SoC only.

5.3 Guidelines

The hardware configurations used for the Apollo510B BLE should conform to the following recommended guidelines.

5.3.1 Apollo510B SoC

BLE Controller Power Mode Selection

There are 2 modes for the Apollo510B BLE Controller - Voltage Multiplier Power mode and Step-up Power mode. The recommended BLE controller circuitry and components for each of these modes are shown below.

Figure 5-1: Extended Circuitry for the BLE Controller in Step-up Power Mode

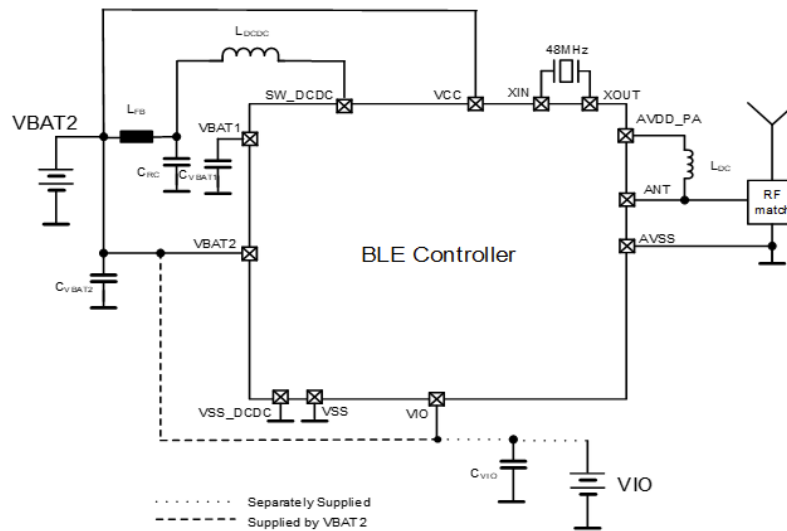
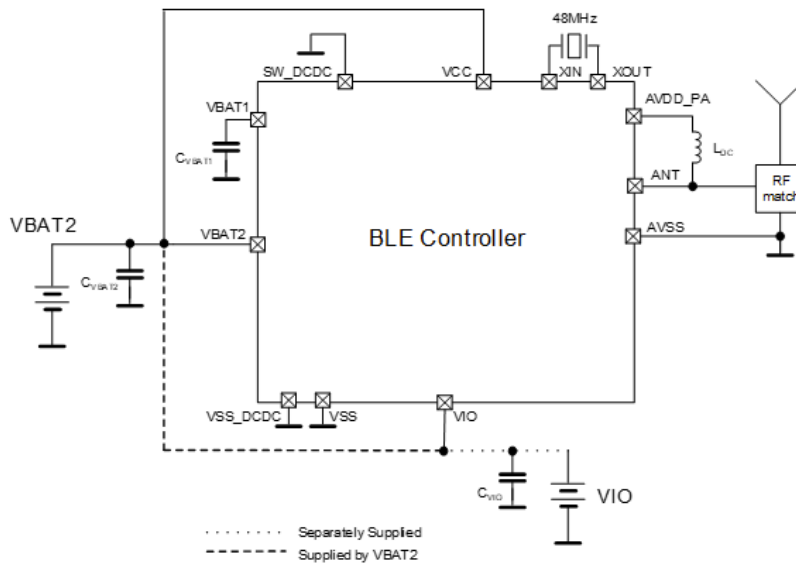

Figure 5-2: External Circuitry for the BLE Controller in Voltage Multiplier Power Mode



Please refer to the “Components for the BLE Controller” section of the Apollo510B datasheet for a list of recommended BLEC external components.

RF Matching Network and Antenna Design

This section provides guidance for designing a pi filter which functions as both the impedance matching circuit and the low-pass filter to connect the Apollo510B to an arbitrary antenna.

For the radio to operate efficiently, the impedance of the antenna must be transformed to match the optimal load impedance of the Apollo510B. Additionally, it is common to implement a low-pass filter between the PA and antenna for the purpose of reducing unwanted out-of-band emissions.

Figure 5-3: Low-pass Filter between PA and Antenna

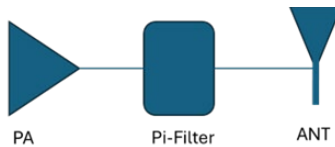

For Apollo510B, the implementation of the above system diagram can be represented by the following generic schematic.

Figure 5-4: Generic Pi Filter and Antenna Schematic

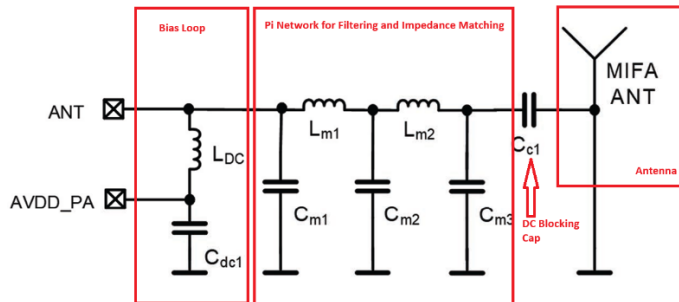

The following image shows this implementation on the Apollo510B EVB.

Figure 5-5: Apollo510B EVB Filter and Antenna Schematic

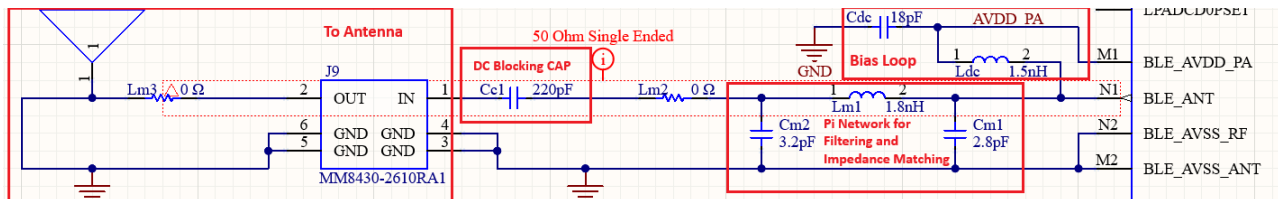

Please refer to the “Components for the BLE Controller” section in the Apollo510B datasheet for a list of recommended RF matching network components.

RF Matching Component Placement

The following guidelines should be followed for the layout and RF matching component placement for the Apollo510B.

Figure 5-6: Example Layout for the RF Components for the Apollo510B

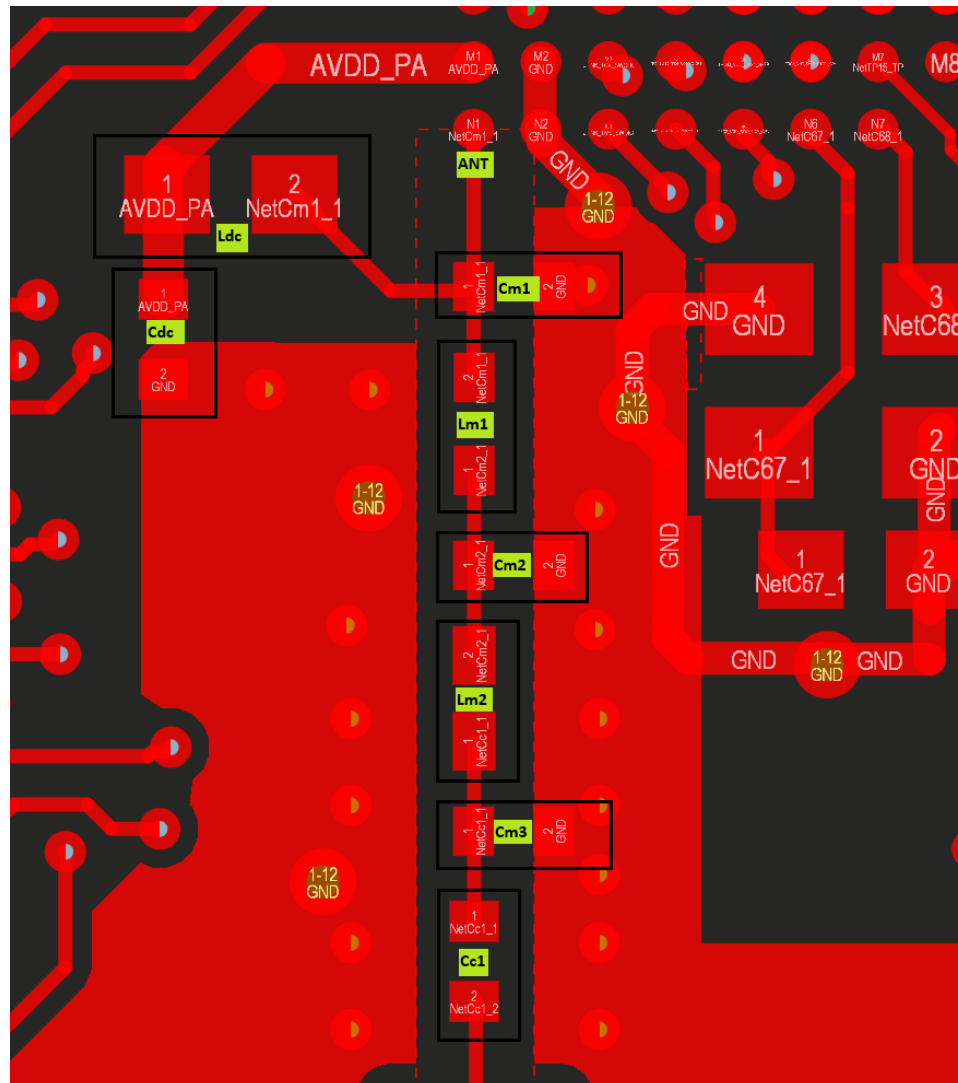

- Placement of Cm1 is critical for control of harmonics and needs to be placed as close to the ANT pin and the connection to the Apollo510B GND pin as shown in the figure below.

Figure 5-7: Cm1 Placement with respect to the RF Antenna (ANT) and Ground Pin (GND)

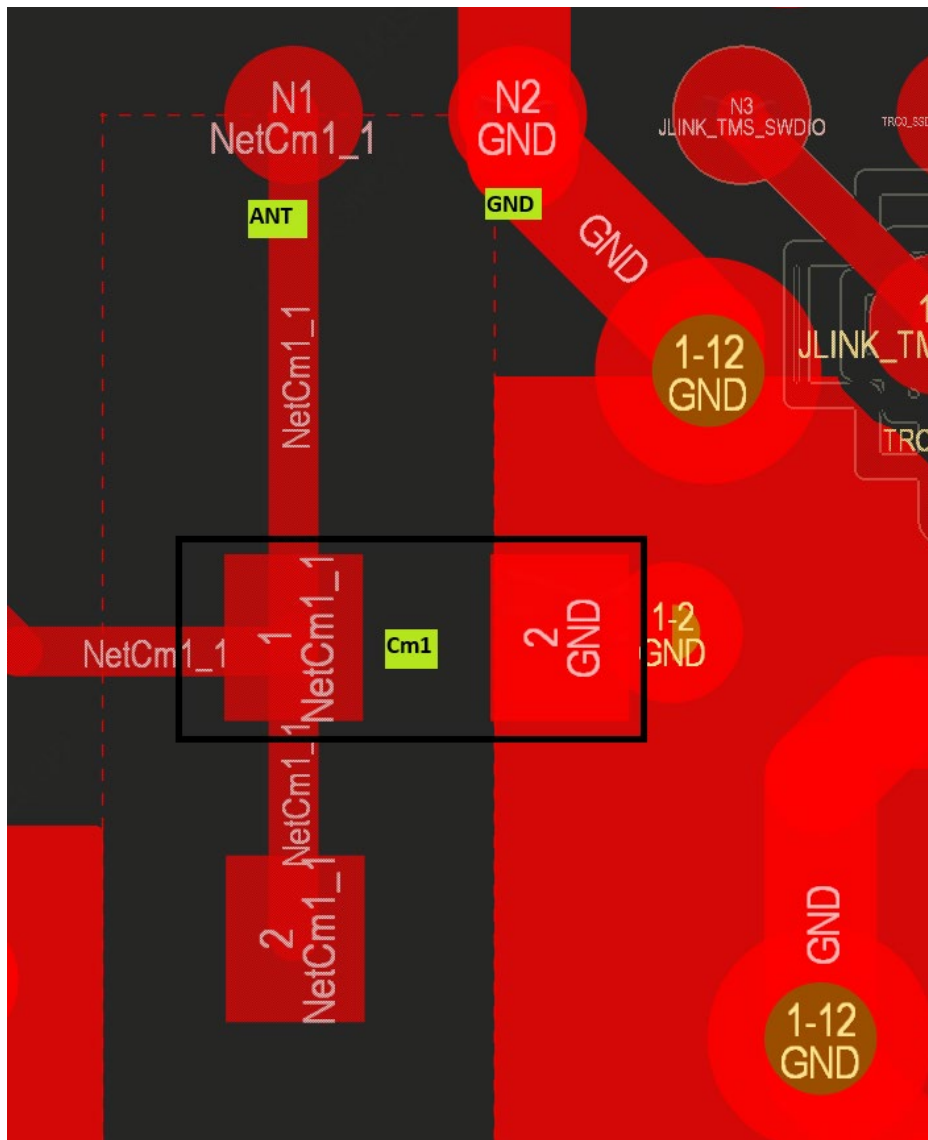

The ground side of shunt capacitors Cm1 and Cm2 must be placed on the same side as the GND reference pin of the Apollo510B to preserve the correct current path.

Figure 5-8: Cm1 and Cm2 Placement with respect to the RF (ANT) and Ground Pin (GND)

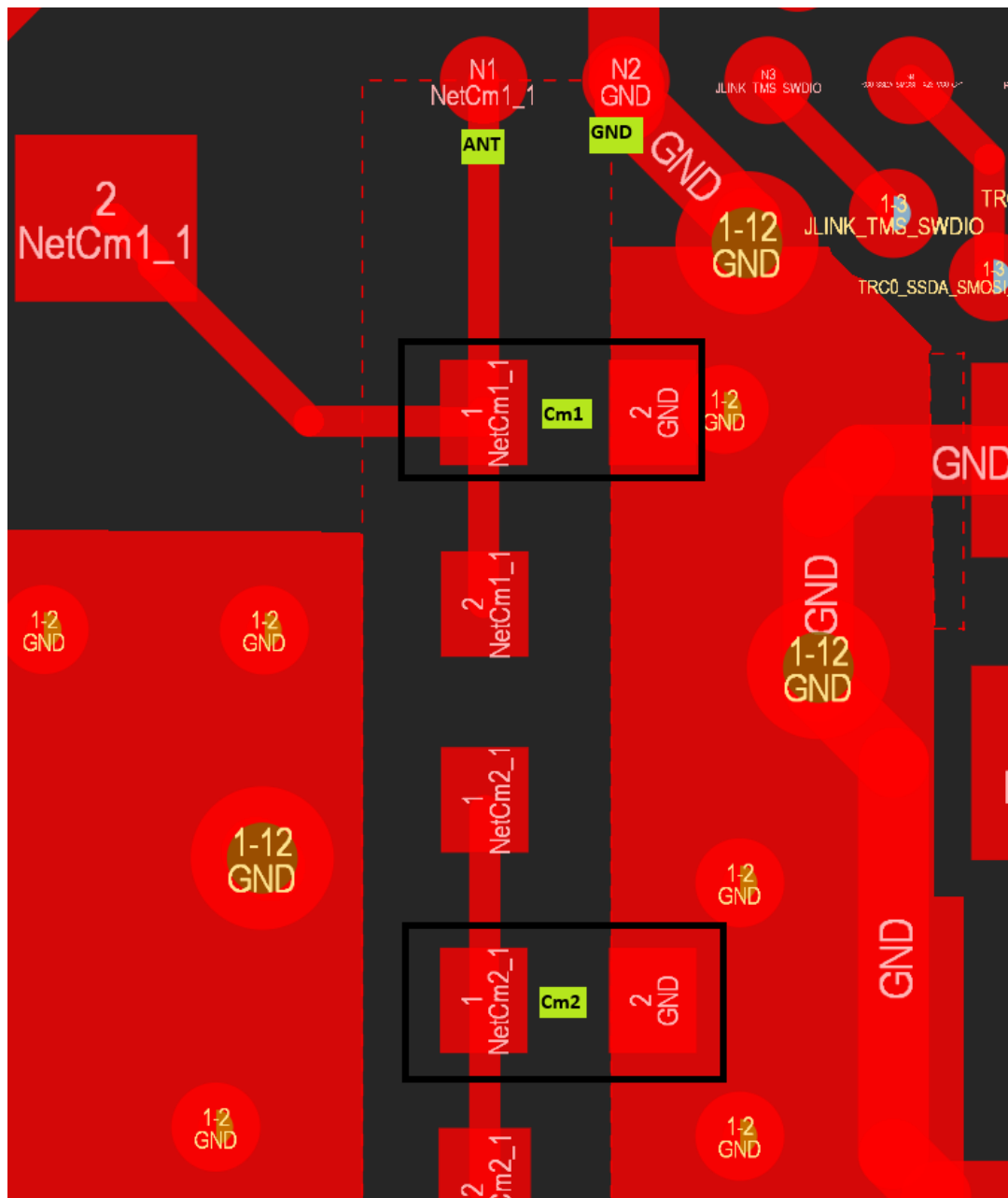

- Avoid routing the RF path through angles greater than 45 degrees. Avoid all stubs on the RF path.
- Parasitic series inductance (PCB trace) added before or after a shunt capacitor will cancel the capacitance. Therefore, Cm1 and Cm2 capacitors should be in line with the antenna feed, not connected with stubs to the feed or ground.
- Place Lm1 & Ldc perpendicular to one another and separate the components by at least 1mm, as shown in the figure below.

Figure 5-9: Lm1 and Ldc Placement with respect to the RF (ANT) and Ground Pin (GND)

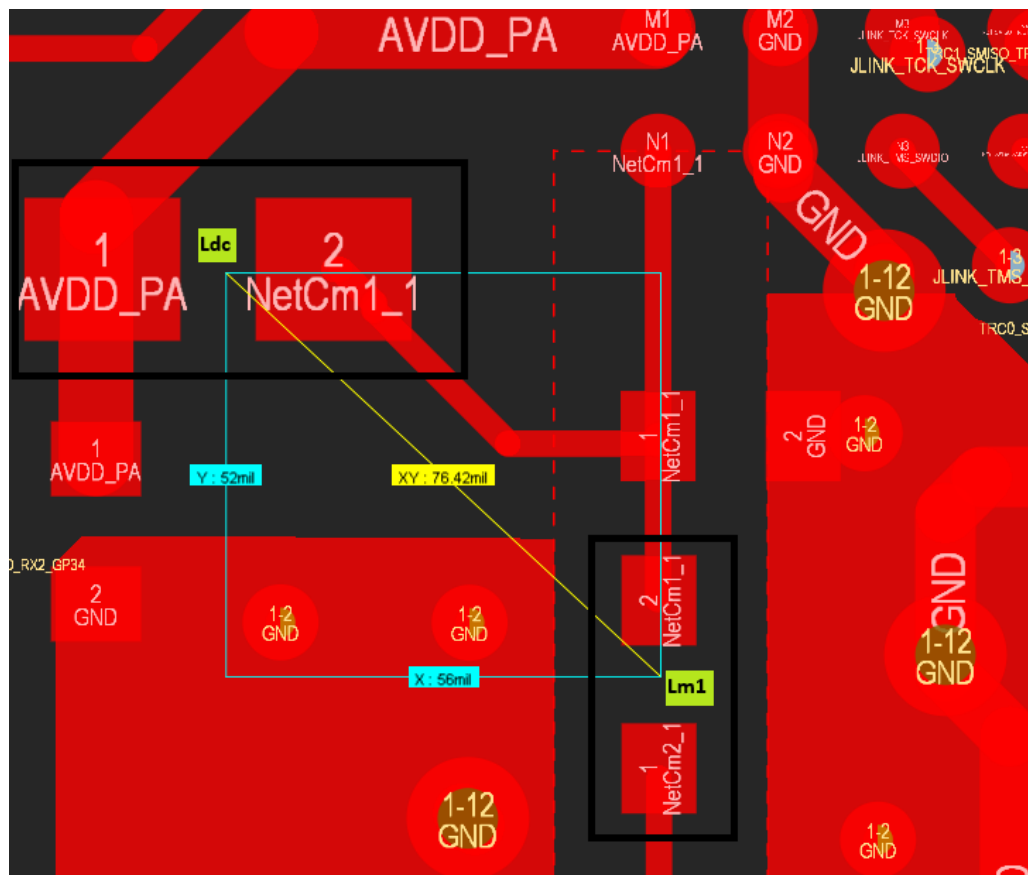

Please refer to the Apollo510B EVB Design Files for complete layout and antenna design.

6. 32 kHz Crystal Guidelines

6.1 Overview

These design guidelines describe the recommended components for the 32 kHz XTAL circuit.

6.2 Scope

These guidelines apply to the Apollo3, Apollo4, Apollo510 families and Apollo330 Plus Series SoCs.

6.3 Guidelines

The recommended 32 kHz crystal circuit components used for each family should have the following characteristics.

6.3.1 Apollo3 and Apollo4 SoC Families

With the 7 pF maximum pin per load capacitance, it is recommended to choose a crystal with a capacitive loading specification of 7 pF or less. Use of a lower load capacitance leads to better power efficiency and, as a result, it is recommended to pick a crystal rated for 4 pF. The Apollo3 and Apollo4 evaluation boards can be referenced for example selections at the lower (3 pF for Apollo3 Blue Plus) and higher (7 pF for Apollo4 Plus) load ranges. Note that the XI and XO pins form an oscillator circuit that has low bias current to get extremely low power consumption. Therefore, the user's design should ensure that the leakage current on the XI and XO pins is 1 nA or less. Given the low capacitance of loading capacitors, this is not likely to be an issue with component selection, but users should give special consideration to this area of design to ensure parasitic leakages are minimized.

- Apollo510 Evaluation Boards use 9HT12-32.768KDZY
- Apollo4 Evaluation Boards use 9HT12-32.768KDZY
- Apollo3 Evaluation Boards use ABS06W-32.768KHZ-D-2-T

6.3.2 Apollo510 Family and Apollo330 Plus Series SoCs

With the 10 pF maximum pin per load capacitance, it is recommended to choose a crystal with a capacitive loading specification of 10 pF or less. The high accuracy XTAL Oscillator is tuned to an external 32.768 kHz crystal and has a nominal frequency of 32.768 kHz. It is used when frequency accuracy is critically important. To minimize power consumption, the XTAL is only enabled when an internal module is using it. It should be noted that the XTAL oscillator is also optional if the requirements of the design can tolerate the internal LFRC/HFRC oscillator specifications.

The XTAL is highly sensitive to external leakage on the XI pin. Therefore, it is recommended to minimize the components on XI and to use extremely low leakage load capacitors.

7. High-Speed Crystal Guidelines

7.1 Overview

These design guidelines describe the recommended characteristics of the high-speed crystal used for each SoC family.

7.2 Scope

These guidelines apply to the Apollo3, Apollo4, Apollo510 families and Apollo330 Plus Series SoCs.

7.3 Guidelines

The high-speed crystal characteristics for each family should have the following characteristics.

7.3.1 Apollo510 SoC

The Apollo510 high-speed crystal circuitry is designed to work with 24, 32 or 48 MHz crystals specified with a load capacitance of 6 pF, a maximum ESR of 100 Ω , and a maximum of ± 40 PPM including initial tolerance, aging and temperature drift. Ambiq recommends choosing a crystal with tighter tolerance to account for board-to-board load capacitance variation.

Load capacitors are integrated within the Apollo510, but Ambiq recommends additional load capacitor pads be made available on the PCB design, should additional tuning be required. For the Apollo510 SoC Family, using lower than specified load capacitance could result in lower XTAL frequency. Using higher capacitance than the specified value may lead to insufficient frequency trim range.

The Apollo510 EVB uses a 48 MHz Abracon crystal, P/N ABM12W-48.0000MHZ-6-D1X-T3. Recommended crystals for alternative frequencies are the following:

- For 32 MHz: Abracon P/N ABM12W-32.0000MHZ-6-D1X-T3
- For 24 MHz: Abracon P/N ABM12W-24.0000MHZ-6-D1X-T3

7.3.2 Apollo510B SoC

The Apollo510B high-speed crystal circuitry is designed to work with a 48 MHz crystal specified with a load capacitance of 8 pF to 11 pF (with a typical value of 10pF), a maximum ESR of 60 Ω , and a maximum of ± 50 PPM including initial tolerance, aging and temperature drift. Ambiq recommends choosing a crystal with tighter tolerance to account for board-to-board load capacitance

variation.

Load capacitors are integrated within the Apollo510B, but Ambiq recommends additional load capacitor pads be made available on the PCB design, should additional tuning be required. For the Apollo510B SoC, using lower than specified load capacitance could result in lower XTAL frequency. Using higher capacitance than the specified value may lead to insufficient frequency trim range.

The Apollo510B EVB uses a 48 MHz CS10127-48M Crystal from NDK. As an alternative, ETSB48E007502E from Hosonic Electronics or a crystal with similar specs can also be used.

7.3.3 Apollo510 Lite and Apollo330 Plus SoCs

The Apollo510 Lite and Apollo330 Plus high-speed crystal circuitry is designed to work with a 48 MHz crystal specified with a typical load capacitance of 6 pF, a maximum ESR of 100 Ω , and a maximum of ± 40 PPM including initial tolerance, aging and temperature drift. Ambiq recommends choosing a crystal with tighter tolerance to account for board-to-board load capacitance variation.

Load capacitors are integrated within the Apollo510 Lite and Apollo330 Plus, but Ambiq recommends additional load capacitor pads be made available on the PCB design, should additional tuning be required. Using lower than specified load capacitance could result in lower XTAL frequency. Using higher capacitance than the specified value may lead to insufficient frequency trim range.

The Apollo510 Lite and Apollo330 Plus EVBs use a 48 MHz ABM12W-48.0000MHZ-6-D1X-T3 Crystal from Abracon. As an alternative, a crystal with similar specs can also be used.

7.3.4 Apollo4 SoC Family

The Apollo4 32 MHz XTAL circuitry is designed to work with crystals specified for 6 pF of load capacitance, a maximum ESR of 100 Ω , and a maximum of ± 40 PPM including initial tolerance/aging/temperature drift. It is recommended to choose a crystal with tighter tolerance to account for board-to-board load capacitance variation.

Load capacitors are integrated within the Apollo4, but it is recommended to keep pads available on the PCB design in case additional tuning is required. These capacitor pads do not have to be populated.

For both the Apollo3 and Apollo4 Families, using lower than specified load capacitance could result in lower XTAL frequency. Higher capacitance than the

specified value may lead to insufficient frequency trim range.

For details on calibrating the 32 MHz crystal, please see the following knowledgebase article: [Apollo4 Blue / Apollo4 Blue Plus SoC 32 MHz Crystal Calibration – Ambiq Support](#).

The Apollo4 EVBs use a 32 MHz Abracon crystal, P/N ABM12W-32.0000MHZ-6-D1X-T3.

7.3.5 Apollo3 SoC Family

The Apollo3 32 MHz XTAL circuitry is designed to work with crystals specified for 8 pF load capacitance, a maximum ESR of 100 Ω , and a maximum of ± 40 PPM including initial tolerance/aging/temperature drift. It is recommended to choose a crystal with tighter tolerance to account for board-to-board load capacitance variation.

Load capacitors are integrated within the Apollo3, but it is recommended to keep pads available on the PCB design in case additional tuning is required. These capacitor pads do not have to be populated.

For details on calibrating the 32 MHz crystal, please see the following Knowledgebase article: [Apollo3 Blue SoC 32 MHz Crystal Calibration – Ambiq Support](#).

The Apollo3 EVBs use a 32 MHz ECS crystal, P/N 520-ECS-320-8-47JTNT.

8. External 32 kHz Guidelines

8.1 Overview

These design guidelines describe the recommended external circuit components and SoC pins required to supply an external 32.768 kHz clock to an Apollo3 or Apollo2 SoC, and for connecting the oscillator source and sizing the signal properly.

NOTE: The use of an external 32.768 kHz clock as the low frequency clock reference on the Apollo510 family and the Apollo330 Plus Series SoCs is described in the Clock Generation and Control chapter of the *Apollo5 Family SoCs Reference Manual*.

8.2 Scope

These guidelines apply only to all versions and packages of the Apollo3 Blue SoC as well as Apollo2 and Apollo2 Blue SoCs.

8.3 Guidelines for Apollo3 and Apollo2 SoC Families

Due to design requirements, some customers prefer to use an external oscillator (XO) device, or a temperature-controlled external oscillator (TCXO) as a replacement for the 32.768 kHz crystal. The Apollo SoC's crystal oscillator can be adapted to work with an external clock fed into the Apollo's XO pin. There are two requirements to enable external clocking of the SoC - an acceptable clock signal/circuit and correct register configuration.

8.3.1 Application Impact

Following these recommendations ensures that the Apollo2 and Apollo3 families of SoCs are clocked reliably and safely with an external clock source.

8.3.2 Clock Signal and Circuit

The crystal-controlled oscillator circuit requires a clock input which meets a specific range of frequency, amplitude and duty cycle. Figure 8-1 shows the recommended circuit diagram, components, and SoC pin connections using a 32.768 kHz external clock (32K_EXTCLK) with peak-to-peak voltage variation allowance from 1.5 V to 3.6 V.

Figure 8-1: 32.768 kHz Crystal Clock Circuit Diagram

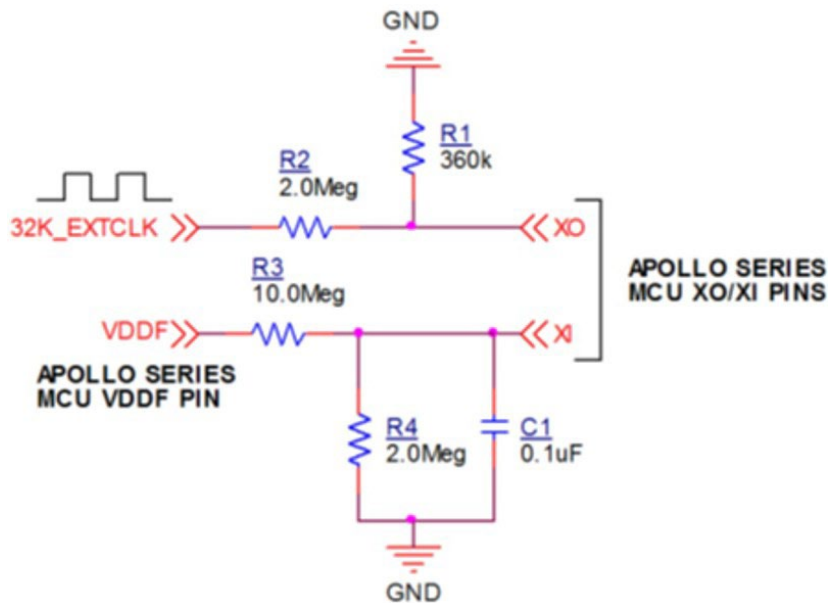

The recommended circuit must meet the following requirements:

- 32K_EXTCLK signal:
 - Frequency range: 32.768 kHz external clock source $\pm 10\%$ (29.491 - 36.044 kHz). Operation at any frequency above or below this range is not guaranteed.
 - Duty cycle: 45% - 55%
 - Amplitude (V_{min} to V_{max} peak-to-peak): $V_{min} = 0$ V to 0.2 V and $V_{max} = 1.5$ V to 3.6 V
- C1 capacitor:
 - Tolerance: 30%
- R1, R2, R3, R4 resistors:
 - Tolerance: 10%
 - R3, R4 values cannot be changed if this resistor divider is powered from VDDF
 - R2 value must be between 100 k Ω – 2.0 M Ω .
 - R1, R2 values can be adjusted as long as the XO pin voltage requirements below are met.

- XO pin voltage requirements:
 - Voltage input low range: 0 – 35 mV
 - Voltage input peak-to-peak: 340 mV (nominal)
 - Voltage input high range: 260 mV – 440 mV (recommended); 230 mV – 600 mV (acceptable)
- XI pin voltage requirements:
 - Nominal: 130 mV
 - Maximum: 155 mV
 - Minimum: 105 mV
 - Maximum ripple: 10 mV

The 32 kHz clock source, 32K_EXTCLK, should be located as close to the XO pin as possible and be routed away from high-switching signals. Trace length should be minimized such that total capacitive load (board + chip pad capacitance) on the XO net should not exceed 5 pF.

NOTE: The user/designer needs to be very careful when probing the net containing the XO pin (output of the resistor divider) and must use a FET probe or similar with ultra-high input impedance (10 M Ω or greater) and very low capacitance (1 pF or less).

8.3.3 Clock Duty Cycle

The chart below shows the CLKOUT duty cycle variation versus XO pin peak-to-peak voltage for 32K_EXTCLK input duty cycles of 45%, 50% and 55% with an XI pin bias voltage of 135 mV. Under typical conditions, an XO pin peak-to-peak voltage of 340 mV will produce a nominal 50% CLKOUT duty cycle with a 50% 32K_EXTCLK input duty cycle.

Figure 8-2: CLKOUT Duty Cycle: XI Pin Voltage = 135 mV

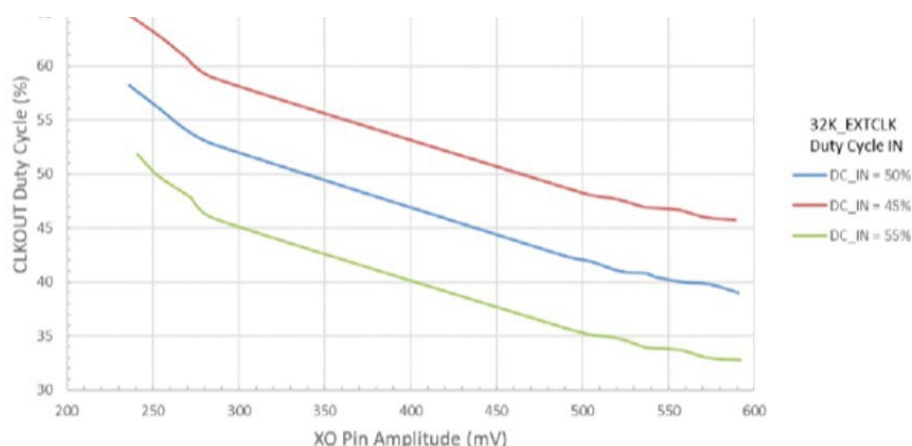

8.3.4 Register Settings

The XTALBIASTRIM and the XTALKSBIASTRIM fields in the XTAL Oscillator General Control register (MCUCTRL_XTALGENCTRL), located at address 0x40020124, must set the crystal bias current and the crystal bias kick start current, respectively, to the minimum setting. The XTALGENCTRL register fields are as shown in the register table below.

Table 8-1: XTALGENCTRL Register Fields

Bit	Name	Reset	RW	Description
31:14	RSVD	0x0	RO	RESERVED.
13:8	XTALKSBIASTRIM	0x1	RW	XTAL IBIAS Kick start trim. This trim value is used during the startup process to enable a faster lock.
7:2	XTALBIASTRIM	0x0	RW	XTAL BIAS trim
1:0	ACWARMUP	0x0	RW	Auto-calibration delay control SEC1 = 0x0 - Warmup period of 1-2 seconds SEC2 = 0x1 - Warmup period of 2-4 seconds SEC4 = 0x2 - Warmup period of 4-8 seconds SEC8 = 0x3 - Warmup period of 8-16 seconds

The XTALBIASTRIM and XTALKSBIASTRIM fields must be set to a value of 0 for the Apollo3 family of SoCs and 32 (decimal) for the Apollo2 and Apollo2 Blue SoCs.

9. USB Guidelines

9.1 Overview

These design guidelines describe the USB hardware design considerations for the Apollo4 and Apollo510 SoC family as well as the Apollo330 Plus Series. For full and up-to-date details on proper power sequencing and other system use considerations, consult the applicable SoC datasheet.

9.2 Scope

These guidelines apply to the Apollo4 family, Apollo510 family and the Apollo330 Plus Series SoCs.

9.3 Guidelines for Apollo4 and Apollo510 Families and Apollo330 Plus

Below are several design guidelines which should be followed for proper USB operation.

9.3.1 USB Unused

If the USB peripheral is not used, please leave the USB data pads, USB0PP and USB0PN, floating and connect the USB PHY power rails, VDDUSB33 and VDDUSB0P9, to ground.

9.3.2 Power Tree

For designs utilizing the USB peripheral, the following power tree is recommended:

1. VDDUSB33 and VDDUSB0P9 should be powered by an LDO with output

discharge and ON/OFF control over I²C or GPIO. It is recommended to source VDDUSB33 and VDDUSB0P9 power from USB VBUS to minimize system power consumption from the battery. The following devices are examples of suitable standalone, small form-factor LDOs:

- a. ST Micro LDBL20 in 0.47 x 0.47 x 0.22 mm STSTAMP™ package
 - b. ST Micro LD39130S in 0.69 x 0.69 x 0.5 mm CSP package
 - c. TI LP5910 0.74 x 0.74 x 0.4 mm DSBGA package
2. VDDUSB0P9 noise/ripple should be < 3% (peak-to-peak).
 3. On system power-up, VDDUSB33 and VDDUSB0P9 should be in the OFF state.
 4. For power-sequencing considerations, see the applicable datasheet.

Note that for the Apollo510 Lite and Apollo330 Plus SoCs, an internal USB LDO output on VDD0P9 can be used to power VDDUSB0P9 if desired, precluding the need for a 0.9 V regulator.

9.3.3 ESD Protection and Common-mode Filtering

ESD protection on the USB data lines, USB0PP and USB0PN, is required. An integrated CMF and TVS solution, such as the Nexperia PCMF1USB3B/C or Panasonic EXC-14CS900H, is recommended.

If the design achieves EMC compliance without CMF on the USB data lines, then a TVS-only solution, such as the TI ESD122DMXR, may be used.

9.3.4 USB VBUS Detection

The Apollo4 family has no 5 V tolerant pins. Therefore, it relies on the external circuit for getting VBUS power OK (VBUS connected) status. The recommended solution is to connect the PMIC/charger VBUS_OK output to an Apollo4 or Apollo510 GPIO configured as an interrupt.

9.3.5 VDDUSB33 Current Leakage

In the case that VDDUSB33 may be powered while VDDUSB0P9 is powered down, up to 34 mA may be consumed by the USB PHY. This situation should be avoided as it could lead to unnecessary current draw. However, if this scenario is unavoidable due to system design constraints, a 2 M Ω pull-down resistor can be added to both the D+ and D- lines to help mitigate the issue.

This will bring the 3.3 V leakage current below 1 μ A when the 0.9 V rail is powered off, minimizing potential power consumption. This issue exists on the Apollo4 family, Apollo510 family and the Apollo330 Plus Series SoCs. Please refer to Apollo4 Plus erratum ERR056, or Apollo510 family and Apollo330 Plus SoC erratum ERR046, for more details about "High Leakage current in USB PHY".

10. MIPI DSI PHY Guidelines

10.1 Overview

These design guidelines describe connecting to and powering the MIPI Display Serial Interface (DSI) PHY.

10.2 Scope

These guidelines apply to the Apollo4 family and the Apollo510 family SoCs only.

10.3 Guidelines for Apollo4 and Apollo510 SoC Families

10.3.1 Unused

If the MIPI DSI interface is not used, the DSI data and clock pads, MIPI_D0P, MIPI_D0N, MIPI_CLKP and MIPI_CLKN, must be left floating. The MIPI supply pads, VDD18 and VSS18, should be tied to ground.

10.3.2 Power Tree

The recommended power tree for the DSI PHY is as follows:

1. VDD18 is powered by an LDO with output discharge and ON/OFF control over I²C or GPIO. Noise/ripple should be kept to $\pm 2\%$ (72 mV_{pk-pk}), frequency range 10 MHz – 3 GHz.
2. On system power-up, VDD18 should be disabled.

NOTE: On Apollo4 and Apollo4 Blue, powering VDD18 without powering the DSI TX/D-PHY internal power rails results in uncontrolled current leakage to VDD18 and may lead to long-term reliability issues. This has been resolved for Apollo4 Plus devices. Consult the *Apollo4 SoC Datasheet* for proper power-up sequence to avoid this issue.

11. MRAM Guidelines

11.1 Overview

This design guideline provides considerations for preventing MRAM corruption/damage.

11.2 Scope

These guidelines apply to the Apollo4 and Apollo510 SoC families and Apollo330 Plus SoC.

11.3 Guidelines for Apollo4 and Apollo510 Families and Apollo330 Plus Series SoCs

The Apollo4 and Apollo510 SoC families, as well as the Apollo330 Plus Series SoCs contain non-volatile Magneto-resistive Random Access Memory (MRAM). MRAM is susceptible to strong external magnetic fields and requires proper handling in commercial and industrial environments. For design guidelines and system considerations for the Apollo4 family SoCs, reference the Apollo4 MRAM Design Guidelines Application Note A-SOCAP4-ANNA01EN. For Apollo510 guidelines, please contact your Amiq sales representative for applicable documentation.

These SoC architectures have been updated to harden the device against MRAM corruption. This includes holding trims, security configurations and key assets in dedicated anti-fuse-based OTP memory, moving the Secure BootROM to ROM, and adding an MRAM Recovery feature as part of the Secure Boot flow. Please reference the Apollo510 MRAM Recovery Guide and the examples provided in the AmiqSuite SDK for more details.

12. AUDADC Guidelines

12.1 Overview

This design guideline gives recommendations for using and powering the Audio Analog-to-Digital Converter (AUDADC).

12.2 Scope

These guidelines apply to the Apollo4 family and the Apollo510 SoC family excluding the Apollo510 Lite Series SoCs.

12.3 Guidelines for Apollo4 and Apollo510 SoC Families

The Apollo4 and Apollo510 SoC families support a low power analog audio interface, referred to as the AUDADC, for interfacing to analog micro-electro-mechanical systems (MEMS) microphones or line inputs. Apollo4 devices can accept up to two fully differential or pseudo-differential inputs, or four single-ended inputs. Apollo510 devices can accept one fully differential or pseudo-differential input, or two single-ended inputs.

AC-coupling capacitors are used to block the common-mode voltage (VCM) from the Apollo4 and Apollo510 AUDADC PGA input network from the VCM of the chosen ADC input source. These AC-coupling capacitors can be sized between 100 nF to 1 μ F and, together with the input impedance, form a high-pass filter for the input signals.

For best signal-to-noise ratio performance, it is recommended to use an analog microphone (AMIC) with a fully differential signal output. If the AMIC does not provide a fully differential signal, then pseudo-differential signaling must be used. In pseudo-differential mode, the LPADC_DxP pin should be connected to the AMIC output through the selected AC-coupling capacitor, while the LPADC_DxN pin should be connected to ground through a capacitor of the same value. These AC-coupling capacitors can be either X5R or X7R, however X7R is recommended for better performance across temperature.

12.3.1 Microphone Bias

No pull-ups or pull-downs are needed on the microphone (mic) bias lines. MICBIAS can source up to 200 μA at 1.5 V. It should have a 2.2 μF decoupling capacitor.

MICBIAS provides a user-programmable 0.9 V to 1.5 V supply for analog Mems microphones. Microphones that need 1.62 V or greater (up to 1.98 V) can be supplied directly using VDDAUDA. MICBIAS bypass mode is active when the MCUCTRL_AUDIO1_MICBIASVOLTGETRIM[5:0] field is set to 0x3F. This sets MICBIAS as a bypass that outputs VDDAUDA voltage, which allows the MICBIAS circuit to act as a load-switch for analog microphones requiring voltage greater than 1.5 V.

12.3.2 Anti-Aliasing

This section discusses how to tune the corner frequency of the Apollo4 and Apollo510 family AUDADC's anti-aliasing filter using external passive components.

An alias occurs when a signal above half the sample rate is allowed into, or created within, a digital system. An anti-aliasing filter is responsible for limiting the frequency range of the analog input signals before getting converted, so the maximum frequency coming into the system is less than half the sampling rate (Nyquist limit).

The higher the Nyquist frequency, the less risk of distortion. The higher the sampling frequency/oversampling, the less likely it is to capture distortion since you are moving the lower image further away from the wanted audio. The level represents the amplitude of the signal.

Figure 12-1: Frequency of the Apollo4 Family AUDADC's Anti-Aliasing Filter

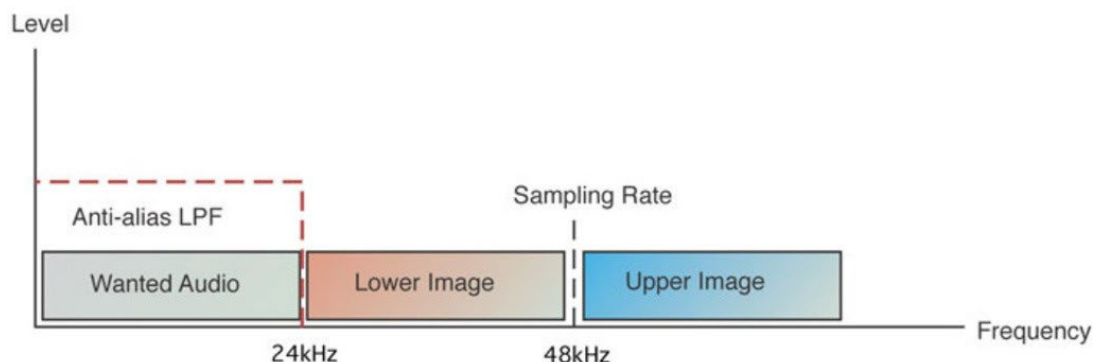
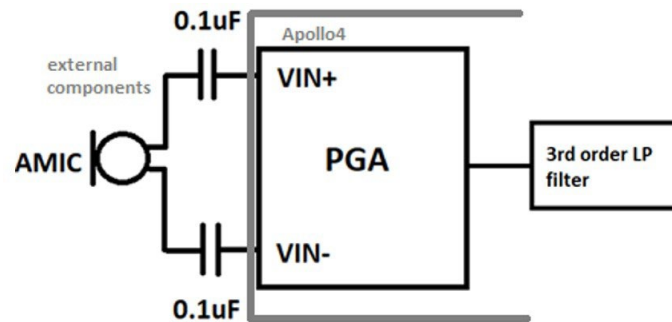

Figure 12-2 is a representation of the AUDADC input circuitry which includes an analog microphone (AMIC), AC coupling capacitors, a programmable gain amplifier (PGA) and the internal anti-aliasing filter.

Figure 12-2: Apollo4 AUDADC Input Circuitry without External Anti-Aliasing Filter Components



In a fully differential topology, the PGA input impedance can be assumed to have the following values.

- If gain ≥ 12 dB, then impedance = 2 M Ω .
- If gain is between 0 dB and 12 dB, the impedance is between 0.49 M Ω and 1.13 M Ω .

The cut off frequency for the third Order RC low pass filter after the PGA is set to 80 kHz.

This is important because, in an audio application, the minimum impedance usually determines how large the AC coupling capacitors between the AMIC and the PGA need to be to get the right high-pass filter corner. The larger the input resistance, the smaller the capacitors need to be for a given corner frequency.

The worst case of the input impedance can be used as a starting point to select the proper resistor values that are at least 5x smaller than the input impedance of the PGA. The smaller value compared to the PGA is to limit the effect of the cut off frequency of the filter.

Figure 11-3 shows a schematic of MIC1 with a first order low pass filter and MIC2 with a second order low pass filter.

Figure 12-3: AUDADC with External Anti-Aliasing Filters

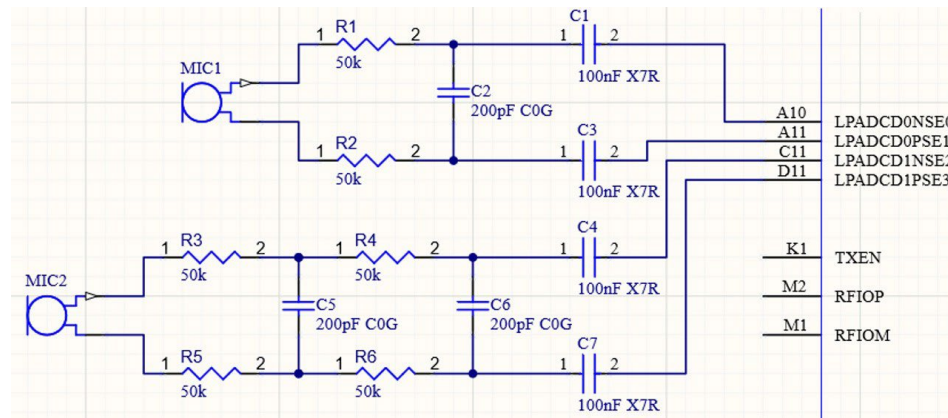

12.3.3 First and Second Order RC Filter Option

Table 12-1: Frequency Cut off (Fc) Equation

Order	Frequency Cut-off Equation
First order roll-off (20 dB per decade after Fc)	$F_c = \frac{1}{2\pi RC}$
Second order roll-off (40 dB per decade after Fc)	$F_c = \frac{1}{2\pi\sqrt{(R_1 R_2 C_1 C_2)}}$ <p>If R1 = R2 and C1 = C2 then:</p> $F_c = \frac{1}{2\pi RC}$

Table 12-2: First and Second Order (with Same R and C) Values for a Determined Fc

C	R	Fc
80 pF	104.5 kΩ	19.04 kHz
100 pF	104.5 kΩ	15.23 kHz
200 pF	104.5 kΩ	7.62 kHz

12.3.4 Simulation Values with LTspice

Circuit simulated: In this drawing, the 4.5 k Ω resistor represents the MIC impedance and the 1 M Ω resistor represents the input impedance of the PGA.

Figure 12-4: Simulated Circuit

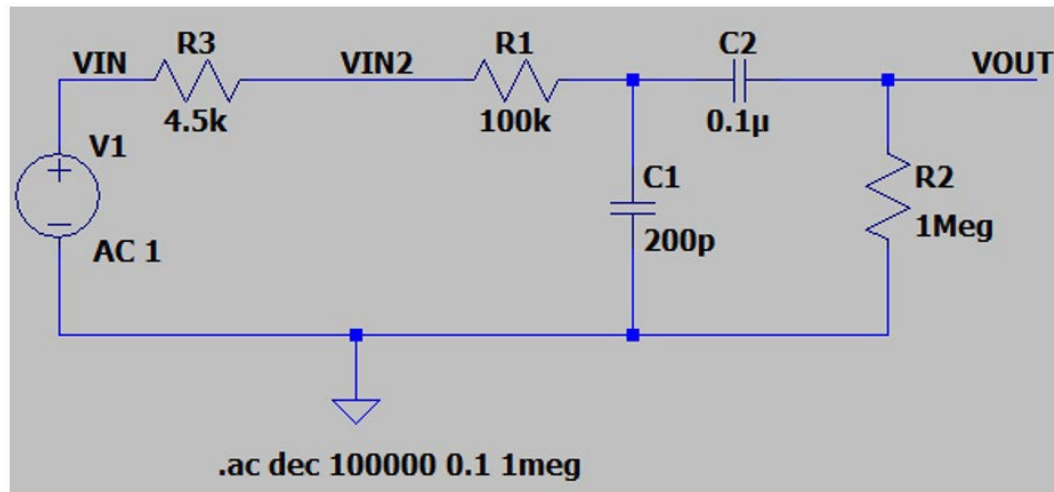
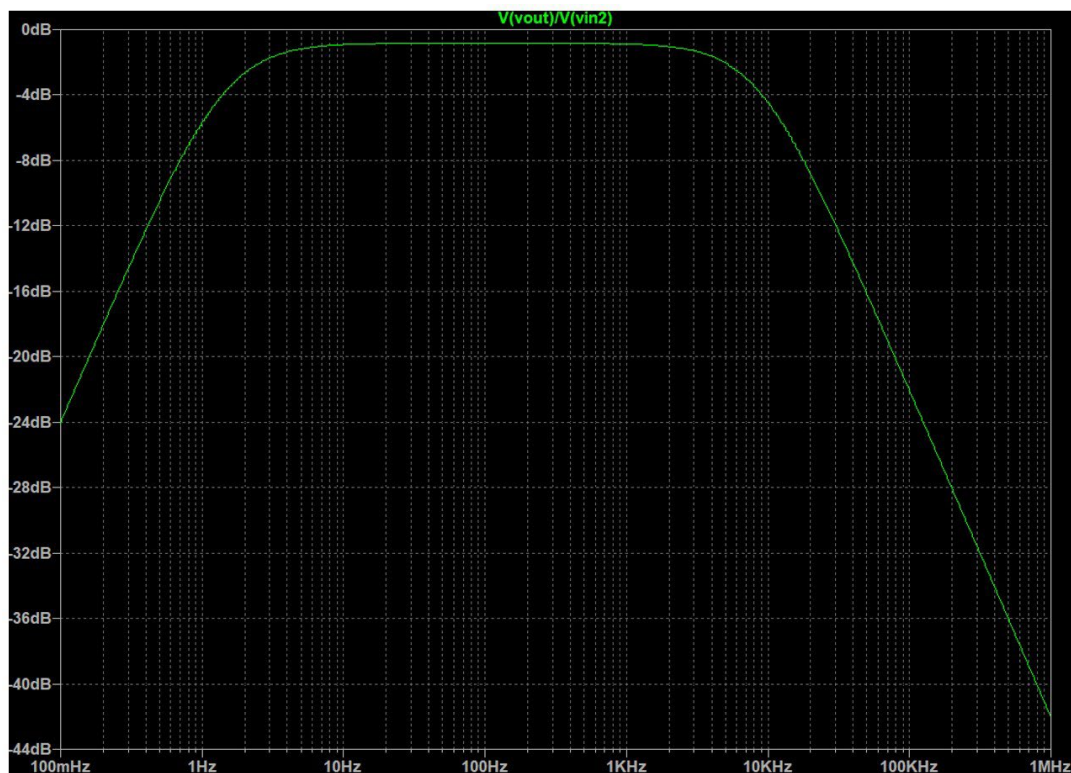

Figure 12-5: Circuit Simulated Results



Component Selection: For audio applications, Ambiq recommends the use of C0G capacitors for their superior performance across temperature, voltage and aging. Be sure to select caps with minimal series ESR and tight tolerances.

13.No-Bluetooth Low Energy Guidelines

13.1 Overview

These design guidelines describe circuit modifications and simplifications when not using Bluetooth Low Energy.

13.2 Scope

These guidelines apply to the Apollo3 SoC Family only.

13.3 Guidelines

The following guidelines should be followed to configure the Apollo3 SoC family when not using Bluetooth Low Energy.

13.3.1 Apollo3 SoC Family

Refer to the Apollo3 Blue or Apollo3 Blue Plus EVB schematic for the full schematic and for components, supplies and circuits referenced below. Note that the BLE inductor remains populated to support operation of turboSPOT® mode in this configuration. If turboSPOT mode is not a requirement, see *Section 13 Apollo3 Family Inductor-less Operation Guidelines* for details on additional hardware configuration changes.

- The DVDD rail is not supplied and the DVDD pin is not connected. Its bypass capacitance is not needed.
- No need for a special VCC supply. Tie the VCC pin to the other supplies (VDDP, VDDH, VDDA and VDDB)
- The 32 MHz crystal circuit is not needed. X032MP and X032MM may be left floating
- The antenna circuit is not needed. RFIOP may be left floating, RFIOM should be connected to PCB ground
- All VSS pins, including VSSB, are tied to PCB GND.

14. Inductor-less Operation Guidelines

14.1 Overview

These design guidelines describe when and how the SIMO Buck and BLE Buck inductors may be omitted.

14.2 Scope

This applies for all Apollo3 SoC Family only.

14.3 Guidelines

The following guidelines should be taken into consideration when designing the system hardware for applications not using SIMO Buck and BLE Buck inductors.

14.3.1 Apollo3 SoC Family

For space-constrained applications, the user may decide not to include the SIMO Buck and BLE Buck inductors in the design. Note that the BLE Buck circuit, which includes the BLE inductor, also provides power for high-speed TurboSPOT mode. If TurboSPOT is not required, the BLE Buck inductor may be removed. BLE production trims are calibrated with the BLE Buck turned on. For Bluetooth Low Energy enabled designs without the BLE Buck inductor, it is required to keep the system operating voltage at 1.8 V. Also, removing the SIMO Buck inductor disables SIMO Buck mode, in which case only LDO mode is available.

14.3.2 SIMO Buck

SIMOBUCK_SW and SIMOBUCK_SWSEL may be left floating. In this configuration, the OTP_CUSTOMER_TRIM setting must have the SIMO_BUCK disabled by setting the PWRCTRL_MISC_SIMOBUCKEN bit to '0'. In this configuration, the SIMO Buck circuit remains powered down. Consult the Apollo3 SoC Datasheet.

14.3.3 BLE Buck

The BLE inductor is replaced with a 0 Ω resistor, creating a short between VDDBH_SW and VDDBH. The 4.7 μF bypass capacitor on VDDBH should remain for local bypass capacitance. If Bluetooth Low Energy operation is intended,

then the 1 μF VDCDCRF capacitor should remain as well. Otherwise, for non-Bluetooth Low Energy operation, VDCDCRF's bypass capacitor may be removed.

Figure 14-1: BLE Inductor

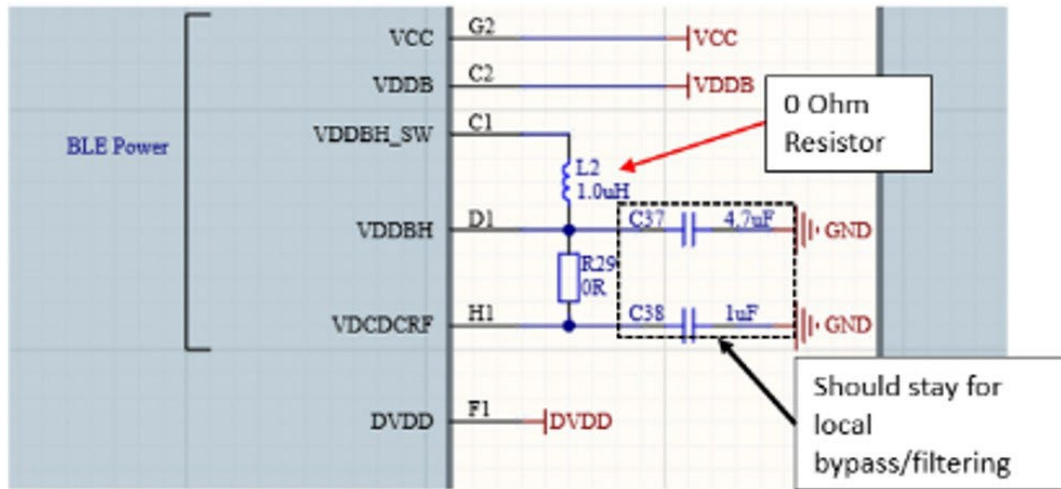

15. Appendix - Review Checklists

This appendix includes two review checklist forms:

- Schematic Review Checklist
- Layout Review Checklist

15.1 Schematic Review Checklist

15.1.1 Overview

This sub-section of the design review appendix provides a checklist when conducting a schematic review of an Apollo SoC design.

15.1.2 Scope

This checklist applies to Apollo3, Apollo4, Apollo510/510B/510 Lite families, as well as the Apollo330 Plus Series SoCs. It is noted if a guideline does not apply to all SoC families.

15.1.3 Guidelines for All SoC Families

Table 15-1: Schematic Review Checklist

Item	Schematic Review Checklist	
1	Confirm the Ambiq SoC symbol against the package appropriate pin numbers provided in the datasheet to ensure correct mapping of power, signal and ground pads.	<input type="checkbox"/>
2	<p>Verify all intended GPIO and peripheral connections against the Apollo SoC family pin map in the datasheet. Alternatively, the Ambiq-provided pin mapping spreadsheets available in the Content Portal can assist with this:</p> <ul style="list-style-type: none"> ▪ Apollo3 family pin mapping <p>See the <i>NCE Encoding Table</i> in the Apollo3 Blue or Apollo3 Blue Plus Datasheets for chip select mapping considerations.</p> <ul style="list-style-type: none"> ▪ Apollo4 family pin mapping ▪ Apollo510 family pin mapping ▪ Apollo510B SoC pin mapping ▪ Apollo510 Lite SoC pin mapping ▪ Apollo330 Plus SoC pin mapping 	<input type="checkbox"/>
3	Check the reset pin. External 1nF capacitor recommended to filter external noise/glitches. Consider including pads for an external pull-up resistor. If an external IC is connected to control nRST, it must be open drain.	<input type="checkbox"/>
4	<p>Check SWDCK and SWDIO, which should be connected to a debug header.</p> <ul style="list-style-type: none"> ▪ SWDCK needs a 10 kΩ pull-down resistor. ▪ SWDIO needs a 10 kΩ pull-up resistor. 	<input type="checkbox"/>
5	Check SWO, which is recommended to be routed to a header or test point.	<input type="checkbox"/>
6	Check all decoupling and bypass capacitor values to ensure they're meeting recommended values. Confirm the SIMO Buck and BLE Buck (if applicable) inductors meet the recommended specifications.	<input type="checkbox"/>
7	Confirm 32 kHz XTAL and 32 MHz XTAL (if applicable) specifications meet datasheet recommendations. If an external high-speed oscillator is used, confirm it meets the requirements.	<input type="checkbox"/>

8	<p>Ensure the design follows the SoC errata guidelines. All errata should be reviewed, with particular attention paid to the following:</p> <ul style="list-style-type: none">▪ Apollo3: ERR029▪ Apollo3 Plus: ERR022, ERR023, ERR025, ERR029▪ Apollo4: ERR008, ERR014, ERR039, ERR046, ERR056, ERR066, ERR070, ERR087, ERR096, ERR108.▪ Apollo4 Plus: ERR008, ERR039, ERR046, ERR056, ERR066, ERR087, ERR096, ERR097.	<input type="checkbox"/>
9	<p>Apollo4 and Apollo510 families and Apollo330 Plus SoC only: Although it is recommended to power-up VDDUSB33 and VDDUSB0P9 together only when USB is to be used, it is possible to keep VDDUSB33 powered at all times. In that case it is required that a 2 MΩ pull-down resistor be included on each of the USB data lines to prevent leakage current.</p> <ul style="list-style-type: none">▪ Apollo4: ERR056▪ Apollo510: ERR046▪ Apollo330 Plus: ERR046	<input type="checkbox"/>

15.2 Layout Review Checklist

15.2.1 Overview

These design guidelines list layout considerations in the form of a checklist for an Apollo SoC layout design.

15.2.2 Scope

This checklist applies to Apollo3, Apollo4, Apollo510/510B/510 Lite families, as well as the Apollo330 Plus Series SoCs. It is noted when a guideline does not apply to all three SoC families.

15.2.3 Guidelines for All SoC Families

This section provides guidance for the layout of components within modules supported by the Apollo SoCs.

Table 15-2: Layout Review Checklist

Layout Review Checklist		
Item	Power	
A1	Decoupling capacitors, such as those for VDDP, VDDA and VDDH, should be as close as possible to their respective pins.	<input type="checkbox"/>
A2	For power rails that connect to inner balls of the SoC, the decoupling capacitor should ideally be placed on the opposite side of the SoC, directly under the pin, with a via to connect them. If a via must be used to connect to a capacitor on the same surface as the SoC, the trace should be kept as short as possible.	<input type="checkbox"/>
A3	For the Buck inductors (SIMO Buck and BLE Buck), it is recommended to have solid ground underneath the traces and inductors.	<input type="checkbox"/>
A4	SIMO and BLE Buck traces should be as thick and as short as possible. If it is not possible to minimize both inductor traces, the switch node (e.g., SIMOBUCK_SW) should be prioritized for the shortest trace length.	<input type="checkbox"/>
A5	If using Bluetooth Low Energy and/or Audio, VDDAUDA should be routed in such a way to minimize its exposure to high frequency and noisy signals, such as MSPI clock signals or Buck converter outputs. It is recommended to have it shielded with ground.	<input type="checkbox"/>
A6	Power connections should be routed with planes. If not possible, use traces that are as thick as possible within the design constraints.	<input type="checkbox"/>
Item	Oscillators	
B1	Oscillator traces and components should be shielded as much as possible with ground.	<input type="checkbox"/>
B2	Maintain a solid ground plane on the layer adjacent to the oscillator circuitry, avoiding routing other signals directly underneath the crystal and capacitors.	<input type="checkbox"/>

Item	MSPI	
C1	MSPI signals should be impedance matched to $50 \Omega \pm 20\%$, using a solid reference plane.	<input type="checkbox"/>
C2	MSPI signals should not be routed over any discontinuities in the reference plane.	<input type="checkbox"/>
C3	Ideally, all MSPI signals in a group should be routed on the same signal layer.	<input type="checkbox"/>
C4	MSPI Data signals should be trace-length matched to within ± 500 mils of the Clock signal. For Apollo510 MSPI0 and MSPI3, and Apollo510 Lite/Apollo330 Plus MSPI0 and MSPI2 data signals should be matched within ± 200 mils of the clock signal.	<input type="checkbox"/>
C5	Minimize the use of vias as much as possible.	<input type="checkbox"/>
C6	For Apollo3 Blue Plus, the capacitance loading on any MSPI signal (clock and data lines) is limited to no higher than 30 pF. For the Apollo4 Family and Apollo510 MSPI1 and MSPI2, the limit is 20 pF.	<input type="checkbox"/>
C7	For Apollo510 MSPI0 and MSPI3, Apollo510B MSPI0, and Apollo510 Lite/Apollo330 Plus MSPI0 and MSPI2, the total routed length of an MSPI interface should be less than 1 inch.	<input type="checkbox"/>
C8	For Apollo510 MSPI0 and MSPI3, Apollo510B MSPI0, and Apollo510 Lite/Apollo330 Plus MSPI0 and MSPI2, only a single device should be connected when operating at 250 MT/s.	<input type="checkbox"/>
Item	IOM SPI	
D1	IOM SPI can support clock rates up to 48 MHz; thus it is recommended to follow the MSPI layout guidelines above.	<input type="checkbox"/>
D2	For Apollo3 Blue Plus, the capacitance loading on any IOM SPI signal (clock, MISO and MOSI) is limited to no higher than 25 pF. The minimum MISO input data setup time is 4 ns.	<input type="checkbox"/>
Item	MIPI	
E1	$50 \Omega \pm 15\%$ single-ended, $100 \Omega \pm 15\%$ differential.	<input type="checkbox"/>
E2	MIPI clock and data trace pairs should be trace-length matched as closely as possible, <50mil.	<input type="checkbox"/>
E3	MIPI maximum length difference within a differential pair, <5mil.	<input type="checkbox"/>
E4	Continuous ground reference spaces with a separation distance of 3x the trace width from other signals	<input type="checkbox"/>
E5	Maintain a solid ground reference for the MIPI traces, avoid routing over any discontinuities in the plane.	<input type="checkbox"/>
E6	Minimize the use of vias in high-speed differential pairs to avoid impedance discontinuities.	<input type="checkbox"/>

Item	USB	
F1	The USB signals should be impedance matched to $50\ \Omega \pm 15\%$ single-ended, $90\ \Omega \pm 15\%$ differential.	<input type="checkbox"/>
F2	The USB trace pair should be trace-length matched as closely as possible and should not exceed 50 mils in trace length difference.	<input type="checkbox"/>
F3	Maintain a solid ground reference for the USB traces, avoid routing over any discontinuities in the plane.	<input type="checkbox"/>
F4	Minimize via use as much as possible.	<input type="checkbox"/>
Item	Radio	
G1	The RFIOP trace connecting to the matching network and antenna should be impedance controlled to $50\ \Omega$.	<input type="checkbox"/>
G2	Maintain a solid ground plane beneath and next to the matching components and traces leading to the antenna.	<input type="checkbox"/>
G3	Follow RF guidelines mentioned in this document for the specific SoC (currently only Apollo510B).	<input type="checkbox"/>
Item	eMMC	
H1	eMMC signals should be impedance matched to $50\ \Omega \pm 15\%$.	<input type="checkbox"/>
H2	eMMC data and CMD signals should be trace-length matched to within ± 500 mils of the clock signal.	<input type="checkbox"/>
H3	eMMC signals should be referenced to a solid plane (VDD or GND).	<input type="checkbox"/>
H4	eMMC signals should not be routed over any discontinuities in the reference plane.	<input type="checkbox"/>
H5	Apollo510 only: The capacitive loading on an eMMC signal should be limited to 13pF or less.	<input type="checkbox"/>
Item	AUDADC	
I1	AUDADC positive and negative signals should be routed differentially, with ground surrounding and shielding the traces on the adjacent layer.	<input type="checkbox"/>
I2	Match the routing of the AUDADC channels as closely as possible.	<input type="checkbox"/>
I3	Minimize impedance by increasing AUDADC trace width.	<input type="checkbox"/>

Item	ETM	
J1	Place the ETM connector as close as possible to the Apollo SoC.	<input type="checkbox"/>
J2	Avoid sharing ETM trace pins with other GPIO functions.	<input type="checkbox"/>
J3	ETM signals should be impedance matched to $50 \Omega \pm 15\%$.	<input type="checkbox"/>
J4	ETM signals should be referenced to a solid plane (VDD or GND).	<input type="checkbox"/>
J5	To minimize overshoot and ringing, it is recommended to place series resistors at the output pins of the Apollo SoC. $27\text{-}33 \Omega$ is a typical range.	<input type="checkbox"/>
J6	ETM data signals should be length-matched within 390 mil of the clock signal to minimize calibration during setup.	<input type="checkbox"/>

Blank Page



©2026 Ambiq Micro, Inc. All rights reserved.

6500 River Place Boulevard, Building 7, Suite 200, Austin, TX 78730

www.ambiq.com

sales@ambiq.com

+1 (512) 879-2850

A-SOCAPG-UGGA02EN v4.0

May 2026