

1/24/2022

1) Initial Release

P01: Revision History

THIS DOCUMENT CONTAINS INFORMATION PROPRIETARY TO AMBIQ AND SHALL NOT BE USED, REPRODUCED, OR DISCLOSED TO OTHERS, IN PART OR WHOLE, WITHOUT EXPRESS WRITTEN PERMISSION FROM AMBIQ.			AMBIQ 5500 River Place Blvd. Building 7, Suite 200 Austin, TX 78730	
	Title <b>AMA4BPEVB</b>			
Size <b>C</b>	Drawn by: C Crosby	01/31/22	Document Number	Rev
	Check by:		<b>AMSCH-0088</b>	<b>1</b>
	Apv'd by:			
www.ambiq.com		Date: Wednesday, February 16, 2022		Sheet 1 of 10

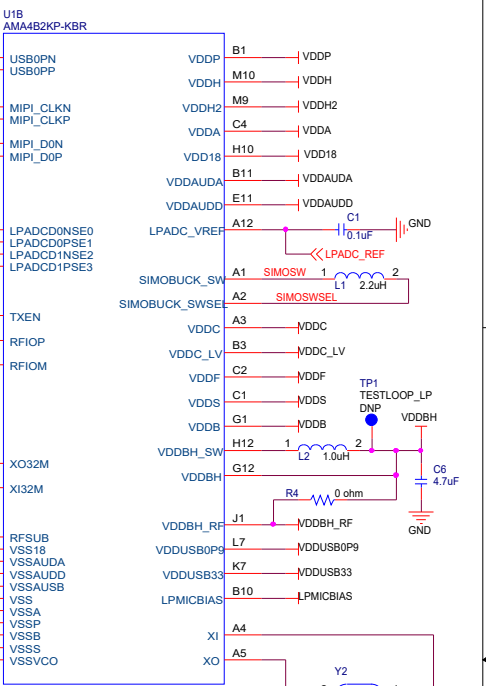
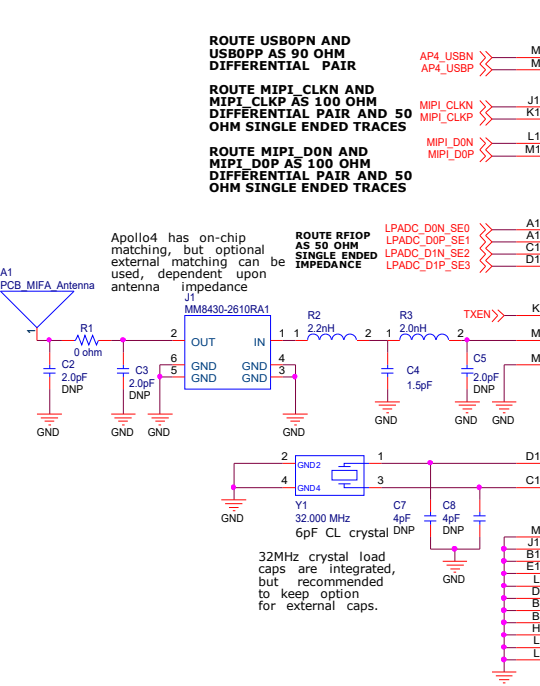
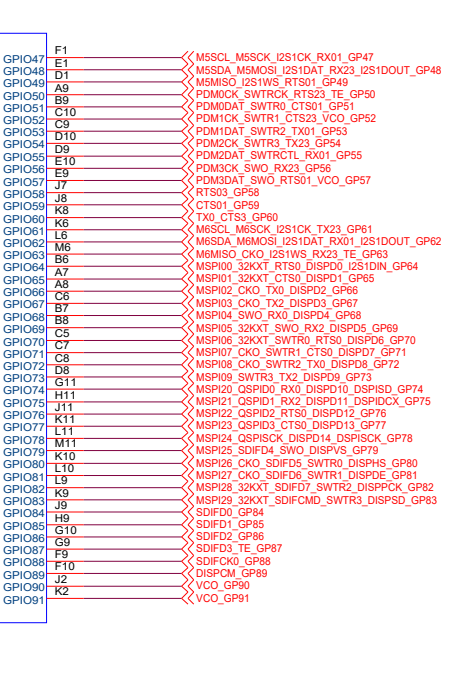
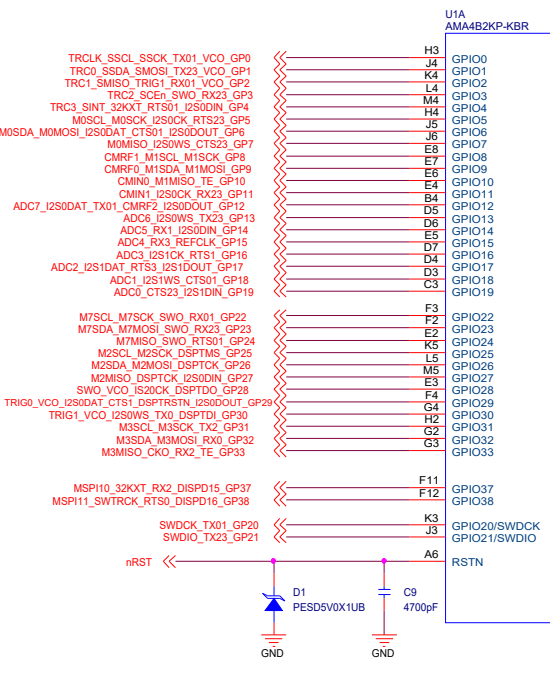

P02: Apollo 4 Blue Plus MCU

THIS DOCUMENT CONTAINS INFORMATION PROPRIETARY TO AMBIQ AND SHALL NOT BE USED, REPRODUCED OR DISCLOSED TO OTHERS, IN PART OR WHOLE, WITHOUT EXPRESS WRITTEN PERMISSION FROM AMBIQ.

www.ambiq.com

**ambiq**

AMBIQ  
6500 River Place Blvd.  
Building 7, Suite 200  
Austin, TX 78730

Title		AMA4BPEVB	
Size	Drawn by: C Crosby	01/31/22	Document Number
C	Check by:		AMSCH-0088
	Approved by:		1
Date: Wednesday, February 16, 2022			Sheet 2 of 10

**1.9V REGULATOR** 1.9V Default. Connect SB51 for 1.8V

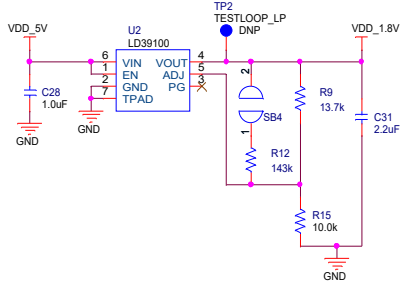

**3.3V REGULATOR**

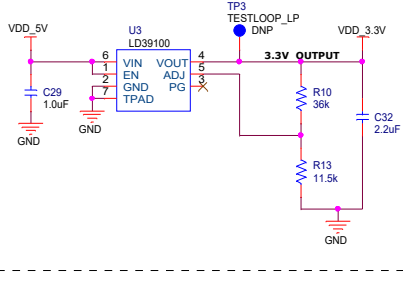

**FALCON 0.9V USB SUPPLY**

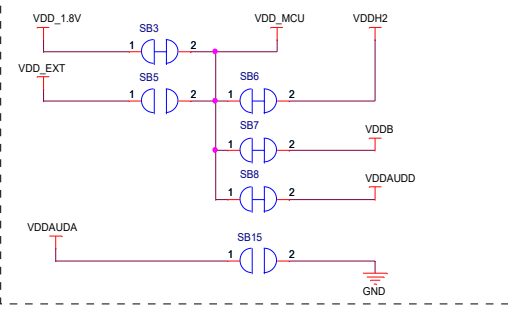
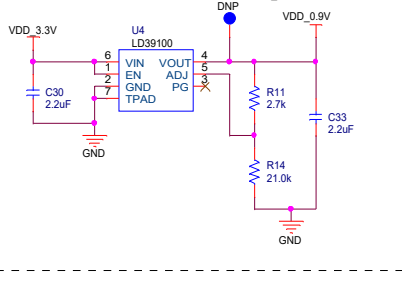

**1.8V LOW NOISE SUPPLY**

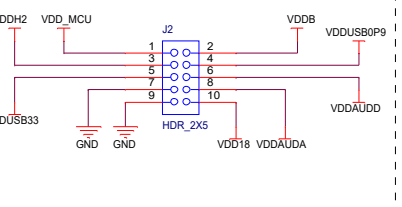
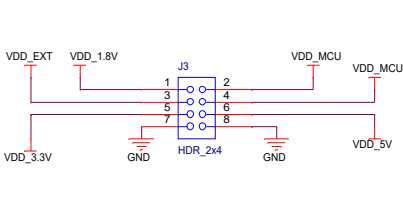
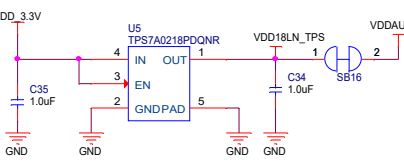

**LED GPIO Solder-Bridges**

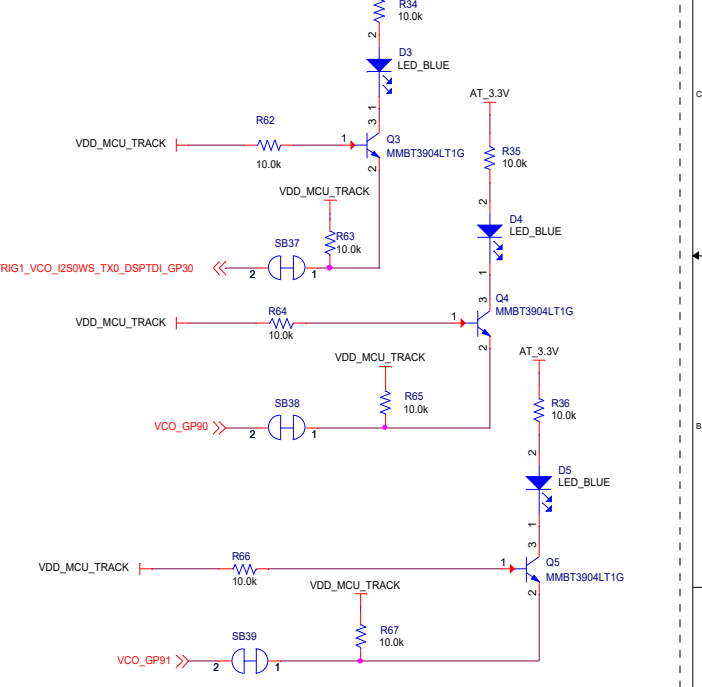

**USB SEQUENCING**

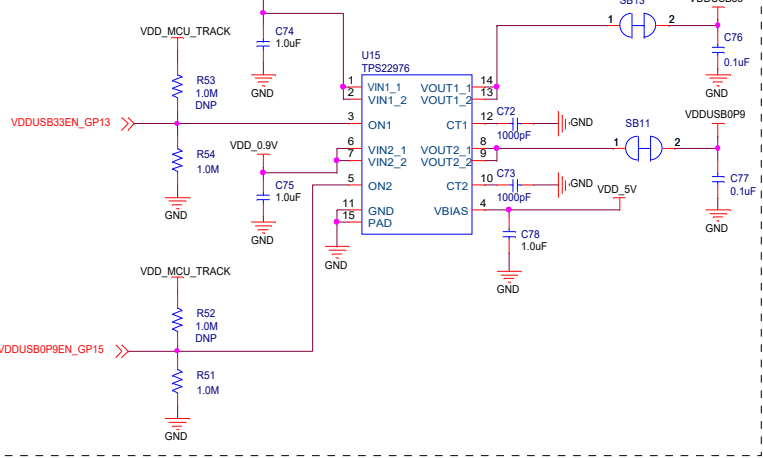

**MIPI SEQUENCING**

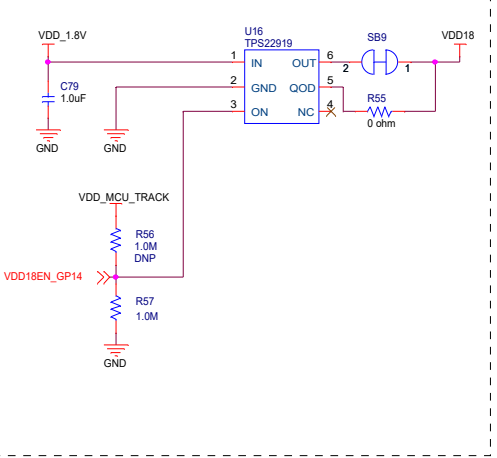

**GND TEST LOOPS**

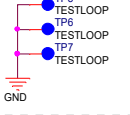

**P03: Power Supplies**

THIS DOCUMENT CONTAINS INFORMATION PROPRIETARY TO AMBiq AND SHALL NOT BE USED, REPRODUCED, OR DISCLOSED TO OTHERS, IN PART OR WHOLE, WITHOUT EXPRESS WRITTEN PERMISSION FROM AMBiq.						AMBiq 6500 River Place Blvd. Building 7, Suite 200 Austin, TX 78730	
Title <b>AMA4BPEVB</b>							
Size <b>C</b>	Drawn by: C Crosby	01/31/22	Document Number	Rev			
	Check by:		<b>AMSCH-0088</b>	1			
	Aprvd by:						
Date: Wednesday, February 16, 2022				Sheet3 of 10			

www.ambiq.com

### AP4 USB Connector

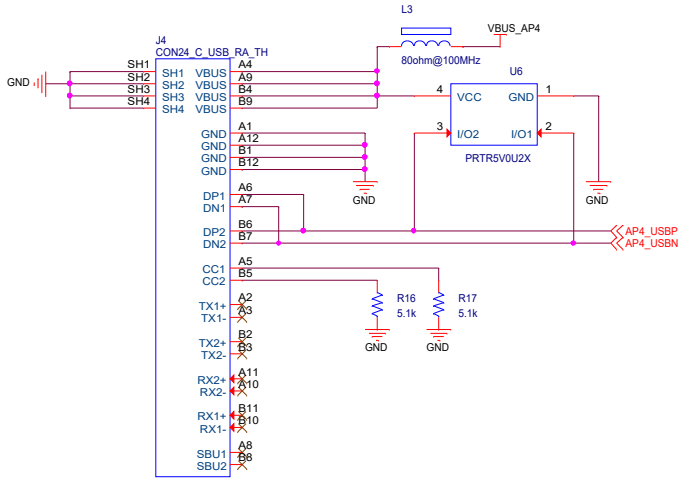

### J-Link USB Connector

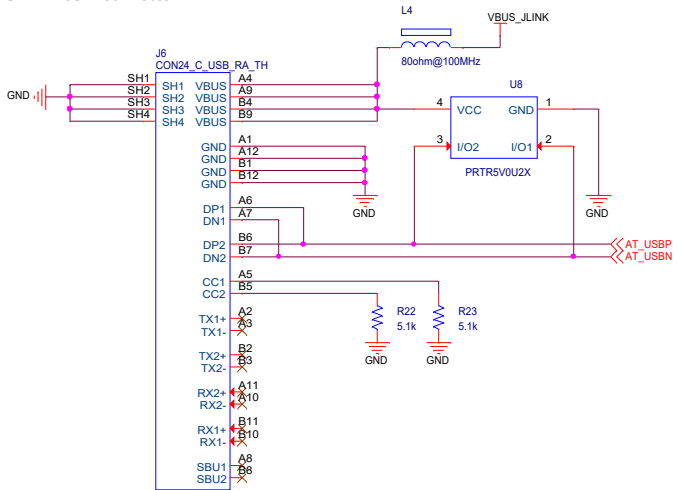

### 5V Source Select & USB Protection Circuit

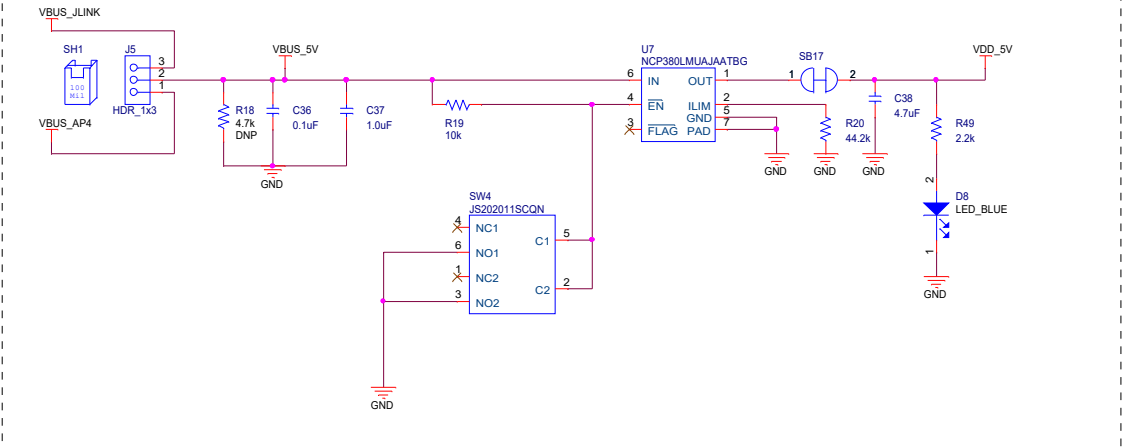

### P04: USB

THIS DOCUMENT CONTAINS INFORMATION PROPRIETARY TO AMBiq AND SHALL NOT BE USED, REPRODUCED, OR DISCLOSED TO OTHERS, IN PART OR WHOLE, WITHOUT EXPRESS WRITTEN PERMISSION FROM AMBiq.

www.ambiq.com



AMBiq  
5500 River Place Blvd.  
Building 7, Suite 200  
Austin, TX 78730

Title			
<b>AMA4BPEVB</b>			
Size	Drawn by: C Crosby	01/31/22	Document Number
<b>C</b>	Check by:		<b>AMSCH-0088</b>
Date: Wednesday, February 16, 2022	Aprvd by:		Rev
			<b>1</b>

### J-Link Onboard Debugger

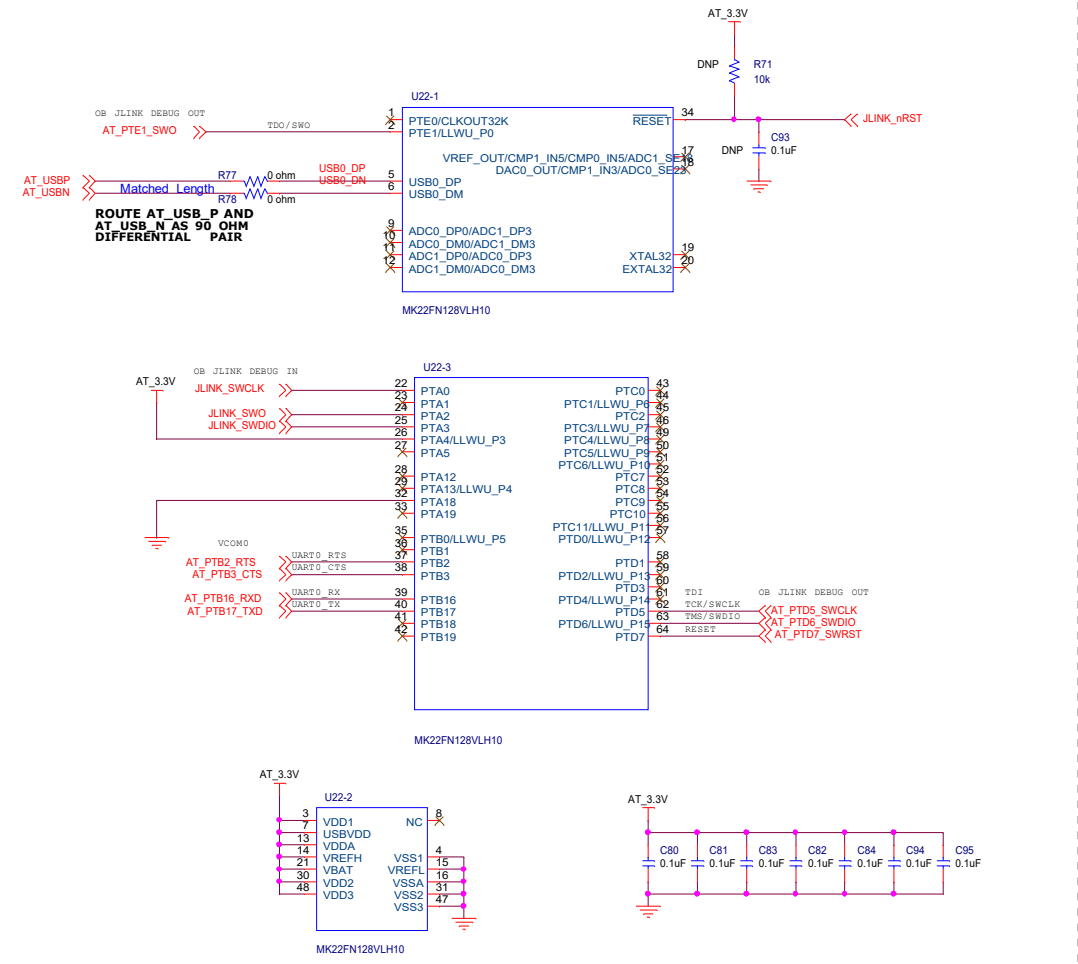

### J-Link Voltage Disconnect Solder-Bridges

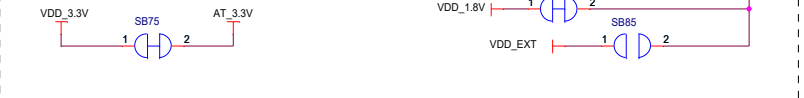

### J-Link SWD Connections and Level Translation

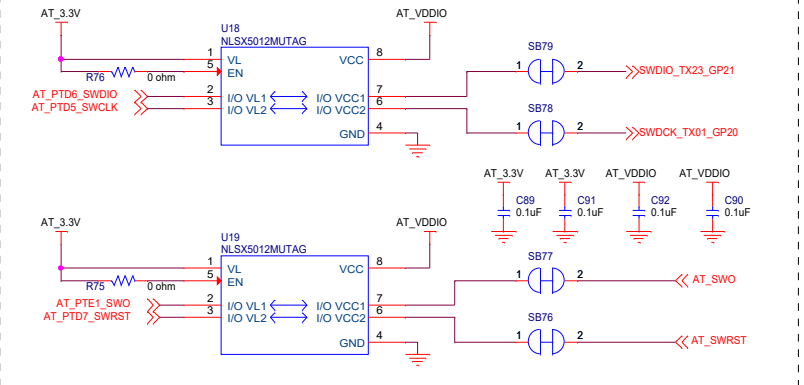

### J-Link To AP4 UART Solder-Bridges and Level Translation

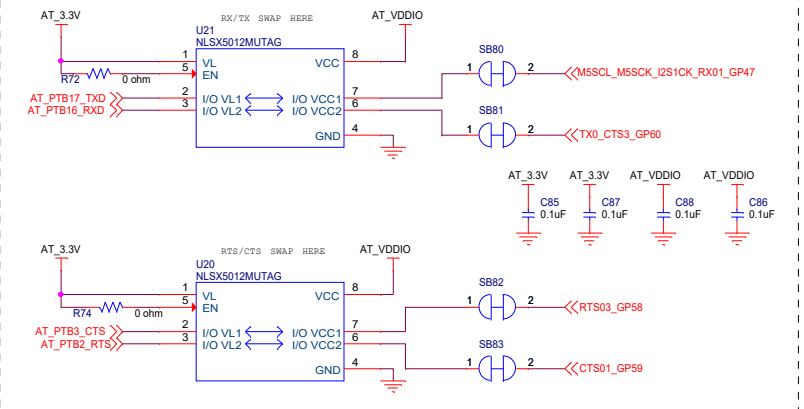

### P05: Debugger

THIS DOCUMENT CONTAINS INFORMATION PROPRIETARY TO AMBiq AND SHALL NOT BE USED, REPRODUCED, OR DISCLOSED TO OTHERS, IN PART OR WHOLE, WITHOUT EXPRESS WRITTEN PERMISSION FROM AMBiq.

**www.ambiq.com**



AMBiq  
 6500 River Place Blvd.  
 Building 7, Suite 200  
 Austin, TX 78730

Title <b>AMA4BPEVB</b>			
Size	Drawn by: C Crosby	01/31/22	Document Number
C	Check by:		<b>AMSCH-0088</b>
Date: Wednesday, February 16, 2022	Apv'd by:		Rev <b>1</b>
			Sheet 5 of 10

### Arduino-Style GPIO Headers

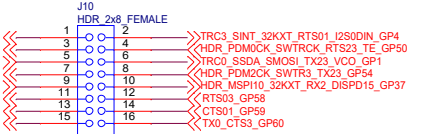
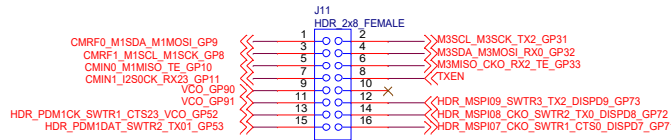
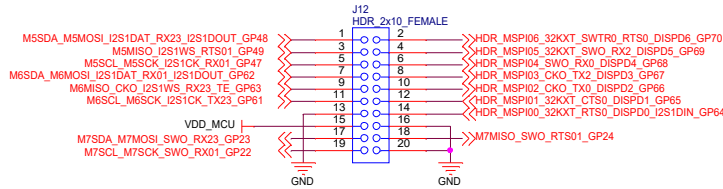
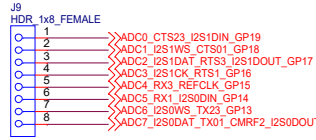
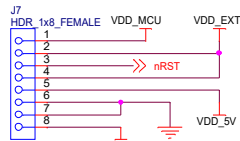

### Display Controller GPIO Solder-Bridges



### USB/MIPI Sequence Control

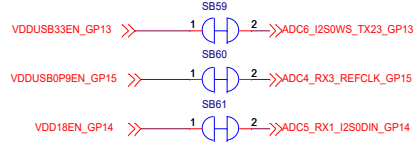

### High-Speed Header

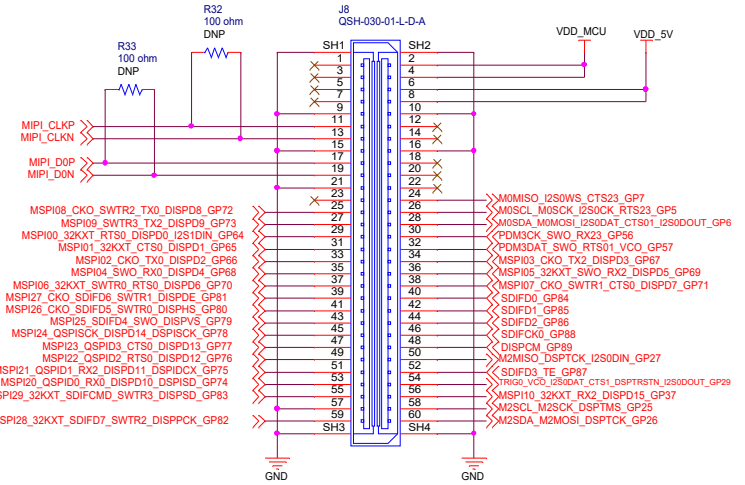

### Debug Signal to GPIO Connector Solder-Bridges

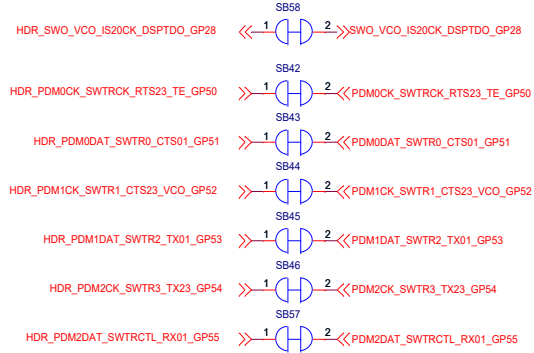

### P06: GPIO Headers

THIS DOCUMENT CONTAINS INFORMATION PROPRIETARY TO AMBiq AND SHALL NOT BE USED, REPRODUCED OR DISCLOSED TO OTHERS, IN PART OR WHOLE, WITHOUT EXPRESS WRITTEN PERMISSION FROM AMBiq.

**AMBiq**  
 6500 River Place Blvd.  
 Building 7, Suite 200  
 Austin, TX 78730

**Title: AMA4BPEVB**

Size	Drawn by: C Crosby	01/31/22	Document Number	Rev
C	Check by:		<b>AMSCH-0088</b>	1
	Apv'd by:			

**www.ambiq.com**

Date: Wednesday, February 16, 2022

Sheet 6 of 10

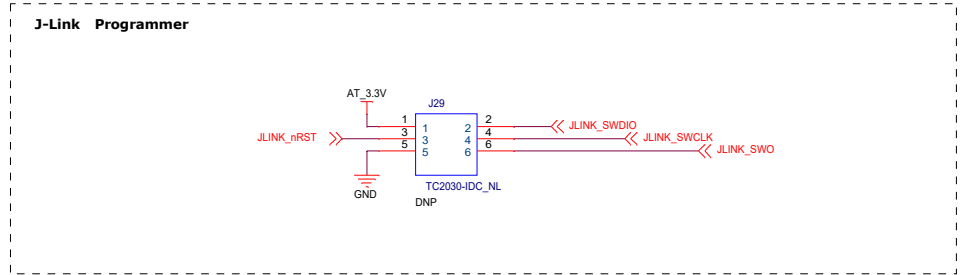
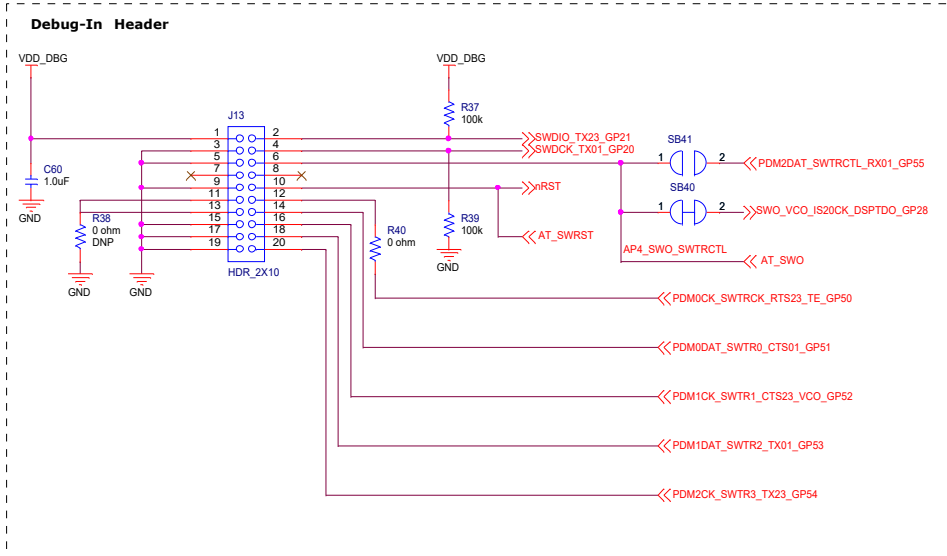

## P07: Debug Headers and Support

THIS DOCUMENT CONTAINS  
INFORMATION PROPRIETARY  
TO AMBiq AND SHALL NOT BE  
USED, REPRODUCED, OR  
DISCLOSED TO OTHERS, IN  
PART OR WHOLE, WITHOUT  
EXPRESS WRITTEN PERMISSION  
FROM AMBiq.



AMBiq  
5500 River Place Blvd.  
Building 7, Suite 200  
Austin, TX 78730

Title			
<b>AMA4BPEVB</b>			
Size	Drawn by: C Crosby	01/31/22	Document Number
<b>C</b>	Check by:		<b>AMSCH-0088</b>
	Apv'd by:		<b>1</b>
Date: Wednesday, February 16, 2022			Sheet 7 of 10

www.ambiq.com

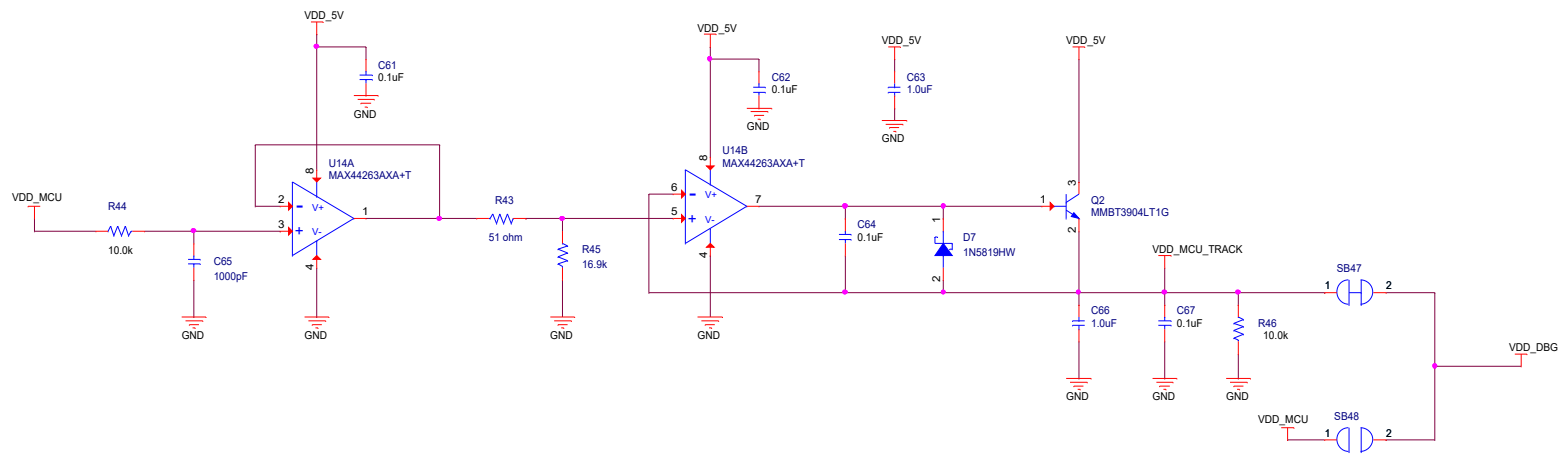

P08: Power Supply Tracker

THIS DOCUMENT CONTAINS  
 INFORMATION PROPRIETARY  
 TO AMBQ AND SHALL NOT BE  
 USED, REPRODUCED, OR  
 DISCLOSED TO OTHERS, IN  
 PART OR WHOLE, WITHOUT  
 EXPRESS WRITTEN PERMISSION  
 FROM AMBQ.



AMBQ  
 6500 River Place Blvd.  
 Building 7, Suite 200  
 Austin, TX 78730

Title			
<b>AMA4BPEVB</b>			
Size	Drawn by: C Crosby	01/31/22	Document Number
<b>C</b>	Check by:		<b>AMSCH-0088</b>
Date: Wednesday, February 16, 2022	Rev	1	
www.ambiq.com		Sheet 8 of 10	



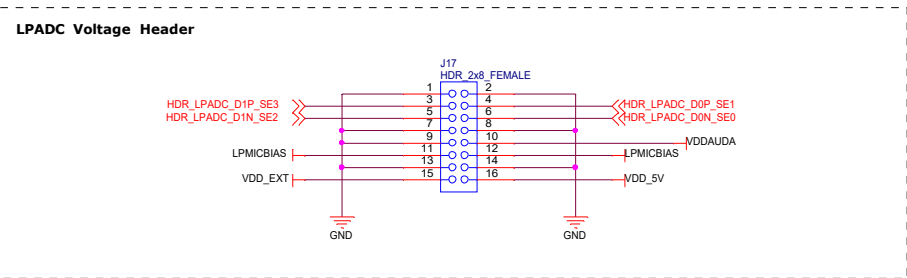
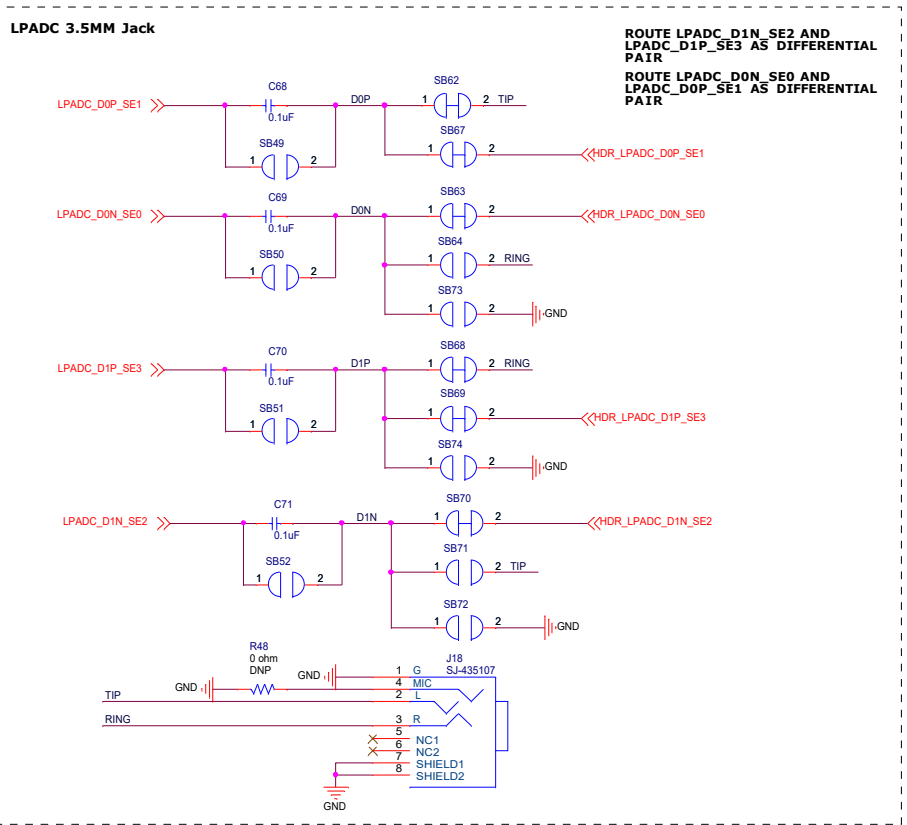

P09: Audio Connections

THIS DOCUMENT CONTAINS INFORMATION PROPRIETARY TO AMBQ AND SHALL NOT BE USED, REPRODUCED, OR DISCLOSED TO OTHERS, IN PART OR WHOLE, WITHOUT EXPRESS WRITTEN PERMISSION FROM AMBQ.

www.ambiq.com

		AMBQ 5500 River Place Blvd. Building 7, Suite 200 Austin, TX 78730	
		<b>Title</b> <b>AMA4BPEVB</b>	
<b>Size</b> <b>C</b>	<b>Drawn by:</b> C Crosby <b>Check by:</b> <b>Apv'd by:</b>	<b>Date:</b> 01/31/22 <b>Document Number:</b> AMSCH-0088	<b>Rev</b> <b>1</b>
<b>Date:</b> Wednesday, February 16, 2022		<b>Sheet</b> 9 <b>of 10</b>	

**J7 Testpoints**

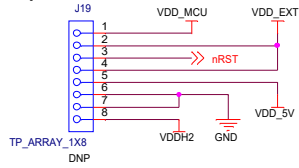

**J9 Testpoints**

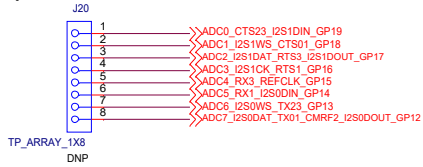

**J12 Testpoints**

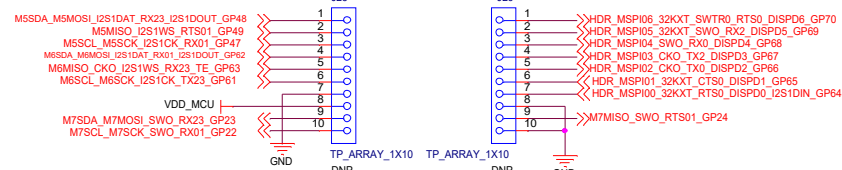

**J11 Testpoints**

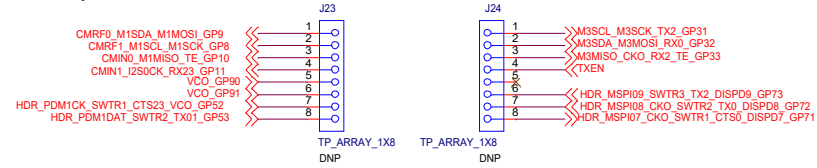

**J10 Testpoints**

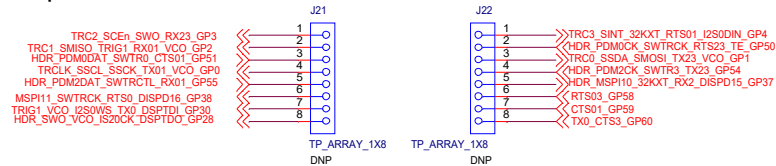

P10: Testpoint Arrays

<p>THIS DOCUMENT CONTAINS INFORMATION PROPRIETARY TO AMBiq AND SHALL NOT BE USED, REPRODUCED, OR DISCLOSED TO OTHERS, IN PART OR WHOLE, WITHOUT EXPRESS WRITTEN PERMISSION FROM AMBiq.</p>				<p>AMBiq 5500 River Place Blvd. Building 7, Suite 200 Austin, TX 78730</p>	
<p>Title: <b>AMA4BPEVB</b></p>					
Size: <b>C</b>	Drawn by: C Crosby	01/31/22	Document Number:	Rev	
	Check by:		<b>AMSCH-0088</b>		1
	Apv'd by:				
<p>www.ambiq.com</p>			<p>Date: Wednesday, February 16, 2022</p>		<p>Sheet 10 of 10</p>