

Connection Diagram

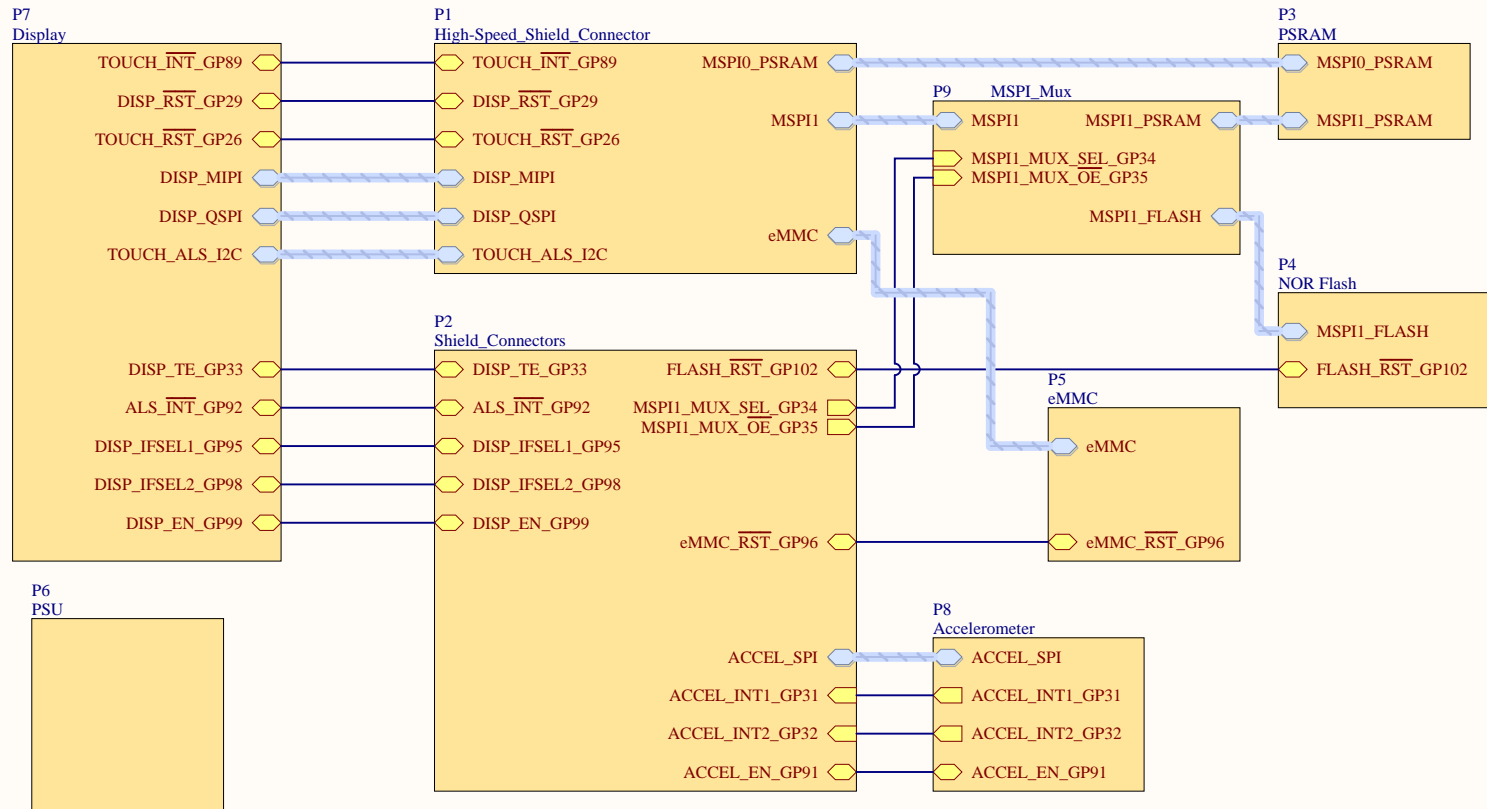

Revision History:
2/2/2022: Initial Release V1



6500 River Place Boulevard
Building 7, Suite 200
Austin, TX 78730
+1 (512) 879-2850

Title
AMAP4PDISP

Size A	Number AMSCH-0087	Revision 1	Sheet 1 of 10
Date 3/10/2022	Drawn By Chad Crosby	3/10/2022	
	Aprvd By Daniel Lanzone	11/8/2022	

This document contains information proprietary to Ambiq and shall not be used, reproduced, or disclosed to others, in part or in whole, without express written permission from Ambiq.

Highspeed Header

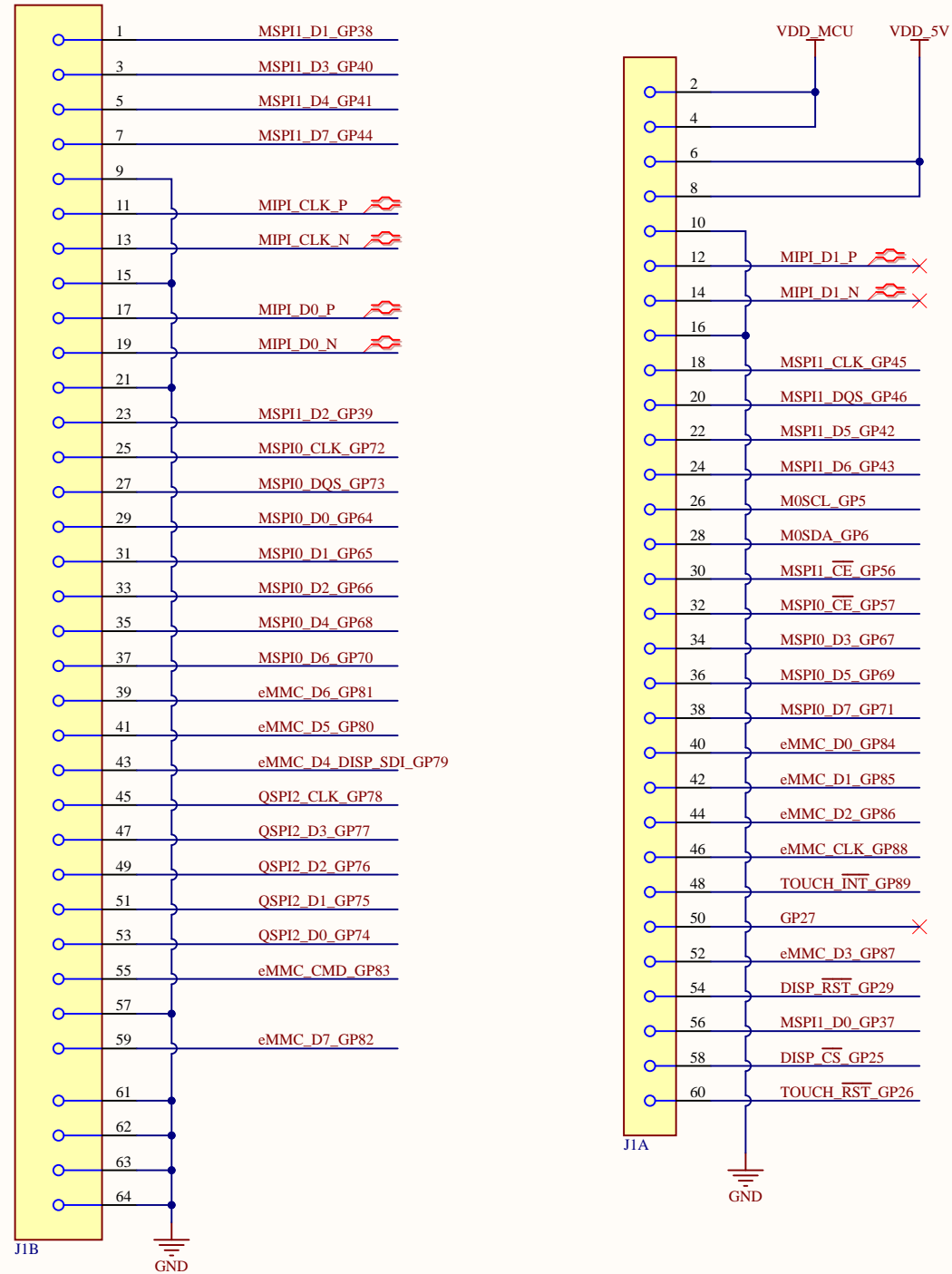

Ground Hooks

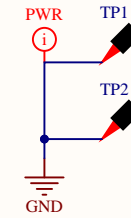

Display Shield Apollo4 Plus Signals

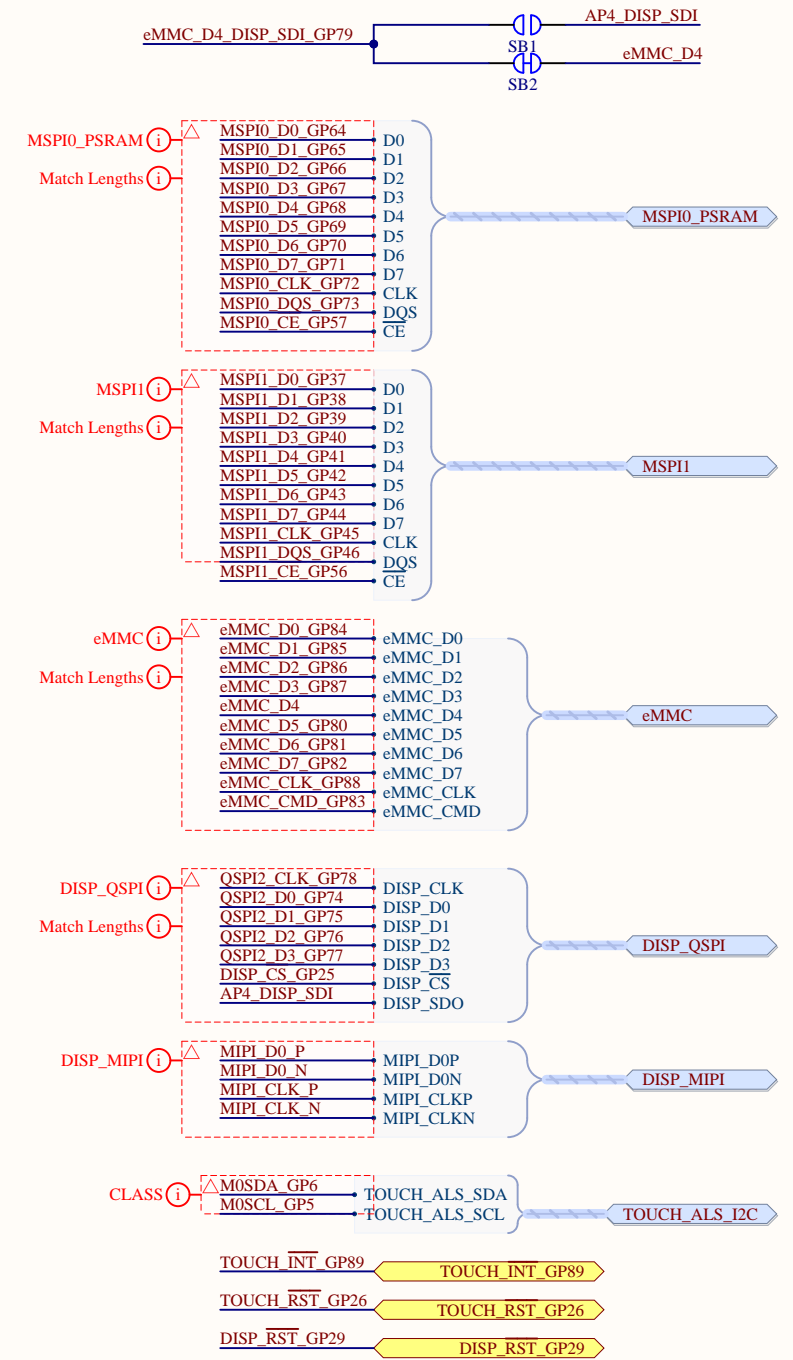



6500 River Place Boulevard
Building 7, Suite 200
Austin, TX 78730
+1 (512) 879-2850

Title: AMAP4PDISP

Size: A	Number: AMSCH-0087	Revision: 1	Sheet 2 of 10
Date: 8/25/2022	Drawn By: Chad Crosby	Aprvd By: Daniel Lanzone	8/25/2022

This document contains information proprietary to Ambiq and shall not be used, reproduced, or disclosed to others, in part or in whole, without express written permission from Ambiq.

EVB Headers

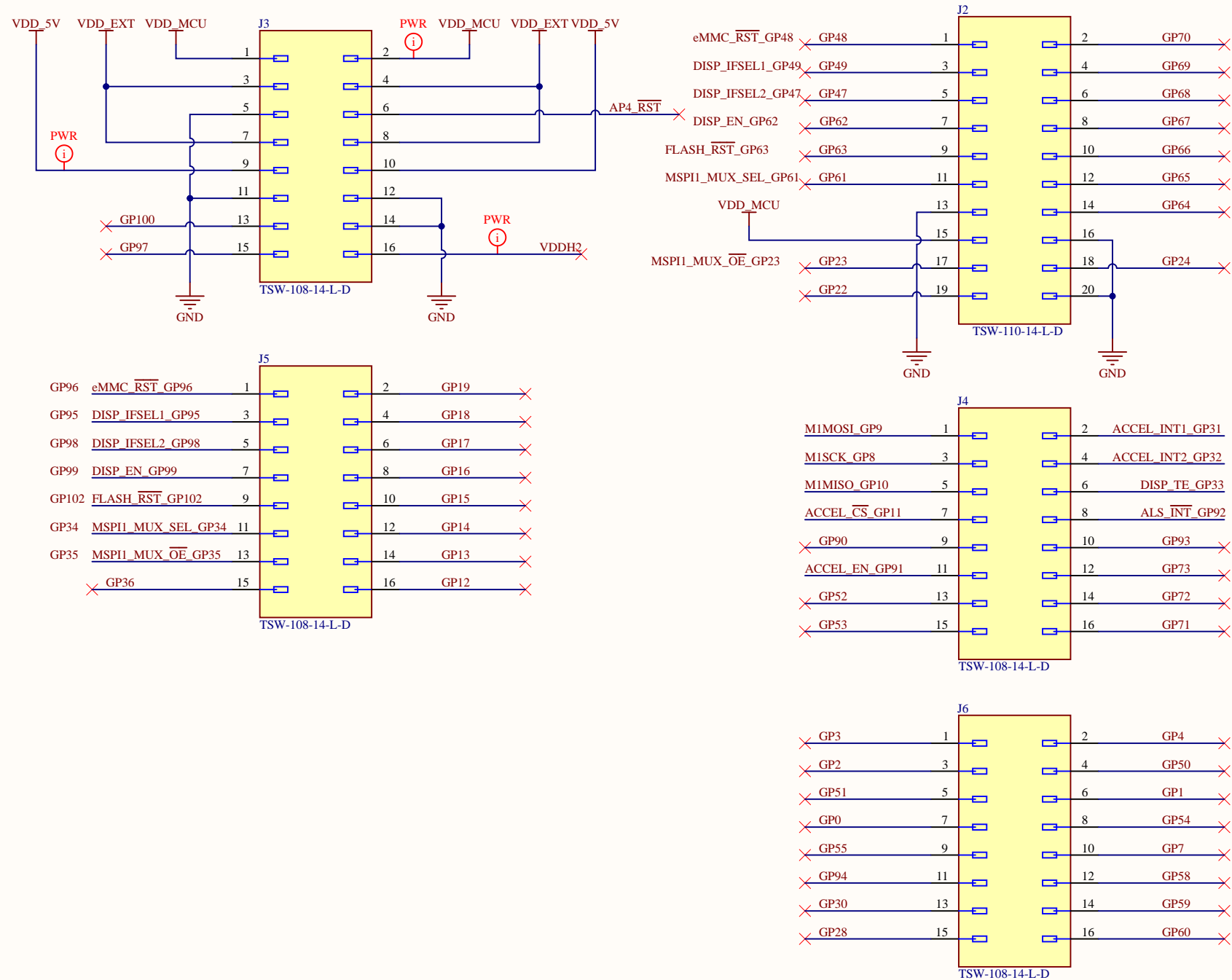

General Display Shield Apollo 4 Signals

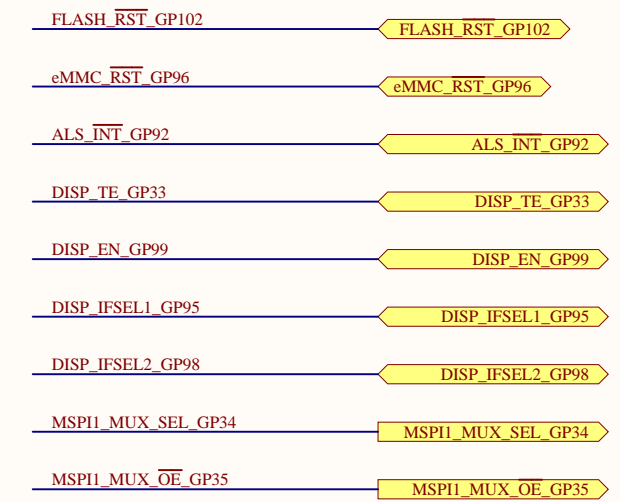

Accelerometer Signals

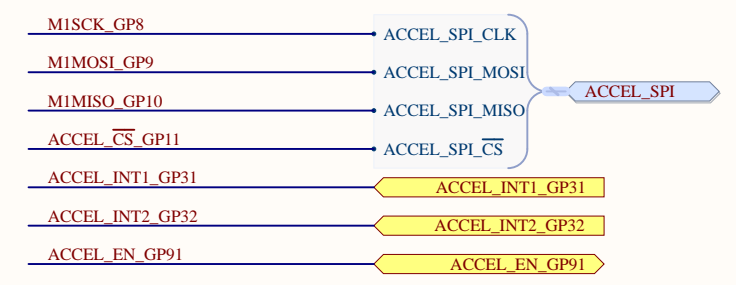



6500 River Place Boulevard
Building 7, Suite 200
Austin, TX 78730
+1 (512) 879-2850

Title: **AMAP4PDISP**

Size: A	Number: AMSCH-0087	Revision: 1	Sheet 3 of 10
Date: 4/26/2022	Drawn By: Chad Crosby	4/26/2022	
	Aprvd By: Daniel Lanzone	11/8/2022	

This document contains information proprietary to Ambiq and shall not be used, reproduced, or disclosed to others, in part or in whole, without express written permission from Ambiq.

PSRAM

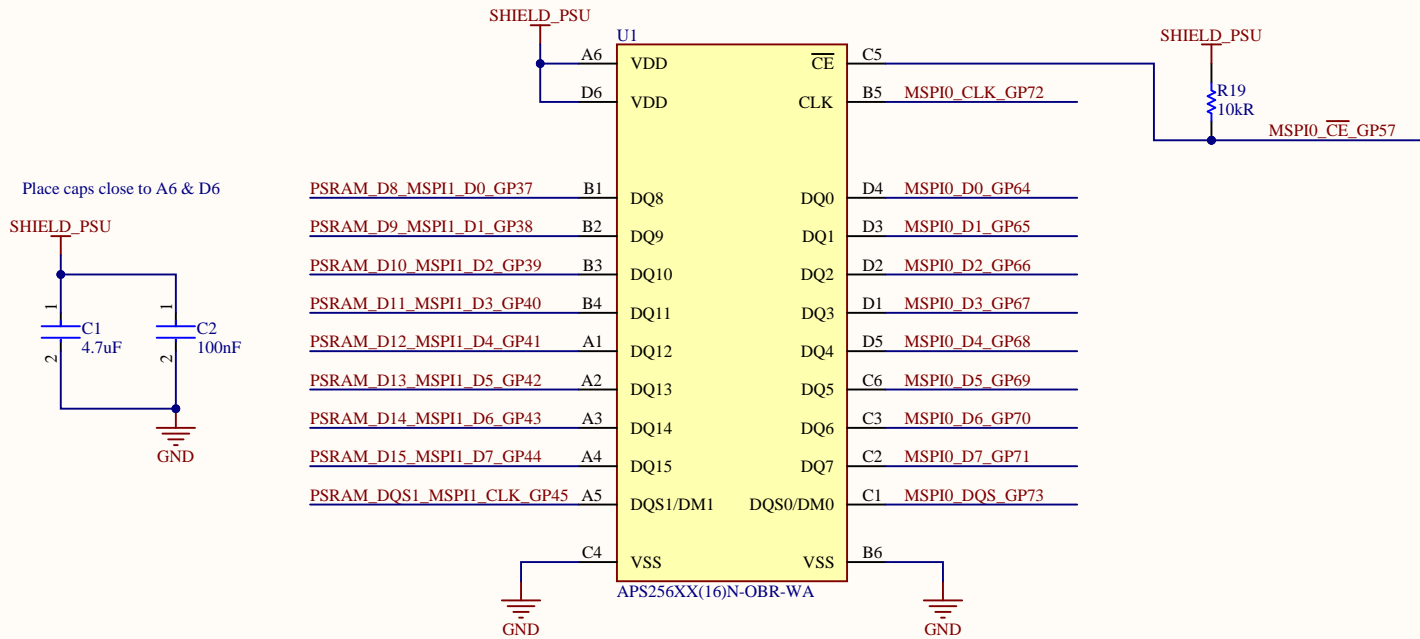

PSRAM MSPI Signals

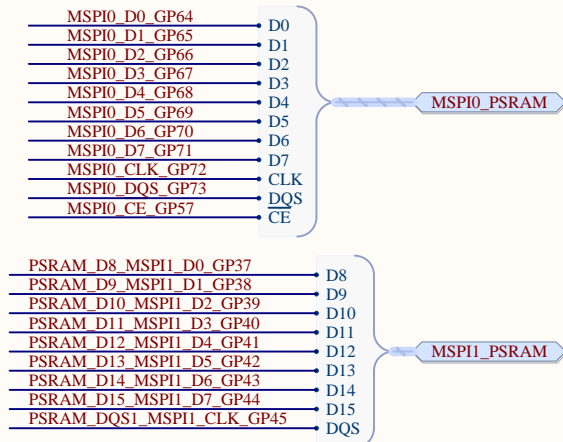

PSRAM MSPI Signal Header

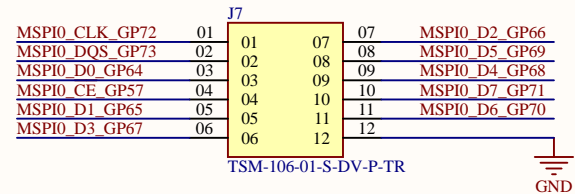



Title
AMAP4PDISP

Size **A** Number **AMSCH-0087** Revision **1** Sheet **4** of **10**

Date **3/7/2022** Drawn By **Chad Crosby** 3/7/2022
 Aprvd By **Daniel Lanzone** 11/8/2022

This document contains information proprietary to Ambiq and shall not be used, reproduced, or disclosed to others, in part or in whole, without express written permission from Ambiq.

6500 River Place Boulevard
 Building 7, Suite 200
 Austin, TX 78730
 +1 (512) 879-2850

NOR Flash

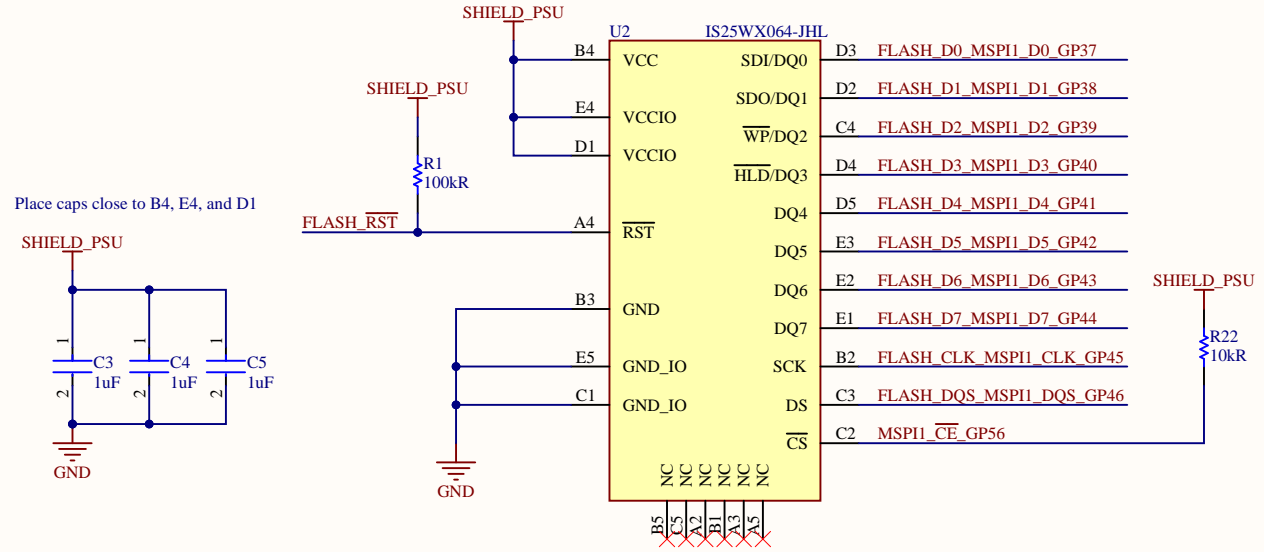

MSPI Flash Signals

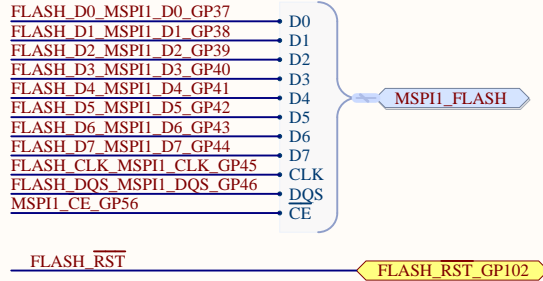

		Title	
		AMAP4PDISP	
Size	Number	Revision	Sheet
A	AMSCH-0087	1	5 of 10
Date	Drawn By	Date	
11/8/2022	Chad Crosby	11/8/2022	
	Aprvd By	Date	
	Daniel Lanzone	11/8/2022	
<small>This document contains information proprietary to Ambiq and shall not be used, reproduced, or disclosed to others, in part or in whole, without express written permission from Ambiq.</small>			

eMMC

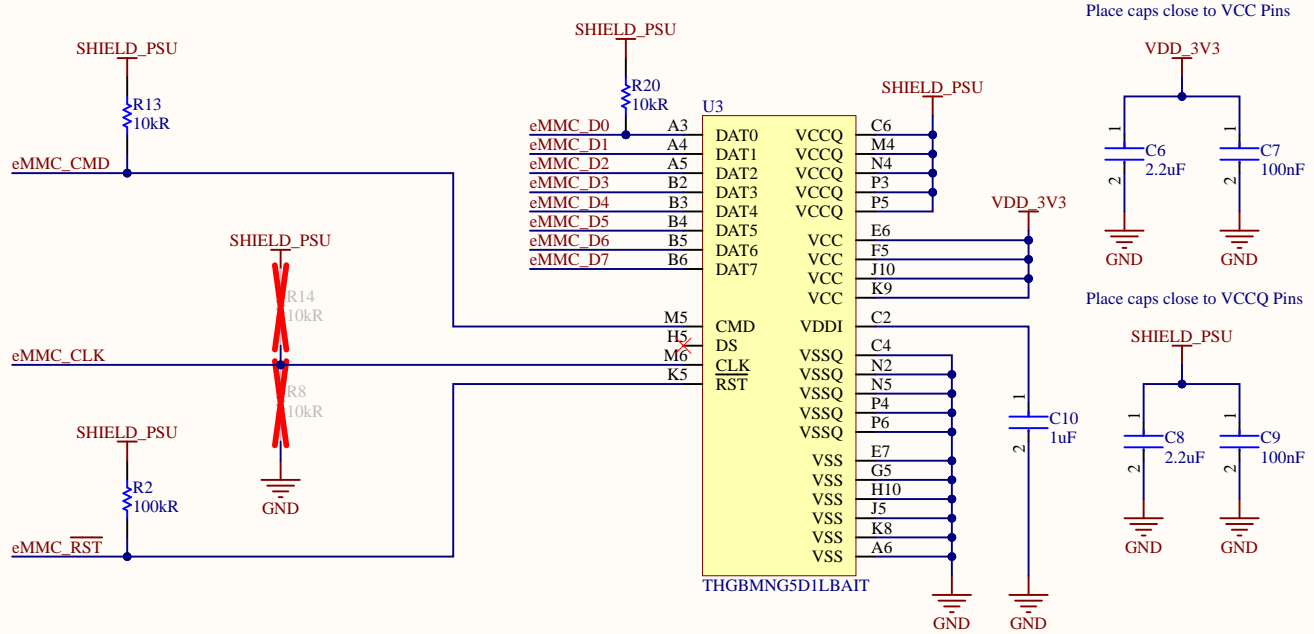

eMMC Signals

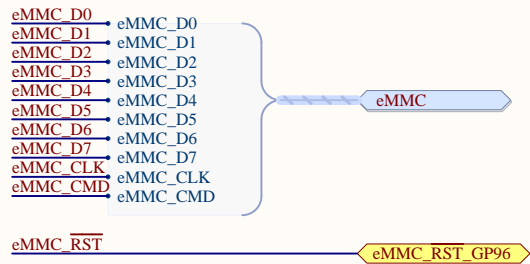

eMMC Signal Header

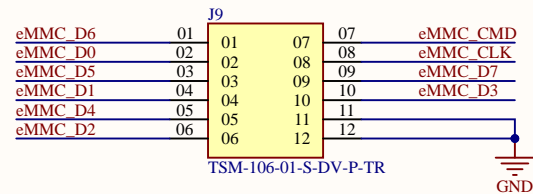



Title
AMAP4PDISP

Size **A** Number **AMSCH-0087** Revision **1** Sheet **6** of **10**

Date **2/25/2022** Drawn By **Chad Crosby** 2/25/2022
 Aprvd By **Daniel Lanzone** 11/8/2022

This document contains information proprietary to Ambiq and shall not be used, reproduced, or disclosed to others, in part or in whole, without express written permission from Ambiq.

6500 River Place Boulevard
 Building 7, Suite 200
 Austin, TX 78730
 +1 (512) 879-2850

Onboard 1.9V Supply

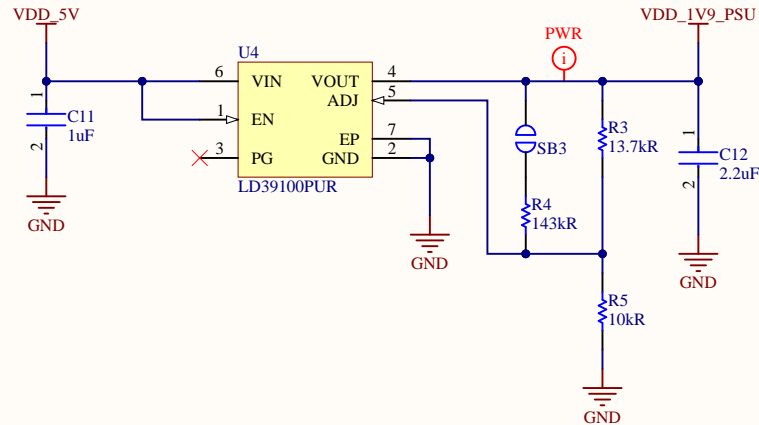

1.9V Supply Option

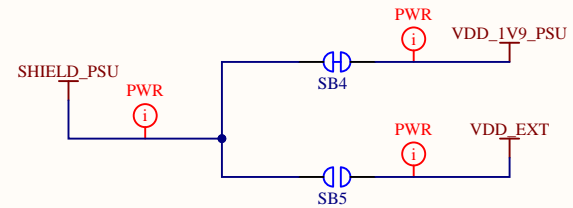

Onboard 3.3V Supply

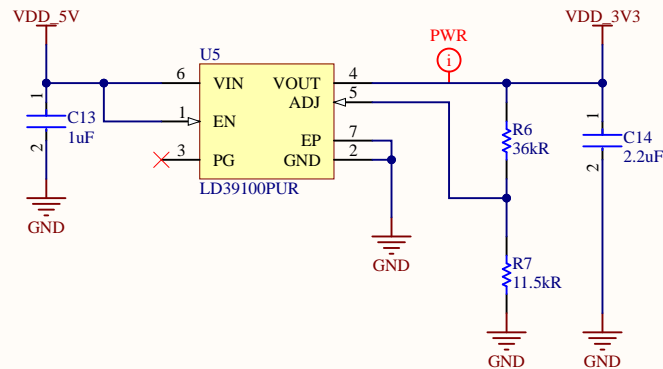

6500 River Place Boulevard
 Building 7, Suite 200
 Austin, TX 78730
 +1 (512) 879-2850

Title
 AMAP4PDISP

Size A	Number AMSCH-0087	Revision 1	Sheet 7 of 10
-----------	----------------------	---------------	---------------

Date 2/18/2022	Drawn By Chad Crosby	2/18/2022
	Aprvd By Daniel Lanzone	11/8/2022

This document contains information proprietary to Ambiq and shall not be used, reproduced, or disclosed to others, in part or in whole, without express written permission from Ambiq.

Display Signal Connector

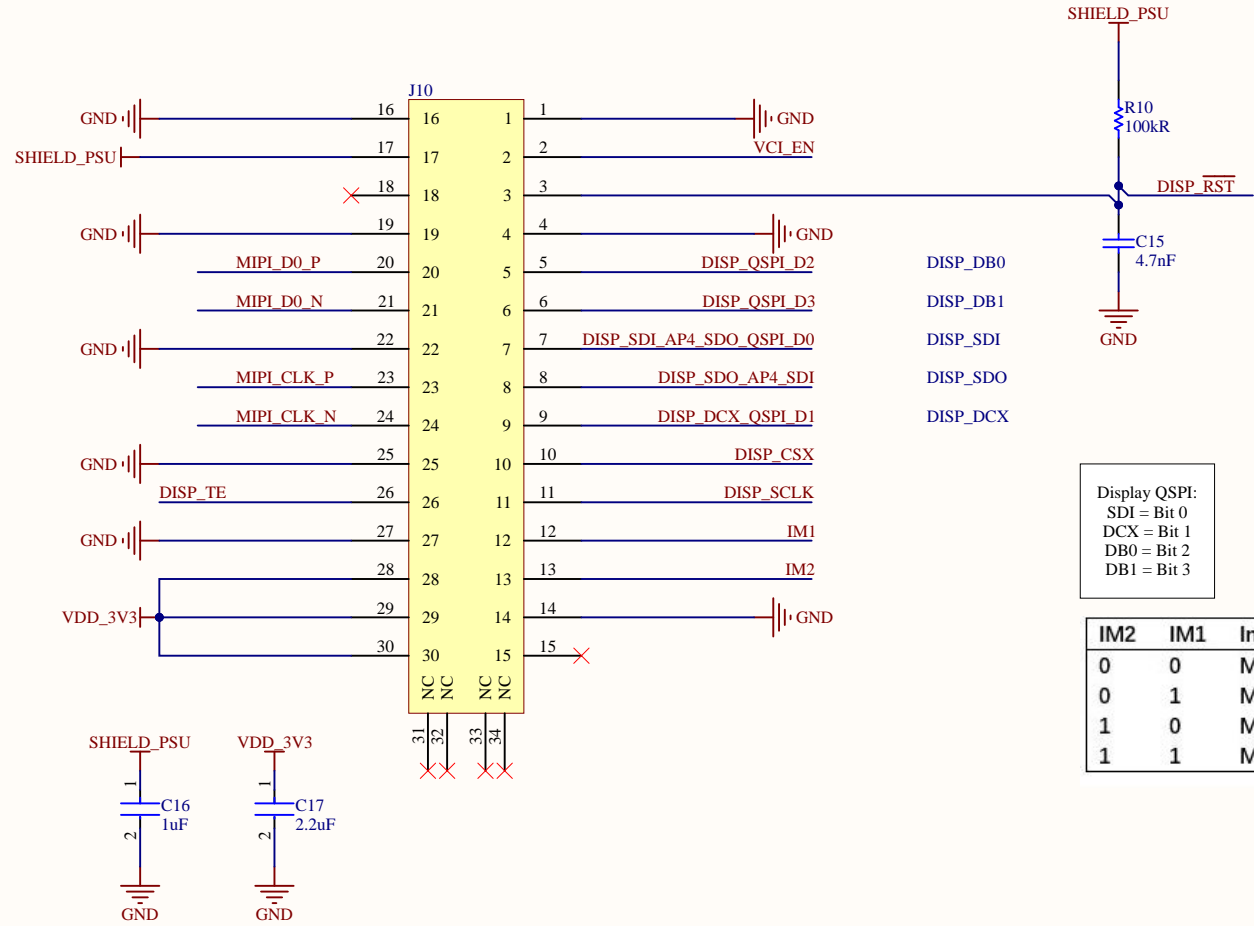

Display QSPI:
SDI = Bit 0
DCX = Bit 1
DB0 = Bit 2
DB1 = Bit 3

IM2	IM1	Interface Mode
0	0	MIPI or 3-wire SPI
0	1	MIPI or 4-wire SPI
1	0	MIPI or QSPI
1	1	MCU 8-bit

Touch & ALS Display Connector

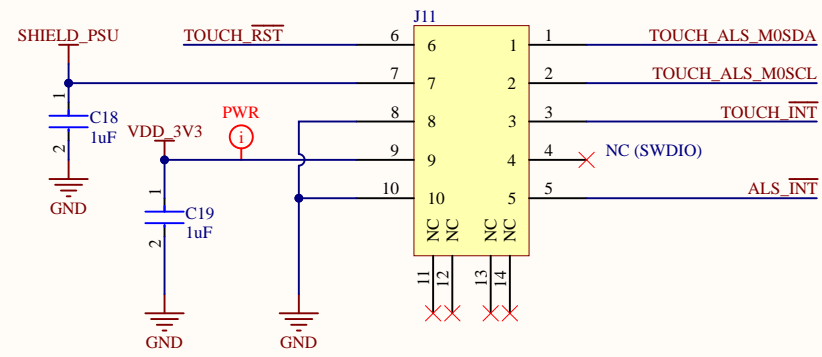

Display Mode Selection & Pull-down Resistors

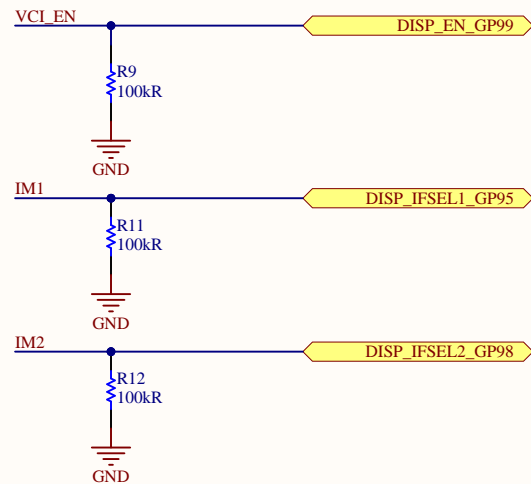

Display, ALS & Touch Signals

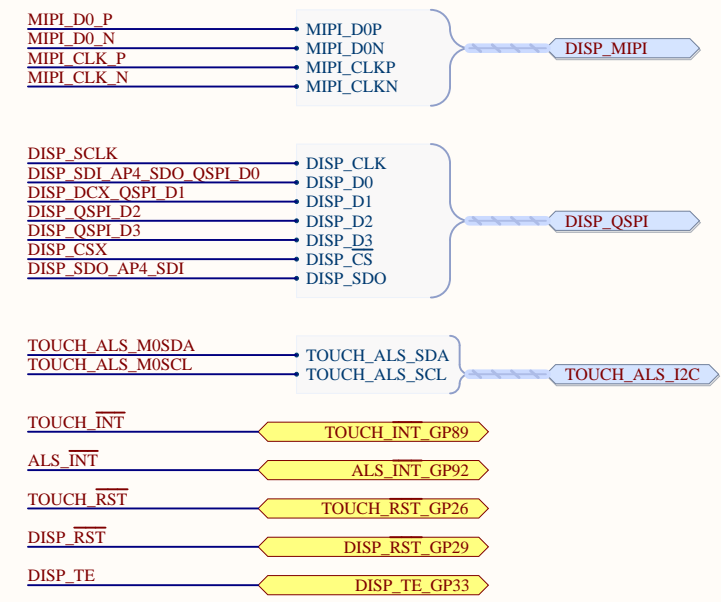

Display Signal Headers

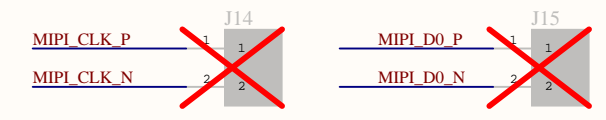
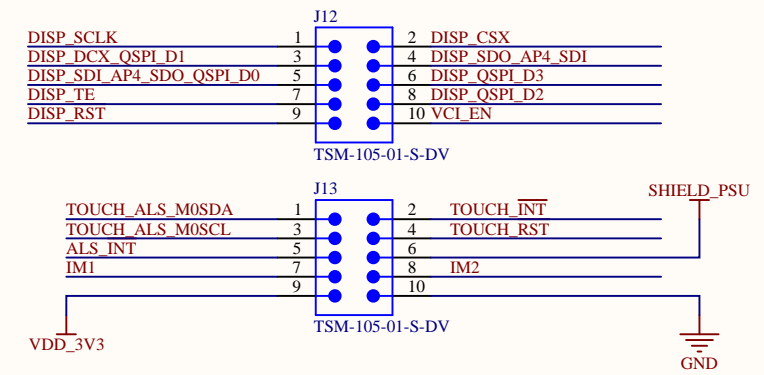

Title: AMAP4PDISP

Size: A Number: AMSCH-0087 Revision: 1 Sheet 8 of 10

Date: 2/25/2022 Drawn By: Chad Crosby 2/25/2022

Aprvd By: Daniel Lanzzone 11/8/2022

6500 River Place Boulevard
Building 7, Suite 200
Austin, TX 78730
+1 (512) 879-2850

This document contains information proprietary to Ambiq and shall not be used, reproduced, or disclosed to others, in part or in whole, without express written permission from Ambiq.

Accelerometer and Loadswitch

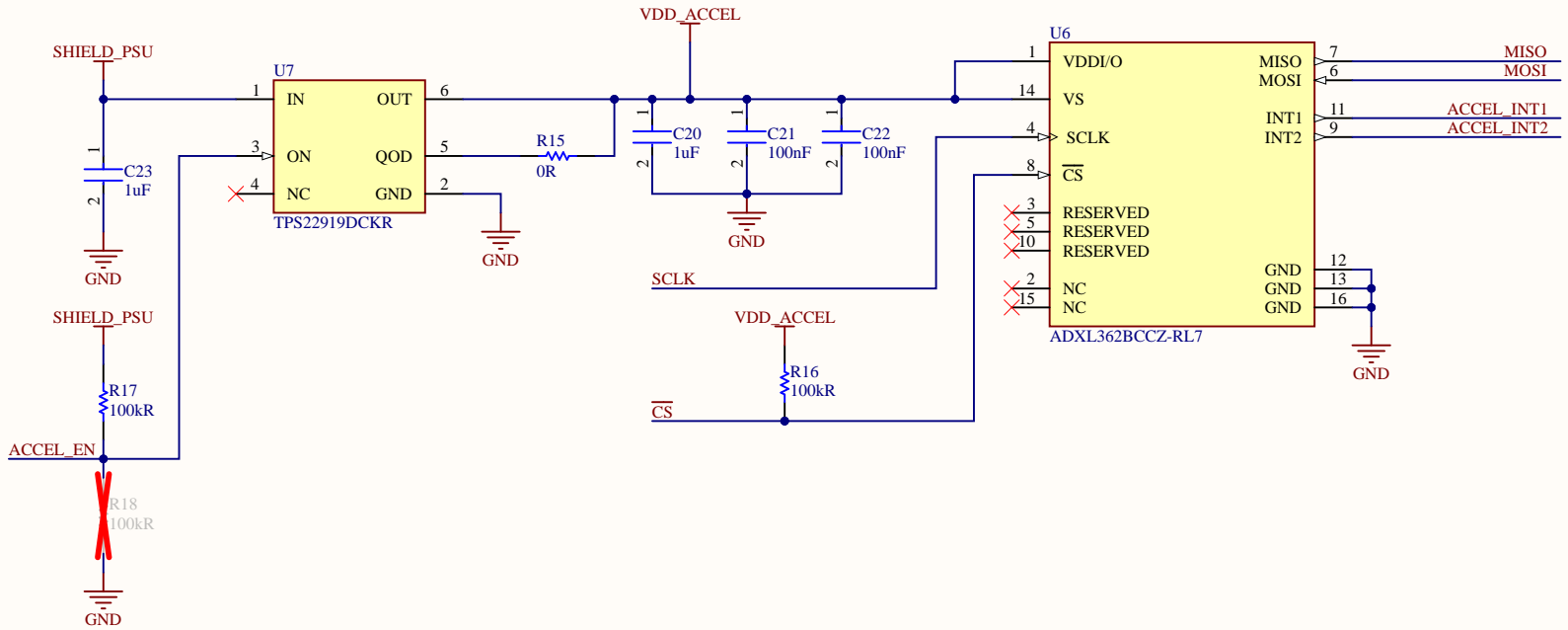

Accelerometer Signals



6500 River Place Boulevard
 Building 7, Suite 200
 Austin, TX 78730
 +1 (512) 879-2850

Title
 AMAP4PDISP

Size A Number AMSCH-0087 Revision 1 Sheet 9 of 10

Date 2/18/2022 Drawn By Chad Crosby 2/18/2022
 Aprvd By Daniel Lanzone 11/8/2022

This document contains information proprietary to Ambiq and shall not be used, reproduced, or disclosed to others, in part or in whole, without express written permission from Ambiq.

